

**ELECTRONIC  
SYSTEMS  
PRODUCTS.**



***ESPRIT***

**MODEL 300/500  
INITIAL INSTALLATION AND  
SET-UP PROCEDURES**

**DEALER MANUAL**

ESPRIT 300/500

INITIAL INSTALLATION AND SET-UP PROCEDURES

( AUTHORIZED ESP DEALERS ONLY )

JUNE 1987

ESP Inc.  
1301 Armstrong Dr.  
Titusville, Fla.  
305-269-6680

## Table of Contents

Chapter 1 INTRODUCTION	6
1.1 FEATURES	6
1.1.1 QUAD STANDARD	6
1.1.2 AUTOLOCK	6
1.1.3 REMOTE CONTROL	6
1.1.4 SELF DIAGNOSTIC	6
1.1.5 CGA/EGA COMPATIBLE	6
1.1.6 RS-232	6
1.2 PHYSICAL CHARACTERISTICS	7
1.2.1 GENERAL	7
1.2.2 16 CHARACTER LCD INDICATORS	7
1.2.3 SWEEP DIRECTION LED INDICATORS	7
Chapter 2 WARNINGS and PRECAUTIONS	8
2.1 X-RADIATION	8
2.2 HIGH VOLTAGE	8
2.3 EXPOSURE TO RAIN OR MOISTURE	8
2.4 PROJECTION TUBES	8
2.5 ELECTRICAL GROUNDING OF EQUIPMENT	9
2.6 CRT PHOSPHOR DAMAGE	9
Chapter 3 LIMITED WARRANTY	10
3.1 WARRANTY PERIOD	10
3.2 DATE OF INSTALLATION	10
3.3 ORIGINAL PURCHASER	10
3.4 WARRANTY SERVICE	10
3.5 SHIPPING	10
3.6 ENVIRONMENTAL DAMAGE	11

3.7 SERIAL NUMBER DEPHACEMENT	11
3.8 MISUSE	11
Chapter 4 INSTALLATION	12
4.1 GENERAL	12
4.2 PHYSICAL SITE CONSIDERATIONS	13
4.2.1 FRONT/REAR PROJECTION	13
4.2.2 CEILING MOUNTING	13
4.3 115 VOLT OR 230 VOLT OPERATION	15
4.4 INFRARED RECEIVER MOUNTING	18
4.5 PROJECTOR TEST	18
4.6 OPTIONAL ACCESSORIES	18
Chapter 5 SPECIFICATIONS	21
5.1 ESPRIT 300 specifications	21
5.2 ESPRIT 500 specifications	22
Chapter 6 OPERATION	23
6.1 GENERAL	23
6.2 REMOTE CONTROL DESCRIPTION	23
6.3 BACK PANEL DESCRIPTION	23
6.4 INPUT SIGNALS	23
6.4.1 COMPOSITE VIDEO INPUTS	23
6.4.2 RGB INPUTS	24
6.4.2.1 ANALOG RGB	24
6.4.2.2 TTL RGB	24
6.5 SYSTEM OPERATION	25
6.5.1 SYSTEM TURN-ON	25
6.5.2 IMAGE QUALITY CHECK	25
6.5.3 SIGNAL SOURCE SELECTION	26

6.5.4 PHASE ADJUSTMENT-SINGLE PROJECTOR MODE	26
6.5.5 IMAGE QUALITY ADJUSTMENTS	26
6.5.6 STANDBY	27
6.5.7 TEST PATTERN	27
6.5.8 RASTER ALIGNMENT ADJUSTMENTS	27
6.5.9 VOLUME AND MUTE	28
6.5.10 MULTIPLE PROJECTOR MODE (ESPRIT 500 ONLY)	28
6.5.11 PROJECTOR NUMBER (MULTIPLE PROJECTOR MODE)	28
Chapter 7 CHANGING PROJECTOR PARAMETERS	29
7.1 CHANGING PICTURE SIZE	29
7.2 CHANGING DEFLECTION ANGLE	29
7.3 REAR SCREEN PROJECTION	29
7.4 REGISTRATION PROCEDURE	31
7.4.1 MECHANICAL	31
7.4.1.1 LENS FOCUS	31
7.4.1.2 LATERAL LENS ADJUSTMENT	33
7.4.2 ELECTRICAL	33
7.4.2.1 MASTER (GREEN) IMAGE ADJUSTMENT	33
7.4.2.2 RED IMAGE ADJUSTMENT	37
7.4.2.3 BLUE IMAGE ADJUSTMENT	39
7.5 SWEEP REVERSAL PROCEDURES	40
7.5.1 HORIZONTAL SWEEP REVERSAL PROCEDURE	40
7.5.2 VERTICAL SWEEP REVERSAL PROCEDURE	40
7.6 BLANKING PROCEDURES	41
7.6.1 NTSC TOP AND BOTTOM BLANKING PROCEDURE	42
7.6.2 RGB TOP AND BOTTOM BLANKING PROCEDURE	42

7.6.3 PAL/SECAM TOP AND BOTTOM BLANKING PROCEDURE	42
7.6.4 LEFT AND RIGHT SIDE BLANKING PROCEDURE	43
7.7 BLUE ENHANCE ADJUSTMENT PROCEDURE	43
7.8 ELECTRONIC FOCUS ADJUSTMENT PROCEDURE	43
7.9 MASTER HORIZONTAL KEYSTONE ADJUSTMENT PROCEDURE	43
7.10 MASTER EAST/WEST PINCUSHION ADJUSTMENT PROCEDURE	44
7.11 RASTER SIZING/CENTERING PROCEDURE	44
7.12 HORIZONTAL LINEARITY ADJUSTMENT PROCEDURE	46
7.13 VERTICAL LINEARITY ADJUSTMENT PROCEDURES	48
Chapter 8 SYSTEM TROUBLESHOOTING	50
8.1 PREVENTATIVE MAINTENANCE	50
8.2 SYSTEM TROUBLESHOOTING	50
8.2.1 SYSTEM WILL NOT OPERATE	50
8.3 EXCHANGE POLICY	51
Chapter 9 DIAGNOSTICS	52
9.1 GENERAL	52
9.2 DIAGNOSTIC MESSAGES	52
9.3 EARLY PRODUCTION ESPRIT 500 DIAGNOSTICS	52
Chapter 10 RS-232 INTERFACE DATA	54
10.1 GENERAL	54
GLOSSARY	55
CREDITS	56

## Chapter 1

### INTRODUCTION

The ESPRIT Series of video projectors have, as standard equipment, many functions not found in even the most expensive projectors. Two of the projectors may be upgraded to the next model, as the result of a modular design concept, so that your projection system can grow with your requirements. Some of the innovations offered by the ESPRIT 300 and ESPRIT 500 are:

#### 1.1 FEATURES

##### 1.1.1 QUAD STANDARD

A built-in capability which automatically senses and decodes which of the four international standards of video information is being applied to the composite video input. The auto select capability can be manually over-ridden if desired.

##### 1.1.2 AUTOLOCK

The ability to automatically lock the horizontal and vertical circuits to the input sync signals. This capability is invaluable in any system where more than one signal will be utilized.

##### 1.1.3 REMOTE CONTROL

The Remote Control is extremely user friendly, and is standard equipment on all ESPRIT projectors. The microprocessor used in the projector allows a vast array of information to be controlled by the remote control with simple, one-function, color-coded buttons. The Remote control is available in two versions, wired and infrared.

##### 1.1.4 SELF DIAGNOSTIC

The ESPRIT 300 constantly monitors all major voltages and signals and indicates the status on 16 internal LED indicators.

The ESPRIT 500 constantly monitors all major voltages and signals and gives a plain English operational status on a large 16 character external LCD display.

##### 1.1.5 CGA/EGA COMPATIBLE (ESPRIT 500 only)

On the back of the projector is a standard nine pin "D" connector for input from an IBM PC (or compatible). The projector will automatically configure itself to accept either CGA input or EGA input.

##### 1.1.6 RS-232 (ESPRIT 500 only)

The ESPRIT projectors are the only projectors with full

duplex RS-232 communications and networking capability. The projectors can be controlled from a remote computer or modem using RS-232 and MOTOROLA S1 format. Projectors can be looped through so that multiple projectors can be addressed and controlled by one central source.

## 1.2 PHYSICAL CHARACTERISTICS

### 1.2.1 GENERAL

The ESPRIT projector is a small, light, state of the art unit which is designed to blend with the decor where it is utilized. The projector has a built-in mechanical 7° lens offset to facilitate mounting close to the ceiling.

### 1.2.2 16 CHARACTER LCD DISPLAY

The ESPRIT 500 has a large, LCD display which gives the operating and diagnostics status of the unit at a glance even if it is ceiling mounted.

### 1.2.3 SWEEP DIRECTION LED INDICATORS

Two sweep direction indicators tell you at a glance whether horizontal and vertical sweeps are normal or reversed by the color of their respective indicators.



## Chapter 2

### WARNINGS and PRECAUTIONS

#### 2.1 X-RADIATION

During the operation of any solid state video projection system the picture tube is a primary source of x-radiation. The projection tubes used in ESPRIT projectors have leaded glass to safeguard the leakage of x-rays. It complies with all U.S. Department of Health and Human Services rules governing the emission of x-radiation. FOR CONTINUED X-RADIATION PROTECTION, THE USER SHOULD NEVER ATTEMPT TO REPLACE THE PROJECTION TUBES OR OTHER ELECTRONIC COMPONENTS. Instead, all service to the system should be performed by a qualified service technician.

#### 2.2 HIGH VOLTAGE

The projector system contains HIGH VOLTAGE derived from supplies capable of delivering LETHAL quantities of energy. To avoid serious personal injury, only a qualified technician should service and adjust internal modules of the projection unit. There are no user serviceable parts within the ESPRIT projector. ALL INTERNAL SERVICING MUST BE PERFORMED BY A QUALIFIED TECHNICIAN.

#### 2.3 EXPOSURE TO RAIN OR MOISTURE

TO REDUCE FIRE OR SHOCK HAZARD, NEVER EXPOSE THE PROJECTOR TO RAIN OR MOISTURE. If this happens inadvertently, do not use the system until it has been inspected and/or serviced by a qualified technician.

#### 2.4 PROJECTION TUBES

The projection tubes inside the Projection Unit enclose a high vacuum. Care must be taken to insure that the projector is not dropped or otherwise subjected to violent blows.

#### WARNING

ATTEMPTS TO ALTER THE FACTORY SET INTERNAL CONTROLS OR TO CHANGE OTHER SETTINGS NOT SPECIFICALLY DISCUSSED IN THIS MANUAL CAN LEAD TO PERMANENT DAMAGE TO THE PROJECTOR AND VOID THE WARRANTY.

## 2.5 ELECTRICAL GROUNDING OF EQUIPMENT

The ESPRIT projectors are manufactured with a standard three wire power cord to insure proper grounding. To insure that the chassis and exposed metal portions of your projection system have proper grounding, always plug the unit into a standard three wire outlet. If any doubt exists about the outlet, contact an electrician to check the outlet.

## 2.6 CRT PHOSPHOR DAMAGE

The phosphor material, coated on the face of the CRT, has a given life. Under normal usage, the phosphor will degenerate at the same rate throughout the coating. If a high intensity fixed pattern is projected by the CRT for long periods, a fixed pattern will be etched into the phosphor. The amount of etching is determined by the intensity and the time duration the fixed pattern is projected. Using fixed patterns at high intensity is not recommended. Since the test pattern is a fixed pattern, it should be used only at low intensity and for short periods of time.

## Chapter 3

### LIMITED WARRANTY

Electronics Systems Products, Inc. ("ESP") warrants this product to be free from defects in material and workmanship, under normal use, subject to the limitations provided below.

#### 3.1 WARRANTY PERIOD.

For the first twelve (12) months after the date of installation, ESP will repair or replace any defective part without charge for labor or parts. Replacement parts will be covered by this Limited Warranty for the remainder of the warranty period. This Limited Warranty applies only to parts supplied or designed by ESP.

#### 3.2 DATE OF INSTALLATION.

To establish the date of installation, the ESP Certificate of Registration should be completed, signed and returned to Electronics Systems Products, Inc., postmarked no later than thirty (30) days from the date of installation. If the ESP Certificate of Registration is not returned within such time, ESP will use the date that the unit was shipped from the factory as the date of installation.

#### 3.3 ORIGINAL PURCHASER.

This Limited Warranty is limited to the original purchaser (end-user) of this product from either ESP or ESP's authorized dealer, distributor or authorized agent.

#### 3.4 WARRANTY SERVICE

For servicing under this Limited Warranty, this product must be presented to ESP, an authorized ESP service center or the authorized ESP selling dealer.

#### 3.5 SHIPPING

Prior to shipping this product or any subassembly to ESP, a Return Authorization Number must be obtained from the ESP Service Department. This product must be shipped in the manufacturer's original shipping carton or other ESP approved packaging. All freight and shipping charges to ESP must be prepaid by the purchaser. Damage resulting from abuse in shipment of this product is not covered by this Limited Warranty. ESP approved shipping cartons are available from ESP at a nominal charge.

### 3.6 ENVIRONMENTAL DAMAGE

This Limited Warranty does not cover damage or repairs that are necessary due to floods, winds, fires, lightning, accidents, corrosive atmosphere, excessive exposure to water (moisture) or heat, or any other conditions beyond the control of ESP.

### 3.7 SERIAL NUMBER DEFACEMENT

This Limited Warranty is void for this product if the serial number has been changed, removed or defaced.

### 3.8 MISUSE

This Limited Warranty does not cover repairs that are necessary due to:

1. incorrect installation;
2. voltage conditions, blown fuses, open circuit breakers or any other inadequacy or interruption of electrical service.
3. misapplication, abuse, improper servicing, or any other improper operation, including misadjustment of any control.
4. defects in or caused by associated equipment; or
5. repair and/or modification of a subassembly performed by other than ESP factory personnel.

Normal maintenance as outlined in the installation and servicing instructions or owner's manual will be the responsibility of the purchaser.

ESP MAKES NO WARRANTY OF ANY KIND, EXPRESS OR IMPLIED, IN CONNECTION WITH THIS PRODUCT EXCEPT AS HEREINABOVE PROVIDED. IMPLIED WARRANTIES OF MERCHANTABILITY OR FITNESS FOR A PARTICULAR PURPOSE OR ARISING FROM A COURSE OF DEALING OR USAGE OF TRADE ARE SPECIFICALLY EXCLUDED. SHOULD THIS PRODUCT PROVE TO BE DEFECTIVE IN MATERIAL OR WORKMANSHIP, THE PURCHASER'S SOLE REMEDY SHALL BE SUCH REPAIR OR REPLACEMENT AS HEREINABOVE EXPRESSLY PROVIDED AND UNDER NO CIRCUMSTANCES SHALL ESP BE LIABLE FOR ANY LOSS, OR DAMAGE, DIRECT, INCIDENTAL OR CONSEQUENTIAL, INCLUDING LOSS OF PROFITS OR BUSINESS OPPORTUNITIES, RESULTING FROM DEALER OR DISTRIBUTOR INSTALLATION OR SERVICES. Some states do not allow the exclusion of incidental or consequential damages, so the above limitation may not apply to you. This Limited Warranty gives you specific legal rights, and you may also have other rights which may vary from state to state. No other person is authorized to assume for ESP any additional obligations beyond those provided herein.

## Chapter 4

### INSTALLATION

#### 4.1 GENERAL

The ESPRIT projector is factory preset to project a 60" X 80" image at a throw distance of approximately 10 feet. The unit is also adjusted for table mounted projection (mounted on flat table 7" below the center line of screen).

There will, of course, be many applications that will not fit this standard. Chapter 7 provides information on how to change the configuration for your particular needs.

The selling dealer, or his authorized representative, will provide the initial set-up and registration upon installation of this projector. Discuss any deviation from the factory preset conditions with your dealer, prior to the actual installation, to determine the feasibility of the deviation.

Any questions concerning the installation or operation of the ESPRIT projector, not covered in the manual, should be directed toward your authorized ESP Service Representative or the ESP Technical Services Department.

After the set-up and registration is completed, fill out the Certificate of Registration and the dealer preparation questionnaire and mail them to the factory in the preaddressed, postage paid envelope.

#### SAFETY PRECAUTION

THE POWER CORD SUPPLIED WITH THE PROJECTOR IS A STANDARD THREE WIRE POWER CORD. FOR YOUR SAFETY, THE POWER CORD PLUG MUST BE CONNECTED TO A PROPERLY WIRED AND GROUNDED OUTLET. AN IMPROPERLY WIRED OUTLET CAN PLACE HAZARDOUS VOLTAGES ON ACCESSIBLE METAL PARTS OF THE PROJECTOR CHASSIS AND VOIDS THE WARRANTY DUE TO POTENTIAL DAMAGE TO THE UNIT.

In ceiling mounted application, it is very important that the bracket be safely attached to the support unit, i.e., ceiling support beam. The installation of the mounting bracket should be supervised by, if it is not installed by your ESP Authorized Dealer.

#### NOTE

ELECTRONIC SYSTEMS PRODUCTS INC. IS NOT RESPONSIBLE FOR INJURY OR DAMAGE CAUSED BY AN IMPROPERLY INSTALLED PROJECTION UNIT.

#### NOTE:

ALL UNITS LEAVE THE FACTORY CONFIGURED FOR 115 VOLT OPERATION. MOST OVERSEAS UNITS NEED TO BE CONFIGURED FOR 230 VOLT OPERATION. TO CHANGE CONFIGURATION REFER TO PARAGRAPH 4.3.

## 4.2 PHYSICAL SITE CONSIDERATIONS

The optimum installation would be with the projector table mounted and in a dark room. Since these parameters can not meet the requirements of most applications, compromises must be made. In order to make the best compromises, several alternatives should be considered.

### 4.2.1 FRONT/REAR PROJECTION

Front projection provides the brightest image, but the screen is more sensitive to ambient light. High image light gain can easily be obtained from front screens but at the same time the viewing angle is reduced. The projector should be mounted in such a way as to minimize interference with the viewing audience.

Rear projection eliminates projector interference with the viewing audience but requires a large area behind the screen. With rear projection, higher ambient light in the viewing area is allowable but there is some inherent reduction in image brightness.

On-axis rear screen projection requires the horizontal image being in the reversed mode (LED glows red).

Rear screen projection using mirrors will vary, determined by the particular installation configuration.

To reverse either horizontal or vertical deflection, refer to Chapter 7 Paragraph 7.5.

### 4.2.2 CEILING MOUNTING

Ceiling mounting the projector moves the unit out of the viewing path of the audience but will result in some top and bottom defocusing of the projected image. The projection room size and hot spots can be reduced somewhat by ceiling mounting in rear mounted applications. When the ESPRIT projector is ceiling mounted it will be inverted from the table or floor mounting. This inversion requires that the horizontal and the vertical sweeps be reversed. You can tell at a glance whether the sweeps are set up for normal or inverted operation by the color of the sweep direction LED's. Both LED's should glow green for front projection floor or table mounting and both LED's should glow red for front projection ceiling mounting.

Ceiling mounted rear screen projection requires the vertical sweep being in the reverse mode (LED glows red).

To reverse the sweep refer to Chapter 7 paragraph 7.5.

The Esprit logo on the side of the projector may be inverted by pulling it out, rotating it, and allowing it to retract. This allows the logo to read correctly mounted in either position.

To mount the bracket assembly on the projector follow the steps listed below. (Refer to Figure 1)

1. Turn the projector over so that the leveling feet (5) are pointed upward.

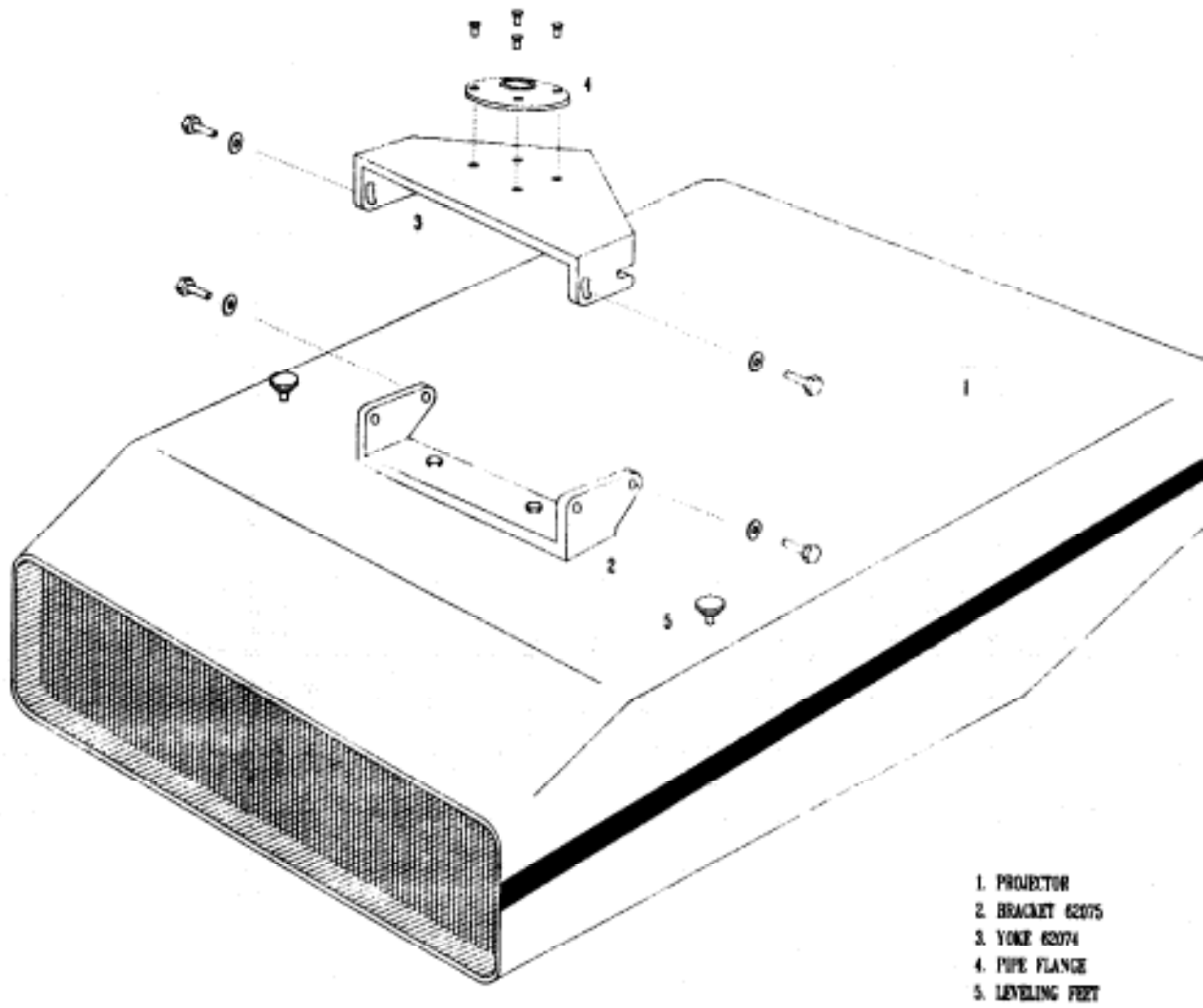

- 1. PROJECTOR
- 2. BRACKET 62075
- 3. YOKE 62074
- 4. PIPE FLANGE
- 5. LEVELING FEET

FIGURE 1

2. Remove the two leveling feet.
3. Attach the ceiling bracket (2) to the projector using two 5/16x18x1" bolts. (insure that the protruding portion of the bracket is pointed towards the rear of the unit)
4. Mount the pipe flange (4) to the yoke (3) with the four 1/4x20x3/4" flat head screws, four 1/4" split lock washers, and four 1/4x20 hex nuts. Secure this assembly to a two inch pipe, as required for the installation.
5. Start (at least four turns) two 5/16x18x1" bolts, with 5/16 lock washers, into the bracket as shown in Figure 1.
6. Lift the projector up and slide the two bolts that have been started into the slots in the yoke assembly (3).
7. Tighten the bolts a few more turns, then start the last two bolts, with lock washers, in the remaining slots of the yoke assembly.
8. Tighten the bolts finger tight.
9. When the image is projected, you will be able to move the image up and down by moving the unit in the slots.
10. When the projector is in the desired position, tighten all four remaining bolts.

#### 4.3 115 VOLT OR 230 VOLT OPERATION

All ESPRIT projectors are shipped from the factory configured for 115 Volt 60 Hz operation. To change the projector so that you can apply a different source, perform the following:

- A. Remove the power cord from the back of the projector.
- B. Open the door above the power plug to access the fuse and voltage select barrel.
- C. The voltage select barrel will indicate the present voltage selected. If it is not the desired voltage, pull the barrel straight out, rotate it and plug it back in so that it reads the correct voltage.
- D. Replace the fuse with the proper size for the voltage selected. (5 Amp Slow blow for 115V and 3.15 Amp Slow blow for 230V, Ensure arrows are lined up)
- E. Close the door and replace the power plug with the proper plug for the electrical standard of that country.
- F. Plug the power cord back in to the rear of the projector.



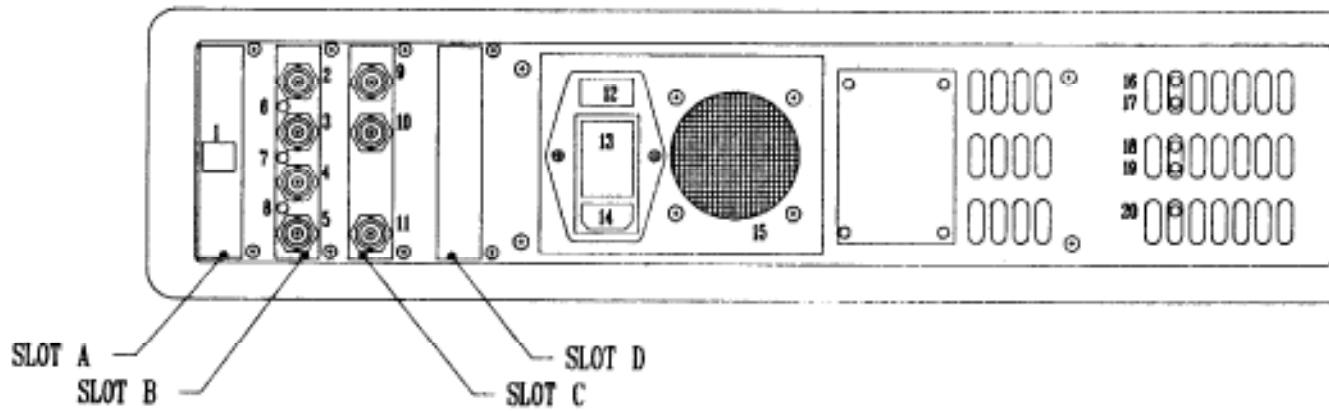

### 300 REAR PANEL

- |                                    |  |   |   |   |
|------------------------------------|--|---|---|---|
| <b>SLOT A</b><br>REMOTE CONTROL BD | <b>SLOT B</b><br>RGB INPUT BD  | <b>SLOT C</b><br>QUAD-STANDARD<br>VIDEO BD  | <b>SLOT D</b><br>BLANK<br>AUDIO(OPTIONAL) | <b>OTHER</b>  |
| 1. REMOTE CONNECTOR                | 2. RED<br>3. GREEN<br>4. BLUE<br>5. SYNC<br>6. RED SUB-CONTRAST<br>7. GREEN SUB-CONTRAST<br>8. BLUE SUB-CONTRAST | 9. VIDEO<br>10. LOOP THRU<br>11. VERT DRIVE |   | 12. ON/OFF SWITCH<br>13. FUSE/VOLT SELECT<br>14. LINE CORD<br>15. FAN<br>16. RED VERT SIZE<br>17. BLUE VERT SIZE<br>18. MASTER VERT SIZE<br>19. VERT LIN<br>20. VERT CENTER |

FIGURE 2

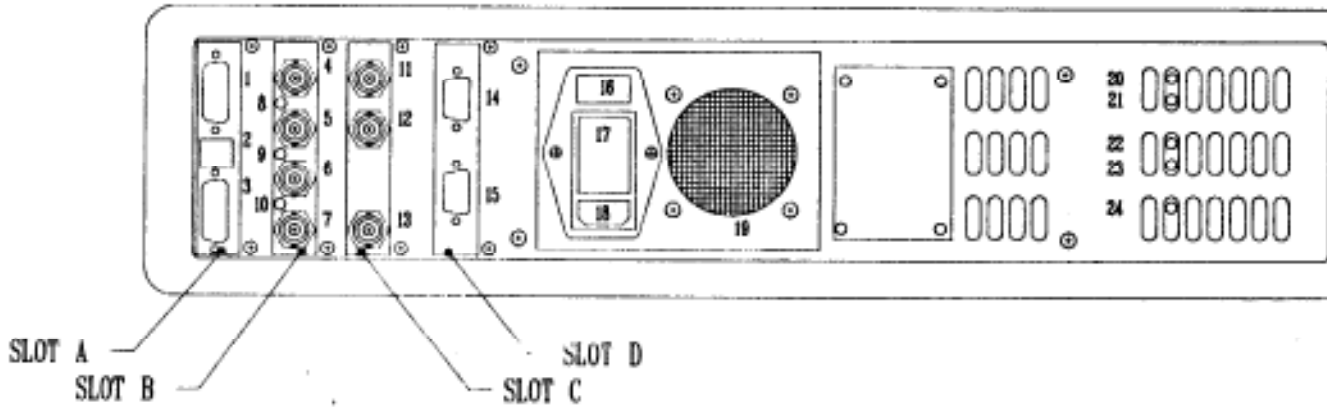

### 500 REAR PANEL

- |  |  |   |   |   |
|--|--|---|---|---|
| <p><b>SLOT A</b><br/>REMOTE CONTROL BD</p> <p>1. RS232 HOST<br/>2. REMOTE CONNECTOR<br/>3. RS232 SLAVE</p> | <p><b>SLOT B</b><br/>RGB INPUT BD</p> <p>4. RED<br/>5. GREEN<br/>6. BLUE<br/>7. SYNC<br/>8. RED SUB-CONTRAST<br/>9. GREEN SUB-CONTRAST<br/>10. BLUE SUB-CONTRAST</p> | <p><b>SLOT C</b><br/>QUAD-STANDARD<br/>VIDEO BD</p> <p>11. VIDEO<br/>12. VIDEO LOOP THRU<br/>13. VERT DRIVE</p> | <p><b>SLOT D</b><br/>TTL BD</p> <p>14. TTL IN<br/>15. TTL LOOP THRU</p> | <p><b>OTHER</b></p> <p>16. ON/OFF SWITCH<br/>17. FUSE/VOLTS<br/>18. LINE CORD<br/>19. FAN<br/>20. RED VERT<br/>21. BLUE VERT<br/>22. MASTER VERT<br/>23. VERT LIN<br/>24. VERT CENT</p> |
|--|--|---|---|---|

FIGURE 3

#### 4.4 INFRARED RECEIVER MOUNTING

The standard cable for the Infrared receiver is 6 ft. in length. Longer cables are available from E.S.P. if you desire to mount the receiver in a position further than 6 ft. from the projector. The cables are available in lengths up to 100 ft. in 25 ft. increments. For most rear screen applications the receiver may be mounted on the projector side of the screen. The distance from the remote control to the receiver should not exceed 50 ft.

#### 4.5 PROJECTOR TEST

After double checking to insure the projector is properly mounted, the Infrared Receiver is correctly connected (if used), and the correct voltage is supplied to the projector, you are ready to energize the projector (Refer to Figure 2 or 3).

There is a main power rocker switch on the rear panel, just above the power cord. When this switch is OFF a red "O" can be observed. Turn the switch to the ON position. When this switch is turned ON the LCD display should display the message "ESP MODEL 300" or "ESP MODEL 500" as the case may be.

(Refer to Figure 4) The next step is to depress the green ON/OFF button (10) on the Remote Control. When this button is depressed, a sequence of events should occur.

The red LED above the fan on the rear panel should light up, the fan should start running, and LCD display will give the message "STATUS OK" and then display the mode of operation that the projector was using when it was de-energized.

If the above events occur as listed, proceed to Chapter 7 to perform the necessary procedures for your application.

If for some reason the events do not occur as listed above, proceed to Chapter 8, Section 8.2 for aid in determining your problem.

#### 4.6 OPTIONAL ACCESSORIES

REMOTE CONTROL EXTENSIONS - Comes in 25 foot increments up to 100 feet.

OPTICAL WEDGES - To reduce the effects of shading on images smaller than 6 feet in width. (For acrylic lenses only)

WIDE SCREEN LENSES - These lenses provide a means of projecting an image up to 25 feet in width. They are f/1.0 lenses with 130 mm focal length and a resolution of 3 line pairs per mm throughout field.

PORTABLE FLOOR STAND - A five leg stand with heavy duty castors for installations where portability is required.

## REMOTE CONTROL FUNCTIONS

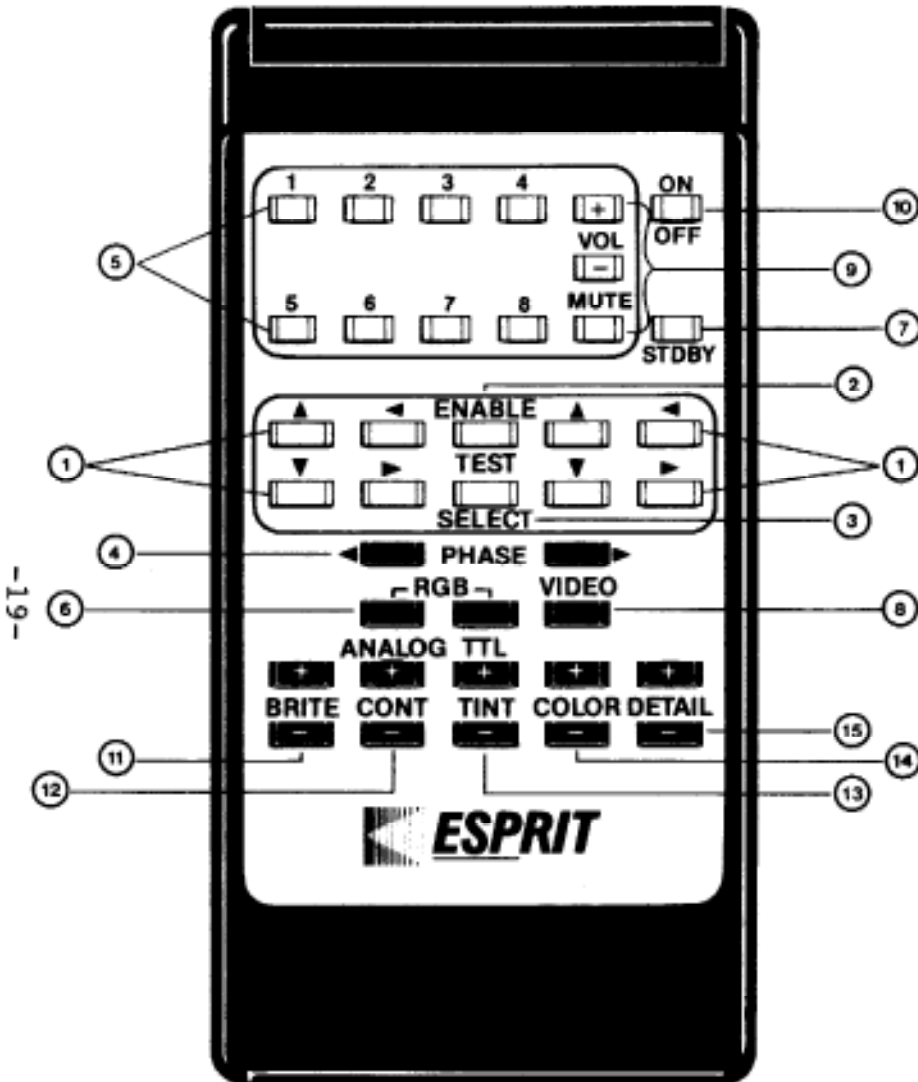

1. CONVERGENCE centering control
2. TEST ENABLE to select test mode
3. TEST SELECT to choose test pattern
4. PHASE adjusts for various convergence and can be stored for instant recall
5. STORE up to eight different patterns and control operation of up to 15 buttons from this one remote
6. RGB can select between the RGB or the EGA/CGA TTL input
7. STANDBY puts the projector in standby with the picture blanked
8. VIDEO selects video inputs
9. MUTE and volume controls for audio amplifier
10. ON/OFF switches power to the projector
11. BRIGHTNESS provides lighter or darker picture
12. CONTRAST adjusts white/black levels
13. TINT refines color hues
14. COLOR intensity adjustment
15. DETAIL adjusts for sharper/softer picture

MOUNTING BRACKET - Provides means of mounting projector to pipe in ceiling or floor stand for quick, convenient installation.

RGB/VIDEO SWITCHER - Switches up to 8 RGB and 8 VIDEO sources with stereo audio for use with ESP projectors.

SHIPPING/CARRYING CASE - Provides safe, convenient case with dolly wheels for portable applications of ESP projectors.

ULTRA HIGH RESOLUTION LENSES - Eight element ultra high resolution glass lenses

## Chapter 5

### SPECIFICATIONS

#### 5.1 ESPRIT 300 specifications

Light Output:	400 Lumens peak white
Electronic Resolution:	768 Lines per picture width RGB 330 Lines per picture width NTSC video
Composite Video Input:	Composite video (1vpp typical) negative sync. 75 ohm termination or looped through BNC. Manual/Automatic sensing quad decoder: NTSC 3.58, NTSC 4.43, PAL, SECAM.
Analog RGB video input:	Red, Green, Blue BNC's: RS-170 compatible. Composite sync or sync on green (100mv to TTL levels).
Scanning Rate:	Horizontal: 14 khz to 17 khz. Vertical: 40 hz to 100 hz.
Retrace time:	Horizontal: 8 microseconds minimum. Vertical: 600 microseconds minimum.
Cathode Ray Tubes:	Electrostatically focused, non-browning, optically coated CRT assemblies operated at 33 kv with 1 ma beam current.
Throw distance:	Approximately 1.5 times image width.
Picture size:	4 ft. (1.2m) to 12 ft. (3.6m) horizontal width (infinitely variable). Up to 25' with optional wide angle lenses.
Mains input:	115VAC 60Hz or 230VAC 50Hz (+10% -15%).
Power consumption:	400 watts maximum.
Optics:	High resolution coated f1.0 lenses
Weight:	75 lbs. (34.1kg)
Dimensions:	7 3/4" (19.68cm) high x 21" (53.34cm) wide x 29 1/4" (77.47cm) long

## 5.2 ESPRIT 500 specifications

Light Output: 400 Lumens peak white

Electronic Resolution: 1024 Lines per picture width RGB  
330 Lines per picture width NTSC video

Composite Video Input: Composite video (lvpp typical) negative sync.  
75 ohm termination or looped through BNC.  
Manual/Automatic sensing quad decoder: NTSC 3.58, NTSC 4.43, PAL, SECAM.

Analog RGB video input: Red, Green, Blue BNC's: RS-170 compatible.  
Sync: Composite sync or sync on green (100mv to TTL levels). Automatic sync polarity select (composite sync only).

TTL RGB video input: 9 pin 'D' RGB input connector.  
Internal CGA/EGA auto sensing interface.  
Adjustable blue video enhancement.

Scanning Rate: Horizontal: 14 khz to 28 khz.  
Vertical: 40 hz to 100 hz.

Retrace time: Horizontal: 5.5 microseconds minimum.  
Vertical: 400 microseconds minimum.

Cathode Ray Tubes: Electrostatically focused, non-browning, optically coated CRT assemblies operated at 33 kv with 1 ma beam current.

Throw distance: Approximately 1.5 times image width.

Picture size: 4 ft. (1.2m) to 12 ft. (3.6m) horizontal width (infinitely variable). Up to 25' with optional wide angle lenses.

Mains input: 115VAC 60Hz or 230VAC 50Hz (+10% -15%).

Power consumption: 400 watts maximum.

Optics: High resolution coated f1.0 lenses.

Weight: 75 lbs. (34.1kg).

Dimensions: 7 3/4" (19.68cm) high x 21" (53.34cm) wide x 29 1/4" (77.47cm) long.

## Chapter 6

### OPERATION

#### 6.1 GENERAL

This section of the manual will familiarize you with the connections, controls, and parameters available for operation of your projector. It should be all you need to operate your projector, once it has been installed and set-up (focused and registered).

To get to this point in the manual, it is assumed that you have read the section on installation and that the unit has been set-up. The way in which your unit operates will, in some ways, depend on how it has been installed. This means, for instance, that a unit installed with a single signal input will not operate exactly the same as a unit with special options such as an RGB/VIDEO Switcher. If your installation has special options, refer to the technical information furnished with the options for additional information.

#### 6.2 REMOTE CONTROL DESCRIPTION

The ESPRIT remote control unit can be either wired or infrared. The Infrared Remote Control communicates with the Infrared Remote Receiver, which must be properly connected to your projector.

The only maintenance that will be required on the Infrared Remote Control is to check that the battery and the six conductor cable between the RJ-13C jacks on the IR receiver and the projector are in good operating condition.

Refer to Figure 4 for the name, location, and brief description of the buttons on the Remote Control.

#### 6.3 BACK PANEL DESCRIPTION

The back panel of the projector is where all connectors are located. Also located on the back panel are several other devices such as, the power rocker switch, access to the main power fuse and voltage select barrel switch, etc.

Refer to Figure 2 or 3 for the name, location, and brief description of the back panel.

#### 6.4 INPUT SIGNALS

There are two different input connector configurations available on the ESPRIT 300 projector and three input connector configurations available on the ESPRIT 500. They are the Composite video input, the Analog RGB input, and the TTL RGB input (ESPRIT 500 only.) Each is discussed below.

##### 6.4.1 COMPOSITE VIDEO INPUTS

The composite video input is a standard BNC connector and a



loop through connector. To loop a signal through the projector, remove the terminator from the loop through BNC and connect any 75 ohm terminated load. If the loop through BNC connector is not being used for loop through purposes, it must have the 75 ohm terminator in place on the connector or loss of picture quality will occur.

The composite video input will automatically decode any of the four quad standards. The four standards are NTSC 3.58, PAL(4.43), SECAM, and NTSC 4.43. The automatic selection process may be overridden by changing the VIDEO SELECT switch on the registration panel from the AUTO to the MANUAL position.

When the Video Select switch is in the manual position, each time the the VIDEO button on the remote control is depressed, the projector selects a different decoding standard. After each of the four standards has been selected, depressing the button again will wrap around and start the process all over again.

#### 6.4.2 RGB INPUTS

##### 6.4.2.1 ANALOG RGB

The analog RGB signal falls into three major categories, three wire, four wire, and five wire. The ESPRIT projector will automatically configure itself properly if the input signals are applied to the proper connectors.

For three wire RGB, the signals are red video, green video (with composite sync), and blue video. These signals would be applied to the RED, GREEN, and BLUE BNC connectors respectively. (Ensure that there is no input connected to the SYNC BNC connector and the VERT DRIVE BNC connector on the Quad Video board.)

For four wire RGB, the signals are red video, green video, blue video, and composite sync. These signals would be connected to the RED, GREEN, BLUE, and SYNC BNC connectors respectively. (Ensure that there is no signal connected to the VERT DRIVE BNC connector on the Quad board)

For five wire RGB, the signals are red video, green video, blue video, horizontal sync, and vertical sync. These signals would be connected to the RED, GREEN, BLUE, SYNC, and VERT DRIVE BNC connectors respectively.

The only operator controls that effect the Analog RGB image are the Brightness control on the Infrared Remote Control, and the R, G, and B Gain controls (below their respective BNC connectors) on the rear of the projector. Set the Brightness control on the remote control for the threshold of visibility, and adjust the R, G, and B Gain controls as high as possible without causing defocusing while obtaining the desired grey scale.

##### 6.4.2.2 TTL RGB (ESPRIT 500 ONLY)

The TTL RGB input is a nine pin "D" connector configured to accept IBM PC (or compatible) input of either CGA or EGA Resolution. The TTL input automatically changes to accept either mode. For pinout reference data refer to your computer manual.

The Blue Enhance switch on the rear panel provides for a

more visible blue when energized. To change to amount of blue enhancement, refer to Chapter 7 Paragraph 7.9.

## 6.5 SYSTEM OPERATION

### 6.5.1 SYSTEM TURN-ON

If your projector has been installed and set-up properly, and the main power rocker switch on the rear of the projector is ON, all you have to do now is operate the remote control buttons.

The steps you should take to ensure that you are ready to go are listed below. (Refer to Figures 2, 3, and 4)

(1) Ensure that the projector is plugged into an active approved standard AC outlet of the proper voltage.

(2) Ensure that an active input signal of the desired type is properly connected to the projector.

(3) Ensure that the infrared remote control receiver or the wired remote control has the cable connected between it and the projector rear panel.

(4) Turn on the main power rocker switch on the rear of the projector. (The switch is ON when the red "O" can not be seen) This should cause the LCD display to give the message "ESP MODEL 300" or "ESP MODEL 500" as the case may be.

If all of the conditions listed above have been met, it is now time to depress the Remote Control "ON" button. The projector will go thru a sequence of events and be ON in the default (last used) mode of operation when the sequence is finished.

First the red LED on the rear panel (above the fan) will light up, the fan motors may be heard running, and the LCD display will give the message "STATUS OK". Next the projector will change to the mode of operation it was using when turned off and the LCD display will give a message telling you what mode it selected.

### 6.5.2 IMAGE QUALITY CHECK

It is advisable at this point to depress the TEST button. When the button is depressed a crosshatch pattern will be displayed. (NOTE: IT IS NECESSARY TO HAVE A SYNC SOURCE OF THE DESIRED FREQUENCY APPLIED TO THE VIDEO INPUT BNC CONNECTOR IN ORDER TO USE THE TEST PATTERN) If the crosshatch pattern observed is clear, focused, and properly aligned, it is time to select the desired signal input and use the projector. If the pattern is not properly focused and aligned, go to Section 7.4 and perform the desired procedure. Allow 20 minute warm up period for alignment verification.

### 6.5.3 SIGNAL SOURCE SELECTION

The signal source is selected by the remote control buttons. You have choices determined by three buttons to select your input. The possible choices are video, analog RGB, and with the ESPRIT 500, TTL RGB or internal test.

When you have a composite video signal connected to the video input BNC connector, and desire to select it as the source, depress the video button (black). When you are in the automatic mode of operation, the projector will decode any of the four quad standards and project them on the screen. When you are in the manual mode of operation each time the video button is depressed, the quad standard decoder will step to the new standard to decode. The sequence of selection is NTSC 3.58, PAL, SECAM, NTSC 4.43. The switch to select either automatic or manual signal selection is on the registration panel.

When you have an analog RGB signal connected to the projector, you will select it by depressing the ANALOG RGB button (black) on the remote control. The selection of the analog RGB input is the same for three, four, or five wire inputs.

Refer to Section 7.4.2.1 for information on setting the level of the RGB gain control potentiometers.

(ESPRIT 500 ONLY) When you have a TTL RGB signal connected to the nine pin "D" connector on the rear of the projector, you may select it by depressing the TTL RGB button (black) on the remote control. The projector will automatically configure itself for either CGA or EGA inputs. The ESPRIT 300 projector will ignore the TTL RGB command.

### 6.5.4 PHASE ADJUSTMENT-SINGLE PROJECTOR MODE

Prior to the development of the ESPRIT projectors, one problem frequently encountered was improper framing of the projected image on the raster. This was seen as characters lost on either the right or left side of the image. The ESPRIT remote control has two phase controls buttons (black), one to move the data to the left and one to move the data to the right so that the data may be properly framed.

### 6.5.5 IMAGE QUALITY ADJUSTMENTS

There are five sets of buttons (black) across the bottom of the remote control that control image quality. Each set has a button marked + to increase a setting and a button marked - to decrease a setting.

The five sets of buttons are described below.

**BRIGHTNESS:** The + and - brightness buttons control the brightness level of the projected image. This is the only image quality button that has an effect in all three modes Analog RGB, TTL RGB, and Video. Adjust the brightness level until the black portions

of a projected image are black, but detail in shaded areas is not lost.

**CONTRAST:** The + and - contrast buttons control the color intensity in the video mode only. The contrast buttons will change the amount of image intensity. If image defocusing or loss of detail occurs, decrease either contrast or brightness or both.

**TINT:** The + and - tint buttons control the hue of the video NTSC mode only. If facial tones or objects appear TOO GREEN, increase the tint setting by depressing the + button. If facial tones appear TOO PURPLE, decrease the tint setting by depressing the - button.

**COLOR:** The + and - color buttons control the color intensity of the image in video mode only. If the image appears TOO PALE or WEAK, depress the + button and if the image appears FLUSHED or TOO BRIGHT, depress the - button.

**DETAIL:** The + and - detail buttons control the crispness of the picture in video NTSC mode only. If the image appears soft, depress the + button. If the image appears grainy, depress the - button. The desired setting of detail is as high as allowed without the image appearing grainy.

#### 6.5.6 STANDBY

The projector provides the user with the capability of removing the projected image from the screen, without changing any image settings or cooling down of the projector. The operator need simply depress the standby (yellow) button on the remote control to remove the image and depress a Video or RGB button to restore the image.

#### 6.5.7 TEST PATTERN

The test pattern may be accessed from any mode of operation by depressing the test enable (brown) button on the remote control. The pattern that will appear is the crosshatch pattern. To change the test pattern from the crosshatch to another pattern, the test select (brown) button on the remote is used. There are two different patterns available to the user, the crosshatch pattern and the dots pattern. (REMEMBER THAT A SYNC SIGNAL OF THE DESIRED FREQUENCY MUST BE APPLIED TO THE VIDEO IN BNC IN ORDER FOR THE TEST GENERATOR TO WORK)

#### 6.5.8 RASTER ALIGNMENT ADJUSTMENTS

On rare occasions the red, green, and blue image components may become misaligned. To determine if your alignment is correct, depress the test enable (brown) button on the remote

control. If the three images red, green, and blue are superimposed so that a white crosshatch is displayed, the image is aligned properly. If the three images are not in alignment, the red and blue images must be moved to superimpose the green image. There are four red buttons and four blue buttons on the remote control to move the red and blue images respectively. Move the red and blue images, using these buttons, so that they do superimpose the green raster.

#### NOTE

THE RASTER ALIGNMENT BUTTONS WILL ONLY ALLOW THE RED AND BLUE IMAGES TO BE ADJUSTED WHILE IN THE INTERNAL TEST MODE.

#### 6.5.9 VOLUME AND MUTE

There are three buttons (grey) on the remote control labeled volume +, volume -, and mute which are for use with the optional 10 Watt Stereo Amplifier. These buttons will have no effect upon the operation of your projector if it is an ESPRIT 500 or the 10 watt audio amplifier option is not installed in your ESPRIT 300.

NOTE: The audio amplifier is a standard option for the ESPRIT 300. It is also an option for the ESPRIT 500 where it is an alternative to the TTL feature.

#### 6.5.10 MULTIPLE PROJECTOR MODE (ESPRIT 500 ONLY)

The ESPRIT 500 projector has the ability to be ganged with other projectors and operated from a single remote control. When in the multiple projector mode, the commands that you desire to send to one specific projector require the projector number (grey) button being depressed (each time) prior to depressing the function button. When you desire to send a command to all of the projectors simultaneously, do not select a projector number, simply depress the function button.

#### 6.5.11 PROJECTOR NUMBER (MULTIPLE PROJECTOR MODE)

The number assigned to a given projector, in a multiple projector installation, is determined by its position in the loop through chain. Projector number one is always the projector connected to the Infrared receiver or wired remote control. The RS-232 SLAVE jack on that projector will be connected to the next projectors RS-232 HOST jack, making this projector number two. The RS-232 SLAVE jack on projector number two will be connected to the RS-232 HOST jack on the next projector, making it projector number three, etc. Refer to Chapter 10, RS-232 INTERFACE DATA, for further information.

## Chapter 7

### CHANGING PROJECTOR PARAMETERS

#### 7.1 CHANGING PICTURE SIZE

To change picture size, the projector must be moved closer to the screen for smaller projected images and further from the screen for larger projected images. When this is done, two things happen to the projected image. The first is that the image defocuses and the second is that the red, green, and blue images separate, on the horizontal plane. To determine approximately where the projector must be mounted for a given size screen, multiply the desired screen width by 1.5 to obtain the approximate throw distance. To refocus the projected image refer to Section 7.4.1.1 (lens focus). To superimpose the three projected images, refer to Section 7.4.1.2 (lateral lens adjust).

#### 7.2 CHANGING DEFLECTION ANGLE

The optimum image will be obtained when the lenses are at right angles to the center of the screen. Since it is often necessary to floor or ceiling mount the projector, provisions have been built into it for off-angle (in the vertical plane) projection. Since off-angle projection produces a different throw distance, from the projector to the top and the bottom of the screen, some top and bottom defocusing will normally occur. This condition can be minimized by tilting the screen so that it is closer to on-axis.

The second effect that occurs when the deflection angle is changed from on-axis is known as keystone effect. This effect is observed as a trapezoid shaped image. This condition can be corrected and is part of the registration procedure. For your initial set-up and registration, this will be provided by the selling dealer.

To ceiling mount the projector, it must be inverted so that the mounting bracket will be on top of the unit. To operate the projector in the inverted position, the horizontal and vertical sweeps must be reversed. To reverse the sweeps, refer to Chapter 7 Paragraph 7.5.

#### 7.3 REAR SCREEN PROJECTION

As discussed in Chapter 4 (INSTALLATION), rear screen projection provides definite advantages in some applications. If the screen must be used in a high ambient light area, rear screen projection is usually the only way to go. The throw distance is the same for rear projection as it is for front projection so provide for sufficient depth in the projector room. To reduce the possibility of hot spots, off-axis (in the vertical plane) mounting is often employed. If your projector employs rear screen projection, a sweep must be reversed, vertical for ceiling mounted and horizontal for table mounted.

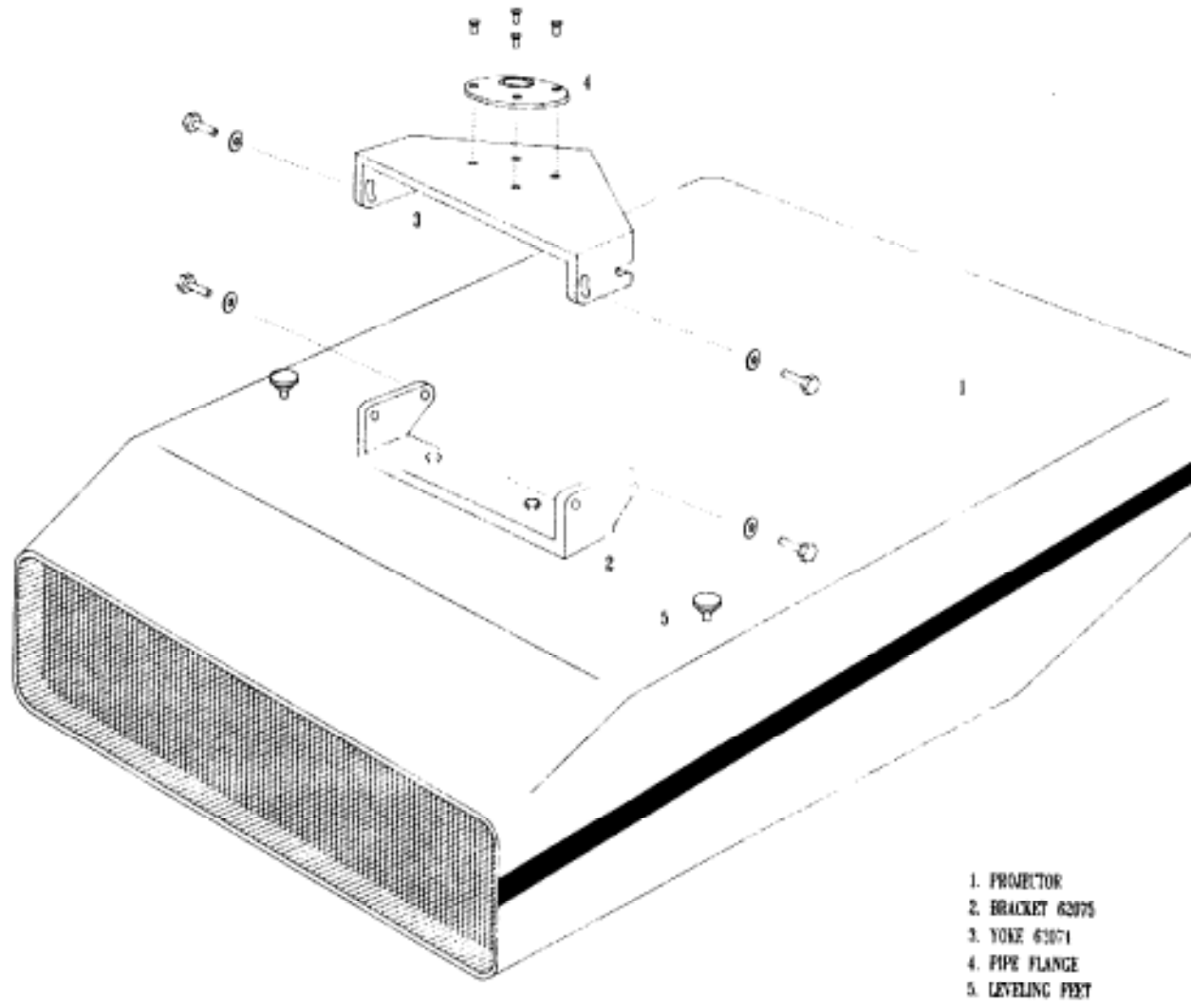

FIGURE 5



The registration procedure must also be performed, refer to Section 7.4.

## 7.4 REGISTRATION PROCEDURE

### CAUTION

DO NOT LEAVE THE TEST PATTERN ON AT FULL INTENSITY FOR ANY PERIOD IN EXCESS OF THIRTY MINUTES OR THE TEST PATTERN WILL BE PERMANENTLY ETCHED INTO THE SCREEN PHOSPHOR.

To satisfactorily perform the registration procedures, the projector MUST BE mounted in the same physical position and orientation that it will be in when it is used. The influence from the magnetic field of the earth will affect the registration if the projector is moved or inverted. PRIOR TO performing the registration procedure the sweep reverse plugs MUST BE in the direction they will be used in.

#### 7.4.1 MECHANICAL

##### 7.4.1.1 LENS FOCUS

(Refer to figure 5) In order to focus the lenses it will be necessary to remove the lens cover panel, which is secured with two 1/4 turn fasteners (8) located on the sides near the lens end of the projector. To remove the panel, simply turn the fasteners 1/4 turn counterclockwise, with a screwdriver, and lift the cover panel off.

Depress the top brown button on the remote control, labeled Test Enable, to turn the crosshatch test pattern "ON". (NOTE: A SYNC SIGNAL AT THE DESIRED FREQUENCY MUST BE APPLIED TO THE "VIDEO IN" BNC CONNECTOR IN ORDER FOR THE TEST GENERATOR TO OPERATE)

Each lens should be focused individually. Use the cutoff switches on the registration panel to turn off the two lenses not being focused. (Refer to Figure 7)

There are several different types of lenses that may be used on your projector, but they all fall into two categories. (Refer to Figure 6) The first category is single adjustment lenses, which are adjusted for the best over-all focus of the image with one control. The second category is dual adjustment type lenses. The adjustment which gives the most effect is the primary focus adjustment and the other adjustment is the secondary focus adjustment.

If the lenses that you are using are the single adjustment type, adjust the single adjustment for the best over-all focus while observing the test pattern.

If the lenses you are using are the dual adjustment type, adjust the primary focus adjustment for the best focus in the center of the test pattern and then adjust the secondary adjustment for the best edge focus. By using the two adjustments it should be possible to obtain focus throughout the image.

Follow this procedure to focus all three lenses.



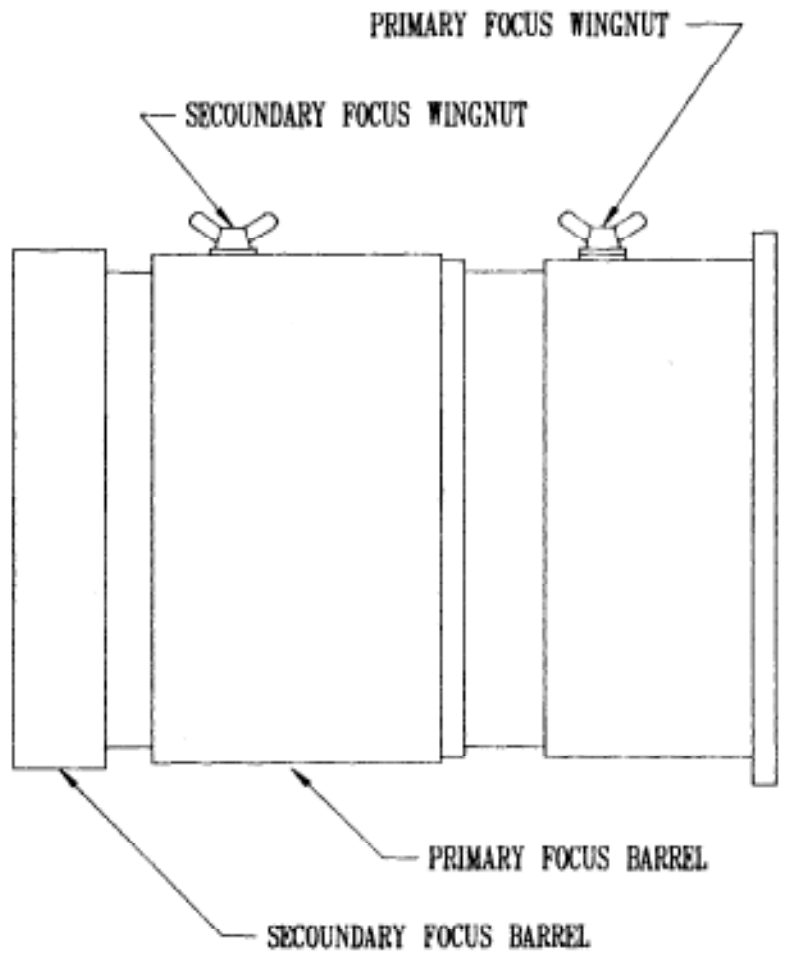

FIGURE 6

NOTE: The electronic focus should not change and therefore should not need to be adjusted. In the event that you are not satisfied with the focus after performing the mechanical focus procedure, the electronic focus may be adjusted by using the three controls between the Red and green CRTs. These controls are sealed but breaking the seal to perform this procedure will not void the warranty. (Refer to Paragraph 7.10)

#### 7.4.1.2 LATERAL LENS ADJUSTMENT

(Refer to Figures 5 and 7) Turn the registration switch, located on the registration panel, "OFF". The crosshatch test pattern will be utilized for this procedure.

With the lens cover off, as described in paragraph 7.4.1.1, locate the red and blue lateral lens adjustments Fig. 5. Adjust the red lateral lens adjustment so that the center vertical line in the red image exactly overlays the center vertical line in the green image on the screen. The next step is to locate the blue lateral lens adjustment and adjust it so that the center vertical line in the blue image exactly overlays the center vertical lines of the green and red images on the screen. The spot where the center horizontal line and the center vertical line cross should now be white.

#### 7.4.2 ELECTRICAL

The electrical portion of the registration procedure is divided into three stages. The crosshatch test pattern will be utilized for all three stages. The first stage is to make the green (master) raster as square and linear as possible. The second stage is to cause the red raster to exactly overlay the green raster. The third and final stage is to cause the blue raster to exactly overlay the red raster. When all three rasters are displayed, using the test pattern, the raster should be white throughout the raster.

(Refer to Figure 7) To explain registration procedures in this manual, registration controls pictured on the registration panel are described by name in the text. The projector is inverted when going from floor mount to ceiling mount. This causes no problem when using the pictures for performing the procedure but the names no longer describe the area affected. The names that describe the registration control pictures were chosen with the projector in the floor position. When the projector is inverted, top will become bottom and left will become right. Under these circumstances, always use the pictures above the controls and they will be correct.

While you are learning the registration procedure, refer to Figure 7 to determine the relationship between the control name and location.

##### 7.4.2.1 MASTER (GREEN) IMAGE ADJUSTMENTS

The first thing to do, with the crosshatch pattern displayed, is insure the Registration switch is "OFF" and turn "OFF"

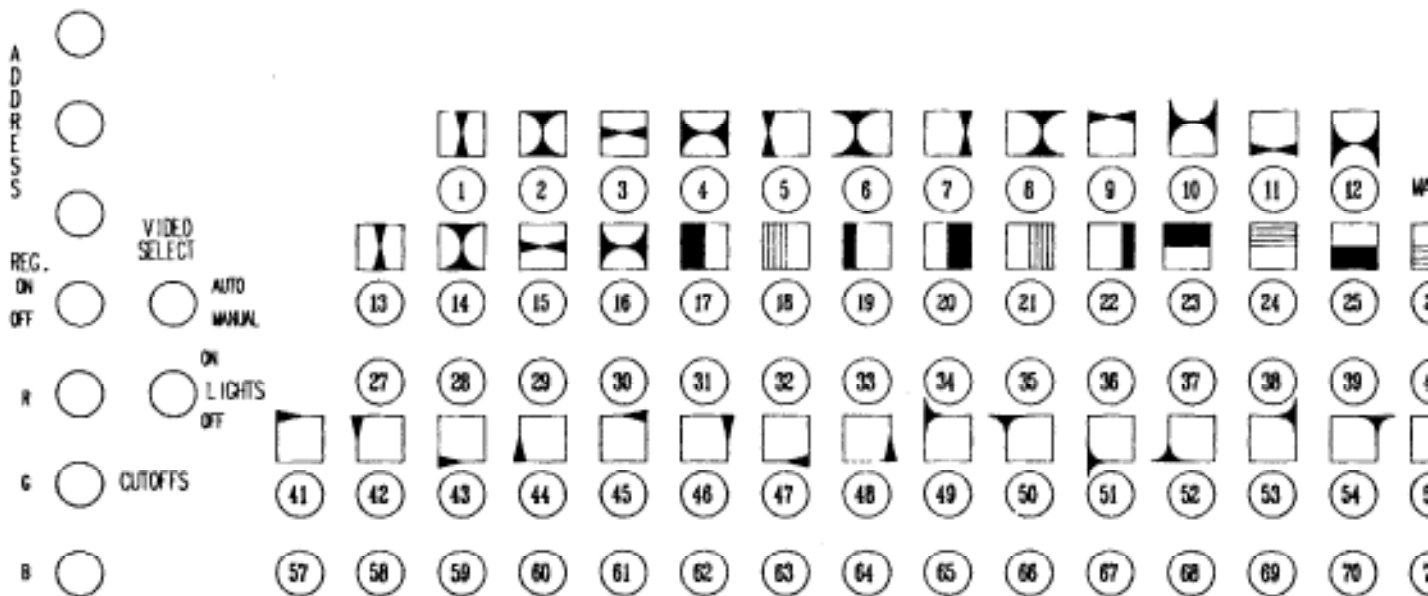

- 1. VERT LINE SKEW
- 2. VERT LINE BOW
- 3. HORZ LINE SKEW
- 4. HORZ LINE BOW
- 5. LEFT KEYSTONE
- 6. LEFT PINCUSHION
- 7. RIGHT KEYSTONE
- 8. RIGHT PINCUSHION
- 9. TOP KEYSTONE
- 10. TOP PINCUSHION
- 11. BOTTOM KEYSTONE
- 12. BOTTOM PINCUSHION
- 13. RED VERT LINE SKEW
- 14. RED VERT LINE BOW
- 15. RED HORZ LINE SKEW
- 16. RED HORZ LINE BOW
- 17. RED LEFT WIDTH
- 18. RED LEFT LINEARITY

- 19. RED LEFT EDGE
- 20. RED RIGHT WIDTH
- 21. RED RIGHT LINEARITY
- 22. RED RIGHT EDGE
- 23. RED TOP HEIGHT
- 24. RED TOP LINEARITY
- 25. RED BOTTOM HEIGHT
- 26. RED BOTTOM LINEARITY
- 27. BLUE VERT LINE SKEW
- 28. BLUE VERT LINE BOW
- 29. BLUE HORZ LINE SKEW
- 30. BLUE HORZ LINE BOW
- 31. BLUE LEFT WIDTH
- 32. BLUE LEFT LINEARITY
- 33. BLUE LEFT EDGE
- 34. BLUE RIGHT WIDTH
- 35. BLUE RIGHT LINEARITY
- 36. BLUE RIGHT EDGE

- 37. BLUE TOP HEIGHT
- 38. BLUE TOP LINEARITY
- 39. BLUE BOTTOM HEIGHT
- 40. BLUE BOTTOM LINEARITY
- 41. RED TOP LEFT N-S KEYSTONE
- 42. RED TOP LEFT E-W KEYSTONE
- 43. RED BOTTOM LEFT N-S KEYSTONE
- 44. RED BOTTOM LEFT E-W KEYSTONE
- 45. RED TOP RIGHT N-S KEYSTONE
- 46. RED TOP RIGHT E-W KEYSTONE
- 47. RED BOTTOM RIGHT N-S KEYSTONE
- 48. RED BOTTOM RIGHT E-W KEYSTONE
- 49. RED TOP LEFT N-S PINCUSHION
- 50. RED TOP LEFT E-W PINCUSHION
- 51. RED BOTTOM LEFT N-S PINCUSHION
- 52. RED BOTTOM LEFT E-W PINCUSHION
- 53. RED TOP RIGHT N-S PINCUSHION
- 54. RED TOP RIGHT E-W PINCUSHION

- 55. RED BOTTOM RIGHT N-S KEYSTONE
- 56. RED BOTTOM RIGHT E-W KEYSTONE
- 57. BLUE TOP LEFT N-S KEYSTONE
- 58. BLUE TOP LEFT E-W KEYSTONE
- 59. BLUE BOTTOM LEFT N-S KEYSTONE
- 60. BLUE BOTTOM LEFT E-W KEYSTONE
- 61. BLUE TOP RIGHT N-S KEYSTONE
- 62. BLUE TOP RIGHT E-W KEYSTONE
- 63. BLUE BOTTOM RIGHT N-S KEYSTONE
- 64. BLUE BOTTOM RIGHT E-W KEYSTONE
- 65. BLUE TOP LEFT N-S PINCUSHION
- 66. BLUE TOP LEFT E-W PINCUSHION
- 67. BLUE BOTTOM LEFT N-S PINCUSHION
- 68. BLUE BOTTOM LEFT E-W PINCUSHION
- 69. BLUE TOP RIGHT N-S PINCUSHION
- 70. BLUE TOP RIGHT E-W PINCUSHION
- 71. BLUE BOTTOM RIGHT N-S PINCUSHION
- 72. BLUE BOTTOM RIGHT E-W PINCUSHION

FIGURE 7

the red and blue images. These controls are on the left side of the registration panel. The object now is to make the Master (Green) image the proper size, linear, and correctly positioned on the CRT.

There are five internal control procedures that MUST BE CORRECT PRIOR TO performing the registration procedure using the external registration controls. They are Master Horizontal Keystone Adjustment procedure, Master East/West Pincushion adjustment procedure, Raster Sizing procedure, Vertical Centering procedure, Horizontal linearity adjustment procedure, and Vertical linearity adjustment procedure.

It will not always be necessary to perform all of the procedures but each of the following test must be met or the procedure must be performed.

1. Master Horizontal Keystone adjustment procedure test: Ensure the registration switch is "OFF" and apply sync only, at the desired frequency, to the "SYNC" BNC connector. (Ensure that nothing is connected to the Red, Green, and Blue BNC connectors.) With the Remote Control, select RGB Analog operation and increase brightness so that a raster can be observed on the screen. Turn "OFF" the Red and Blue CRTs. The outermost left and right vertical edges of the projected Green image must be parallel. If this test is not passed, refer to Paragraph 7.9.

2. Master East/West Pincushion adjustment procedure test: Ensure the registration switch is "OFF" and apply sync only, at the desired frequency, to the "SYNC" BNC connector. (Ensure that nothing is connected to the Red, Green, and Blue BNC connectors.) With the Remote Control, select RGB Analog operation and increase brightness so that a raster can be observed on the screen. Turn "OFF" the Red and Blue CRTs. The outermost left and right vertical edges of the projected Green image must be straight. If this test is not met, refer to paragraph 7.10.

3. Raster Sizing procedure test: Ensure the registration switch is "OFF" and apply sync only, at the desired frequency, to the "SYNC" BNC connector. (Ensure that nothing is connected to the Red, Green, and Blue BNC connectors.) With the Remote Control, select RGB Analog operation and increase brightness so that a raster can be observed when looking into the green CRT. The green raster must just touch the corners of the CRT, at the widest point, without over scanning. If this test is not met, refer to Paragraph 7.11.

4. Horizontal Linearity adjustment procedure test: Connect a sync signal of the desired frequency to the "Video IN" BNC connector. Select the internal crosshatch pattern with the red and blue rasters turned "OFF". Measure the horizontal width of a crosshatch box on the left side of the screen and compare it with the width of a crosshatch box on the right side of the screen. The width of the box can not vary by more than 20%. If this test

is not met, refer to paragraph 7.12.

5. Vertical Linearity adjustment procedure test: Connect a sync signal of the desired frequency to the "Video IN" BNC connector. Select the internal crosshatch pattern with the red and blue rasters turned "OFF". Measure the vertical size of a crosshatch box on the top of the screen and compare it with the size of a crosshatch box on the bottom of the screen. The size of the box can not vary by more than 20%. If this test is not met, refer to paragraph 7.13

Once the preceding five procedures have been checked, the next step is to turn the Registration switch "ON" and register the Green (Master) image. The MASTER controls are all on the top row of the registration panel. The chart below lists the control names and the desired result of adjusting the control.

CONTROL NAME	DESIRED RESULT
Vertical line skew	Center vertical crosshatch line is parallel to the vertical plane of the screen.
Vertical line bow	Center vertical lines is straight.
Horizontal line skew	Center horizontal line is parallel to the horizontal plane of the screen.
Horizontal line bow	center horizontal line is straight
Left keystone	Left edge vertical line is parallel to the vertical plane of the screen.
Left pincushion	Left edge vertical line is straight.
Right keystone	Right edge vertical line is parallel to the vertical plane of the screen.
Right pincushion	Right edge vertical line is straight.
Top keystone	Top horizontal line is parallel to the horizontal plane of the screen.
Top pincushion	Top horizontal line is straight.
Bottom keystone	Bottom horizontal line is parallel to the horizontal plane of the screen.
Bottom pincushion	Bottom horizontal line is straight.

The green image should now be rectangular and all lines either parallel or perpendicular. From this point on in the registration procedure DO NOT change any of the Master controls.

#### 7.4.2.2 RED IMAGE ADJUSTMENTS

Leave the registration switch "ON" and turn "ON" the red image by using the Red Cutoff switch on the left side of the registration panel. You should now have the green and the red crosshatch patterns projected. The purpose of this section of the procedure is to cause the red crosshatch pattern to exactly overlay the green crosshatch pattern. The second row down on the registration panel is where the red primary adjustment controls are located. Listed below are the red primary controls and the desired results of adjusting these controls. Before these controls can be adjusted the Red raster must be centered, using the Remote Control. Use the four red buttons on the remote control to move the red image so that the intersection of the center red vertical and center red horizontal lines exactly overlays the intersection of the center green vertical line and the center green horizontal line. After the center of the red raster is lined up with the center of the green raster, perform the adjustments listed below.

CONTROL NAME	DESIRED RESULT (POSITION OF ALIGNMENT)
Vertical line bow	Center red vertical crosshatch line is straight.
Vertical line skew	Center red vertical crosshatch line exactly overlays the center green vertical line. (The red horizontal centering control on the Remote Control may be necessary to obtain proper overlay)
Horizontal line bow	Center red horizontal line is straight.
Horizontal line skew	Center red horizontal line exactly overlays the green center horizontal line. (The red vertical centering control on the Remote Control may be necessary to obtain exact overlay)
Left width	Overlay red vertical lines on inner 2/3 of left half of green image.
Left linearity	Overlay red vertical lines on outer 1/3 of left half of green image.
Left edge	Overlay red left vertical edge on green left vertical edge.
Right width	Overlay red vertical lines on inner 2/3 of right half of green image.

Right linearity	Overlay red vertical lines on outer 1/3 of right half of green image.
Right edge	Overlay red right vertical edge on green right vertical edge.
Top height	Overlay red horizontal lines on inner 2/3 of top half of green image.
Top linearity	Overlay red horizontal lines on outer 1/3 of the top half of the green image.
Bottom height	Overlay red horizontal lines on inner 2/3 of bottom half of green image.
Bottom linearity	Overlay red horizontal lines on outer 1/3 of bottom half of green image.

Now the Red image should overlay the Green image with a few exceptions in the corners. The next step is to use the Red Corner controls in the fourth row from the top on the registration panel. The purpose of this section of the procedure is to cause the red image to exactly overlay the green image in the corners.

CONTROL NAME	DESIRED RESULT (POSITION OF ALIGNMENT)
TOP LEFT N-S KEYSTONE	Red horizontal line overlays green image in upper inner left corner area.
TOP LEFT E-W KEYSTONE	Red vertical line overlays green image in upper inner left corner area.
BOTTOM LEFT N-S KEYSTONE	Red horizontal line overlays green image in lower inner left corner area.
BOTTOM LEFT E-W KEYSTONE	Red vertical line overlays green image in lower inner left corner area.
TOP RIGHT N-S KEYSTONE	Red horizontal line overlays green image in upper inner right corner area.
TOP RIGHT E-W KEYSTONE	Red vertical line overlays green image in upper inner right corner area.
BOTTOM RIGHT N-S KEYSTONE	Red horizontal line overlays green image in lower inner right corner area.

BOTTOM RIGHT E-W KEYSTONE	Red vertical line overlays green image in lower inner right corner area.
TOP LEFT N-S PINCUSHION	Red horizontal line overlays green image in upper outer left corner area.
TOP LEFT E-W PINCUSHION	Red vertical line overlays green image in upper outer left corner area.
BOTTOM LEFT N-S PINCUSHION	Red horizontal line overlays green image in lower outer left corner area.
BOTTOM LEFT E-W PINCUSHION	Red vertical line overlays green image in lower outer left corner area.
TOP RIGHT N-S PINCUSHION	Red horizontal line overlays green image in upper outer right corner area.
TOP RIGHT E-W PINCUSHION	Red vertical line overlays green image in upper outer right corner area.
BOTTOM RIGHT N-S PINCUSHION	Red horizontal line overlays green image in lower outer right corner area.
BOTTOM RIGHT E-W PINCUSHION	Red vertical line overlays green image in lower outer right corner area.

The Red image should now overlay the Green image throughout the crosshatch pattern.

#### 7.4.2.3 BLUE IMAGE ADJUSTMENTS

This step is to overlay the blue image on the Green and Red images. Since the blue image is difficult to see when used with the Green image, it is best to turn "OFF" the Green image now and turn on the Blue image. This will leave the Red and Blue cross-hatch patterns on the screen. The Blue image adjustments are the same as the Red image adjustments with the exception of the actual controls used. While overlaying the Blue image on the Red image, use the Blue controls in the third and fifth rows from the



top of the registration panel and follow the same procedure you used with the corresponding red controls. When you have finished overlaying the Blue image on the Red image, turn "ON" the Green image and the crosshatch pattern should be white throughout the projected image. Touch up the necessary controls until the entire image is white and then you are finished with the registration procedure. Select the desired input signal with the remote control and enjoy the result.

## 7.5 SWEEP REVERSAL PROCEDURES

### 7.5.1 HORIZONTAL SWEEP REVERSAL PROCEDURE

#### WARNING

DO NOT TRY TO SERVICE THE HORIZONTAL SWEEP REVERSE PLUG WHILE THE PROJECTOR IS ENERGIZED. IF THE SWEEP REVERSE PLUG IS REMOVED WHILE THE PROJECTOR IS ENERGIZED, HIGH VOLTAGE SHOCK WILL RESULT AND THE PROJECTOR WILL BE DAMAGED.

If it has been determined that the horizontal sweep requires reversal, observe the horizontal sweep indicator (refer to Figure 5) to determine its color. (Red or Green) After the sweep has been reversed, the color of the light should have changed.

To reverse the sweep, turn the projector "OFF" and DISCONNECT the power cord.

1. Remove the Top Cover. It is held on by two 1/4 turn fasteners on the sides of the projector near the rear.

2 Tilt up the Registration board which is across the rear of the projector. The boards under the Registration board are now exposed.

3. The Horizontal sweep reversal plug is on the lens end of the HOT board (65151) located in the slot against the right side of the projector, when it is viewed from the rear. Pull the sweep reverse plug out, turn it end for end (180°), and plug it in again. NOTE: Recheck raster centering.

4. Lower the Registration board and snap it in position.

5. Replace the top cover, plug in the power cord, and energize the projector. The horizontal sweep indicator should now be the other color and the horizontal sweep should be reversed.

### 7.5.2 VERTICAL SWEEP REVERSAL PROCEDURE

#### WARNING

DO NOT TRY TO CHANGE THE POSITION OF THE VERTICAL REVERSE SWITCH. CHANGING THE POSITION OF THIS SWITCH WHILE THE PROJECTOR IS ENERGIZED WILL RESULT IN DAMAGE TO THE EQUIPMENT.

If it has been determined that the vertical sweep requires reversal, observe the vertical sweep indicator (refer to Figure 5) to determine its color. (Red or Green) After the sweep has been reversed, the color should have changed.

To reverse the sweep, turn the projector "OFF" and DISCONNECT the power cord.

1. Remove the Top Cover. It is held on by two 1/4 turn fasteners on the sides of the projector near the rear.
2. Tilt up the Registration board which is across the rear of the projector. The boards under the Registration board are now exposed.
3. The Vertical Sweep Reverse switch is on the Vertical Deflection board (65167) which is in the third slot from the right side of the projector, when viewed from the rear. By looking down into the gap between the power supply box and the vertical deflection board the switch can be seen. The switch is about two inches from the rear panel and near the mother board. Change the position of the switch. This can be done by using a screwdriver to flip the switch. (Be sure the projector is "OFF")
4. Lower the Registration board and snap it in position.
5. Replace the top cover, plug in the power cord, and energize the projector. The Vertical Sweep Indicator should now be the other color and the vertical sweep should be reversed.

#### 7.6 BLANKING PROCEDURES

The purpose of the blanking procedures is to provide clean, sharp edges to the projected image, without losing any of the video. Since the VERTICAL writing time varies from one type of signal to the next, several procedures have been provided. There are three sets of top and bottom blanking controls. The NTSC controls which affect the top and bottom of the NTSC 3.58 and NTSC 4.43 images only. The PAL/SECAM controls which affect the top and bottom of the PAL and SECAM images only. The RGB controls which affect the top and bottom of the RGB images only.

There is only one set of left and right blanking controls which can affect the left and right side of all video images.

All of the blanking controls are located internally on the RGB board. To gain access to the blanking controls, perform the following procedure.

1. Remove the Top Cover. It is held on by two 1/4 turn fasteners on the sides of the projector near the rear.
2. Tilt up the Registration board which is across the rear of the projector. The boards under the Registration board are now exposed.

3. The blanking controls are all together on the top of the RGB board which is the second board from the left side when viewed from the rear of the projector. The controls are all identified with their circuit symbol numbers just above each control.

4. When the controls have been identified, perform the following procedures as needed.

#### 7.6.1 NTSC TOP AND BOTTOM BLANKING PROCEDURE

1. Use an "off the air" NTSC 3.58/4.43 video signal for NTSC top blanking procedure.

2. TOP: The top of the image should be adjusted so that the VITS portion of the image is not seen, without losing any of the video. This may be accomplished by using the NTSC Top Blanking control (R-116), which is the fifth control from the rear on the RGB board.

3. Use the output of a tape source for NTSC bottom blanking procedure.

4. BOTTOM: The bottom of the image should be adjusted so that any tape head switching noise is not seen, without losing any of the video. This may be accomplished by using the NTSC Bottom Blanking control (R-119), which is the control nearest the lenses on the RGB board.

#### 7.6.2 RGB TOP AND BOTTOM BLANKING PROCEDURE

1. Select your RGB source with the longest vertical writing time (shortest vertical retrace time) to perform the RGB top and bottom adjustment procedure.

2. TOP: The top of the image should be adjusted so that the faint raster seen above the image can not be seen, without losing any of the image. This may be accomplished by using the RGB Top Blanking control (R-114), which is third control from the rear on the RGB board.

3. BOTTOM: The bottom of the image should be adjusted so that the faint raster at the bottom of the image can not be seen, without losing any of the image. This may be accomplished by using the RGB Bottom Blanking control (R-117), which is the third control from the front of the projector on the RGB board.

#### 7.6.3 PAL/SECAM TOP AND BOTTOM BLANKING PROCEDURE

1. Use an "off the air" PAL/SECAM video signal for PAL/SECAM top blanking procedure.

2. TOP: The top of the image should be adjusted so that the VITS portion of the image is not seen, without losing any of the

video. This may be accomplished by using the PAL/SECAM Top Blanking control (R-115), which is the fourth control from the rear on the RGB board.

3. Use the output of a tape source for PAL/SECAM bottom blanking procedure.

4. BOTTOM: The bottom of the image should be adjusted so that any tape head switching noise is not seen, without losing any of the video. This may be accomplished by using the PAL/SECAM Bottom Blanking control (R-118), which is the second control from the lens end of the projector, on the RGB board.

#### 7.6.4 LEFT AND RIGHT SIDE BLANKING PROCEDURE

1. Select an "off the air" PAL or NTSC signal to perform the horizontal blanking procedure.

2. LEFT EDGE: The left edge of the image should be adjusted so that the faint raster to the left of the image can not be seen. This may be accomplished by using the Left Horizontal Edge Blanking control (R-112), which is the control nearest the rear of the projector, on the RGB board.

3. RIGHT EDGE: The right edge of the image should be adjusted so that the faint raster to the right of the image can not be seen. This may be accomplished by using the Right Horizontal Edge Blanking control (R-113), which is the control second from the rear of the projector, on the RGB board.

#### 7.7 BLUE ENHANCE ADJUSTMENT PROCEDURE

REQUIRED INPUT SIGNAL: NORMAL TTL SOURCE

SPECIAL REQUIREMENTS: BLUE ENHANCE SWITCH S-1 "ON"

A. The blue enhance control R-27, located on the TTL board, is normally set to maximum. The amount of blue enhance can be decreased by adjusting this control.

#### 7.8 ELECTRONIC FOCUS ADJUSTMENT PROCEDURE

REQUIRED TEST PATTERN: INTERNAL CROSSHATCH PATTERN

A. GREEN RASTER: Adjust the green focus control until the horizontal scan lines become sharp and clear. Continue adjusting the control until the scan lines become fuzzy. Now adjust the control in the opposite direction until the scan lines obtain optimum clarity.

B. RED and BLUE RASTERS: Same as green.

7.9 MASTER HORIZONTAL KEYSTONE ADJUSTMENT PROCEDURE: Ensure the registration switch is "OFF" and apply sync only, at the desired frequency, to the "SYNC" BNC connector. (Ensure that nothing is connected to the Red, Green, and Blue BNC connectors.)

With the Remote Control, select RGB Analog operation and increase brightness so that a raster can be observed on the screen. Turn "OFF" the Red and Blue CRTs. The outermost left and right vertical edges of the projected Green image must be parallel. If the edges are not parallel, perform the following procedure.

1. Remove the Top Cover. It is held on by two 1/4 turn fasteners on the sides of the projector near the rear.

- 2 Tilt up the Registration board which is across the rear of the projector. The boards under the Registration board are now exposed.

3. The Master Horizontal Keystone control is the rearmost control (R-33) on the HOT board (65151) located in the slot against the right side of the projector, when it is viewed from the rear. Adjust the Master Horizontal Keystone control until the left and right edges of the raster are parallel.

7.10 MASTER EAST/WEST PINCUSHION ADJUSTMENT PROCEDURE: Ensure the registration switch is "OFF" and apply sync only, at the desired frequency, to the "SYNC" BNC connector. (Ensure that nothing is connected to the Red, Green, and Blue BNC connectors.) With the Remote Control, select RGB Analog operation and increase brightness so that a raster can be observed on the screen. Turn "OFF" the Red and Blue CRTs. The outermost left and right vertical edges of the projected Green image must be straight. If the edges are not straight, perform the following procedure.

1. Remove the Top Cover. It is held on by two 1/4 turn fasteners on the sides of the projector near the rear.

- 2 Tilt up the Registration board which is across the rear of the projector. The boards under the Registration board are now exposed.

3. The Master Horizontal Pincushion control (R-36) is the control just forward of the rearmost control on the HOT board (65151) located in the slot against the right side of the projector, when it is viewed from the rear. Adjust the Master Horizontal Pincushion control until the left and right edges of the raster are straight.

7.11 RASTER SIZING/CENTERING PROCEDURE: Ensure the registration switch is "OFF" and apply sync only, at the desired frequency, to the "SYNC" BNC connector. (Ensure that nothing is connected to the Red, Green, and Blue BNC connectors.) With the Remote Control, select RGB Analog operation and increase brightness so that a raster can be observed on the green CRT. Turn "OFF" the Red and Blue CRTs. Look into the lens of the green CRT. The top and bottom of the raster should just touch the mask on the top

and bottom of the CRT face with no over scanning and the left and right edges of the raster should just touch the mask on the left and right edges of the CRT face with no over scanning. If these conditions have not been met, perform the following procedure.

1. Remove the Top Cover. It is held on by two 1/4 turn fasteners on the sides of the projector near the rear.

2 Tilt up the Registration board which is across the rear of the projector. The boards under the Registration board are now exposed.

3. Look into the green lens, if the raster is the correct size, but not centered correctly, use the centering rings which are located on the rear of the registration coil to center the raster. The two centering rings should be very close to 90° displaced when the raster is properly centered.

4. Connect a sync signal, at the desired frequency, to the "VIDEO IN" BNC connector and select the crosshatch pattern with the Remote Control.

5. Turn "ON" the Red image with the Red CRT Cut-off switch on the registration panel.

6. Turn up the brightness so that you can observe the Green and red crosshatch patterns on the screen.

7. Adjust the centering rings on the red CRT so that the center horizontal crosshatch line of the red image exactly overlays the center horizontal crosshatch line of the green image, without any overscanning of the raster. (Check for overscanning by looking into the red lens.)

8. Turn "ON" the Blue image with the Blue CRT Cut-off switch on the registration panel.

9. Turn up the brightness so that you can observe the Green and blue crosshatch patterns on the screen.

10. Adjust the centering rings on the blue CRT so that the center horizontal crosshatch line of the blue image exactly overlays the center horizontal crosshatch line of the green image, without any overscanning of the raster. (Check for overscanning by looking into the blue lens.)

11. Ensure the registration switch is "OFF" and apply sync only, at the desired frequency, to the "SYNC" BNC connector. (Ensure that nothing is connected to the Red, Green, and Blue BNC connectors.) With the Remote Control, select RGB Analog operation and increase brightness so that a raster can be observed on the green CRT. Turn "OFF" the Red and Blue CRTs.

12. To adjust the width of the green raster use the Master Horizontal Width control. The Master Horizontal Width control (R-10) is the front control on the HOT board (65151) located in the slot against the right side of the projector, when it is viewed from the rear. Look into the green lens and adjust the Master Horizontal Width control until the raster just touches the left and right edges of the CRT face mask.

13. To adjust the height of the green raster, first set the Master Vertical Centering control (R-40) to its center position, then use the Master Vertical Size control. The Master Vertical Centering control and the Master Vertical Size control (R-21) may be adjusted through a slot in the rear panel. (Refer to Figure 2 or 3) Look into the green lens and adjust The Master Vertical Size control until the top and bottom of the raster just touch the top and bottom of the CRT face mask.

14. Connect a sync signal, at the desired frequency, to the "VIDEO IN" BNC connector and select the crosshatch pattern with the Remote Control.

15. Turn "ON" the Red image with the Red CRT Cut-off switch on the registration panel.

16. Turn up the brightness so that you can observe the Green and red crosshatch patterns on the screen.

17. Adjust the Red Vertical Size control (R-58) until the center Red crosshatch line is exactly the same height as the center Blue crosshatch line. (Refer to Figure 2 or 3 for R-58 location.)

18. Lift up the Registration Amp. board (just forward of the registration bezel) and you will gain access to the three yoke interface boards (65179). On each of the boards is a control marked L-1. This is the width coil for the CRT it is mounted on.

19. Adjust the Red Width Coil until the center horizontal red crosshatch line is exactly the same length as the center green crosshatch line.

20. Turn "OFF" the Green image and turn "ON" the Blue image with the CRT Cut-off switches.

21. The Red and Blue rasters will be displayed. Adjust the Blue Vertical Size control (R-73) until the blue raster is exactly the same height as the Red raster. (Refer to Figure 2 or 3 for R-73 location.)

22. adjust the Blue Width Coil until the center blue crosshatch line is exactly the same length as the center green crosshatch line.

7.12 HORIZONTAL LINEARITY ADJUSTMENT PROCEDURE: Connect a sync signal of the desired frequency to the "Video IN" BNC connector.

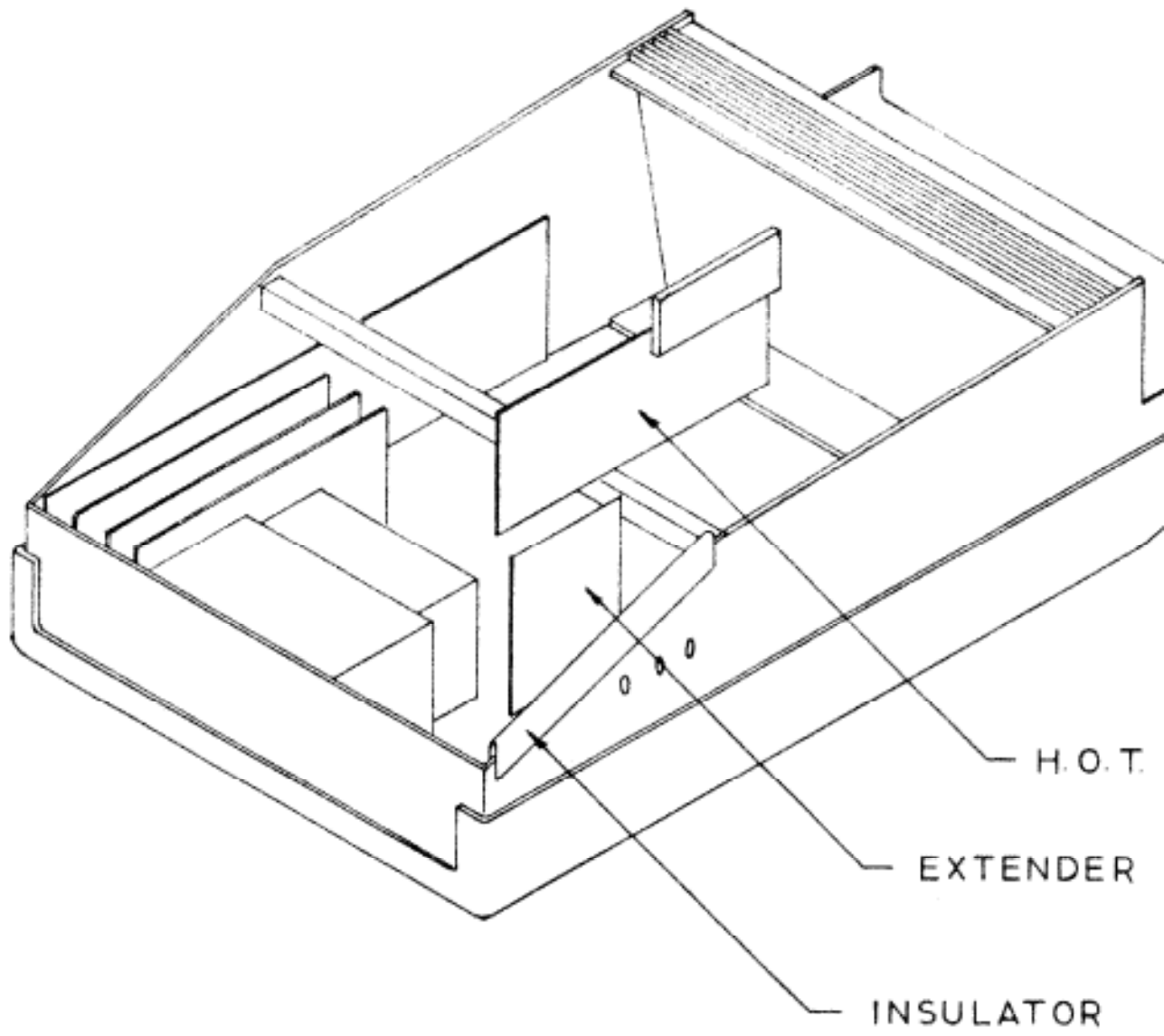

FIGURE 8



Select the internal crosshatch pattern with the red and blue rasters turned "OFF". Measure the horizontal width of a crosshatch box on the left side of the screen and compare it with the width of a crosshatch box on the right side of the screen. The width of the boxes throughout the image can not vary by more than 20%. If there is more than 20% variation, perform the following procedure.

1. Turn the projector "OFF" and disconnect the power cord.
2. Remove the Top Cover. It is held on by two 1/4 turn fasteners on the sides of the projector near the rear.
- 3 Tilt up the Registration board which is across the rear of the projector. The boards under the Registration board are now exposed.
4. Remove the three screws holding the HOT board (65151) to the right rear side of the projector. (Refer to Figure 8.)
5. Unplug the HOT board and reinstall it on the extender card (ESP Part No. 80643.) NOTE: The yoke cable assembly will still be connected to the HOT board.
6. Use fish-paper, cardboard, or other insulator as shown on Figure 8 to ensure against shorts between the HOT board and the chassis.
7. Reconnect the power cord, turn the projector "ON" and project the Green image on the screen.
8. The Horizontal Linearity control (SR-1) is located on the HOT board, just behind the Yoke Assembly cable plugged into J-55.
9. Use a nonmetallic hex tool and adjust the slug in SR-1 until there is no more than 20% difference in the width of the crosshatch boxes throughout the image. NOTE: Over adjustment of this control can cause the projector to shut down. If this should occur, back up slightly on the setting and the projector should reset itself.

7.13 VERTICAL LINEARITY ADJUSTMENT PROCEDURE: Connect a sync signal of the desired frequency to the "Video IN" BNC connector. Select the internal crosshatch pattern with the red and blue rasters turned "OFF". Measure the vertical height of a crosshatch box on the top of the screen and compare it with the height of a crosshatch box on the bottom of the screen. The height of the box can not vary by more than 20%. If this test is not met, perform the following procedure.

1. To adjust the vertical linearity of the green raster use the Vertical Linearity control. The Vertical Linearity control (R-21) may be adjusted through a slot in the rear panel. (Refer

to Figure 2 or 3) Adjust the The Vertical Linearity control until the Height of the boxes throughout the screen do not vary by more than 20%.

## Chapter 8

### SYSTEM TROUBLESHOOTING

#### 8.1 PREVENTATIVE MAINTENANCE

The only routine maintenance that needs to be performed, under normal usage, is the replacement of the alkaline battery in the Infrared Remote Control every six months. For very heavy usage of the remote control the battery may need to be changed more often. In areas of heavy dust, smoke, or other environmental contaminants, the unit should be cleaned internally by an ESP authorized service technician.

#### 8.2 SYSTEM TROUBLESHOOTING

This section of the manual describes the steps for correcting difficulties that may be encountered when using this projection system. If you should encounter a problem, locate it in the text below and follow the steps outlined for its correction. If you are still unable to correct the problem, service should be referred to a qualified service technician.

##### 8.2.1 SYSTEM WILL NOT OPERATE. (check steps in sequence)

1. Verify that the power cord is firmly plugged in at both ends.
2. Verify that power outlet is active.
3. Verify that the MASTER ON/OFF rocker switch on the rear of the unit is in the ON position. (Red "O" not visible)
4. If the MASTER ON/OFF rocker switch is in the ON position, and the LCD display did not give the message "ESP MODEL 300" or "ESP MODEL 500" as the case may be, check the main power fuse inside the door above the input power cord.
5. If the fuse is good and the message still has not been displayed, repeat steps 1 through 4 before contacting your ESP approved service technician.,
6. Make sure the remote control or receiver is properly connected, the remote control battery is good, and the ON button has been depressed. When this is done the POWER ON INDICATOR light above the rear fan should become illuminated, the fan should start running, and the LCD display should give the message "STATUS OK" and then display the mode of operation.

7. If the POWER ON INDICATOR is illuminated, insure that you have an active video signal (of the proper type) applied to the projector. The LCD display should tell you what the active mode of operation is.

NOTE

A SYNC SIGNAL IS REQUIRED IN ANY MODE OF OPERATION, INCLUDING TEST.

8. If there is still no projected image, an ESP approved service technician should be consulted.

### 8.3 EXCHANGE POLICY

Repair of the Esprit modular designed projectors shall be accomplished exclusively through a factory subassembly module exchange program. Servicing by an ESP Service Center or by an ESP selling dealer, is limited to failure diagnostics, registration alignment, and replacement of CRT assemblies, lenses, and subassembly modules.

No material and/or labor credit will be granted for an exchange subassembly, if it has been repaired, reworked or modified. The warranty will be voided if a repair, rework and/or modification of a subassembly module is performed other than by ESP.

## Chapter 9

### DIAGNOSTICS

#### 9.1 GENERAL

The ESPRIT 300 has sixteen internal LED indicators for use by the service technician to aid in the rapid determination of the faulty circuit in case of any malfunction of the equipment.

The ESPRIT 500 has a set of diagnostic messages which are displayed on the large LCD readout to provide information about the projector in case of a malfunction.

#### 9.2 DIAGNOSTIC MESSAGES (ESPRIT 500 ONLY)

When the projector is connected to an active AC source and the rocker switch on the rear panel is turned on, the LCD will display "ESP MODEL 500". When the "ON" button on the remote control is depressed, the projector LCD readout will display the message "STATUS OK" if there are no malfunctions. If there is a malfunction of the equipment the projector will display an error message. An example of the sequence of messages you would get if the -20V rail was missing is as follows. After the "ON" button on the remote control is depressed, the first readout would be -20V missing. A short time later the LCD readout would show the message "about to retry". A short time later the display would show "CALL DEALER".

The diagnostic readouts are designed to give you the proper message to expedite the repair of your projector.

#### 9.3 EARLY PRODUCTION ESPRIT 500 DIAGNOSTICS

In the early production Esprit 500 projectors, the diagnostics are not displayed on the LCD indicator. The diagnostics are available internally on sixteen led indicators. Eight of the led indicators are green and eight of the indicators are red.

All sixteen of the LED indicators are mounted in a row on the CPU board which is located against the left side of the projector, when viewed from the rear. The eight red LED indicators are on the end which is toward the lenses and the eight green LED indicators are on the end toward the rear.

The green LEDs are all rails and the red LEDs are function fault indicators.

The function or rail that the LED indicates is on the PCB beside the LED.

To gain access to the LED indicators, follow the steps listed below.

1. Remove the Top Cover. It is held on by two 1/4 turn fasteners on the sides of the projector near the rear.

2. Tilt up the Registration board which is across the rear of the

projector. The boards under the Registration board are now exposed.

The green LEDs are normally illuminated and if they are "OFF" it indicates a fault

The red LEDs are normally not illuminated and if they are illuminated it means a fault.

With the exceptions listed below, all of the green LEDs will be "ON" and all of the red LEDs will be "OFF", in a working projector.

1. When the projector is in any mode and no signal source is applied to the projector, the red SC, H. SYNC, and V. SYNC LEDs will be illuminated.
2. When the projector is in the test mode and no sync signal is applied to the "Video In" BNC connector, the red SC, H. SYNC, and V. SYNC LEDs will be illuminated.
3. When the projector is in standby mode, the red G-2 LED will be illuminated.

## Chapter 10

### RS-232 INTERFACE DATA

#### 10.1 GENERAL

Contact ESP Technical Service Department for Special application instructions if you desire to control your projector with RS-232.

## GLOSSARY

- Autolock: The capability of sensing the incoming Sync signal and automatically changing the scan rates to match the sync signal.
- Full duplex: A condition where communications is established, between two or more devices, in both directions.
- Grey scale The tracking of shades of grey from black to white.
- Hot spots: A red, green, and/or blue area observed on the screen when using rear screen projection since rear screen materials are not completely opaque and direct light from the CRT can be observed.
- On-axis projection: When the CRT's are perpendicular to the center of the screen. Since there is a mechanical 7° offset built into the projector, table mounting will be when the projector is at a 7° offset from on-axis projection.
- Optical wedges: Special wedge shaped lenses designed to reduce the effects of vignetting produced by parallel CRT projection.
- Threshold of visibility: The brightness condition where, while still visible, any decrease in the image brightness would cause it to no longer be visible.
- Throw distance: The distance between the lens and the screen, when the image is in focus.



MOTOROLA S1 FORMAT is a trademark of Motorola Semiconductor Products Inc.

IBM PC is a trademark of International Business Machines Corporation

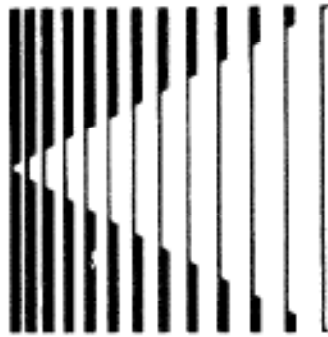

**ELECTRONIC  
SYSTEMS  
PRODUCTS™**

1301 ARMSTRONG DRIVE  
TITUSVILLE, FL 32780

**305/269-6680**