

BARCO CINE
9

R9002400

INSTALLATION MANUAL

BARCO

BARCO PROJECTION SYSTEMS

BARCO CINE
9

R9002400

INSTALLATION MANUAL

Date :
26032002

Rev. :
02

Art. No. :
R5976195

Due to constant research, the information in this manual is subject to change without notice.

Produced by BARCO NV, March 2002.
All rights reserved.

Trademarks are the rights of their respective owners.

BARCO n.v./Projection Systems

Noordlaan 5

B-8520 Kuurne

Belgium

Tel : +32/56/368211

Fax : +32/56/351651

E-mail : sales.bps@barco.com

Visite Barco at the web : <http://www.barco.com>

Printed in Belgium



TABLE OF CONTENTS

SAFETY INSTRUCTIONS	1-1
Safety Instructions	1-1
Notice on Safety	1-1
installation INSTRUCTIONS	1-1
OWNER'S RECORD	1-1
Safety indication on the product	1-1
Safety Warning	1-2
FEDERAL COMMUNICATION COMMISSION (FCC STATEMENT)	1-2
On Safety	1-2
Caution on Fire Hazard	1-3
On installation	1-3
On servicing	1-3
On cleaning	1-3
On repacking	1-4
On illumination	1-4
PACKING AND DIMENSIONS	2-1
Unpacking	2-1
Unpacking	2-1
Contents of the shipping carton	2-1
Projector dimensions (in mm)	2-2
INSTALLATION GUIDELINES	3-1
Installation Guidelines	3-1
Ambient Temperature Conditions	3-1
Humidity Conditions	3-1
Environment	3-1
Environment condition check	3-1
Ambient light	3-1
Which screen type?	3-2
Image sizing	3-2
Projector Configuration	3-3
Which configuration can be used.	3-3
Positioning the Projector	3-3
Lens formulas	3-4
Battery installation in the RCU.	3-4
How are the batteries delivered ?	3-4
How to install ?	3-4
INSTALLATION SETUP	4-1
Access to Controls	4-1
Warning	4-1
Opening the top cover	4-1
Removing the top cover	4-2
Reinstalling the top cover	4-2
Scan Adaptation	4-3
Scan Connectors	4-3
Location of the connectors	4-3
Access to the connectors	4-3
Horizontal Scan connectors	4-4
Vertical Scan connectors	4-4
Scan connector settings	4-4
AC POWER CONNECTIONS	5-1
AC Power cord	5-1
AC Power Cord Connection	5-1
Preparing the power cord	5-1
AC Power	5-2
The power voltage	5-2
Fuses	5-2
Switching on the projector	5-3
Switching on	5-3
Switching off	5-3
Start up in Operational Mode	5-3
Start up in Stand by Mode	5-4
Stationary Image Warning	5-4

SOURCE CONNECTIONS	6-1
Input Sources	6-1
Input facilities	6-1
Connecting a Composite Video source to Port 1	6-2
Connecting a S-Video (or Composite Video) source to Port 2	6-2
Connecting a RGB Analog source to Port 3	6-4
Connecting a RGB Analog source to Port 4/5	6-6
Connecting a Component Video source to Port 4/5	6-6
Connecting a RGB Analog source with Tri-level sync to Port 4/5	6-7
Connecting a Component Video source with Tri-level sync to Port 4/5	6-7
Communication connections	6-8
Communication facilities :	6-8
Peripheral types	6-8
Connecting a RCVDS 05 source selector	6-8
Connecting a VS05 source selector	6-8
Connecting an IR Remote Receiver 800	6-8
INSTALLATION ADJUSTMENT MODE	7-1
Installation adjustment mode	7-1
Access to Installation Adjustment Mode	7-1
Password Protection	7-1
Entering the password	7-1
Remark	7-1
Overview flowchart of the installation Adjustment mode	7-2
Projector Distance	7-3
Optical Lens Focusing	7-4
Raster centering	7-5
CRT Projection Angle Adjustment	7-6
Scheimpflug Adjustment (Diagonal image focusing)	7-7
MESSAGES, WARNINGS AND FAILURES	8-1
BARCO CEILING MOUNT SUPPORT	A-1
Introduction	A-1
Contents of the installation guidelines	A-1
GAMMA CORRECTIONS	B-1
Gamma corrections	B-1
Gamma warning	B-1
Procedure for Gamma corrections	B-1

1

SAFETY INSTRUCTIONS**Safety Instructions*****Notice on Safety***

This equipment is built in accordance with the requirements of the international safety standards EN60950, UL 1950 and CSA C22.2 No.950, which are the safety standards of information technology equipment including electrical business equipment.

These safety standards impose important requirements on the use of safety critical components, materials and isolation, in order to protect the user or operator against risk of electric shock and energy hazard, and having access to live parts. Safety standards also impose limits to the internal and external temperature rises, radiation levels, mechanical stability and strength, enclosure construction and protection against the risk of fire.

Simulated single fault condition testing ensures the safety of the equipment to the user even when the equipment's normal operation fails.

INSTALLATION INSTRUCTIONS

Before operating this equipment please read this manual thoroughly, and retain it for future reference.

Installation and preliminary adjustments should be performed by qualified BARCO personnel or by authorized BARCO service dealers.

OWNER'S RECORD

The part number and serial number are located at the back side of the projector. Record these numbers in the spaces provided below. Refer to them whenever you call upon your BARCO dealer regarding this product.

PART NUMBER :

SER. NUMBER :

DEALER :

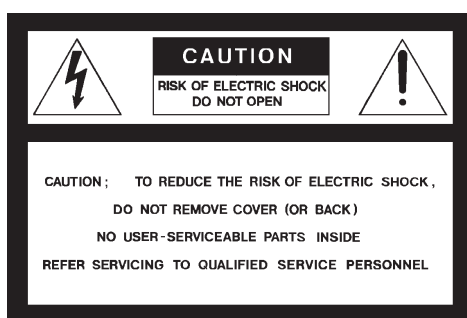
Safety indication on the product

The lightning flash with an arrowhead within a triangle is intended to tell the user that parts inside this product may cause a risk of electrical shock to persons.



The exclamation point within a triangle is intended to tell the user that important operating and/or servicing instructions are included in the technical documentation for this equipment.

Safety Warning

TOPREVENT FIRE OR ELECTRICAL SHOCK HAZARD, DO NOT EXPOSE THIS EQUIPMENT TO RAIN OR MOISTURE

FEDERAL COMMUNICATION COMMISSION (FCC STATEMENT)

This equipment has been tested and found to comply with the limits of a class A digital device, pursuant to Part 15 of the FCC Rules. These limits are designed to provide reasonable protection against harmful interference when the equipment is operated in a commercial environment. This equipment generates, uses and can radiate radio frequency energy and, if not installed and used in accordance with the instruction manual, may cause harmful interference to radio communications. Operation of this equipment in a residential area is likely to cause harmful interference in which case the user will be required to correct the interference at his own expense.

Note :

The use of shielded cables is required to comply within the limits of Part 15 of FCC rules and EN55022.

- * All the safety and operating instructions should be read before using this unit.
- * The safety and operating instructions manual should be retained for future reference.
- * All warnings on the equipment and in the documentation manuals should be adhered to.
- * All instructions for operating and use of this equipment must be followed precisely.

On Safety

1. This product should be operated from an AC power source.
Power input is autoranging from 100 V (-10%) to 240V (+6%).
2. All equipment in the system is equipped with a 3-wire grounding plug, a plug having a third (grounding) pin. This plug will only fit into a grounding-type power outlet. This is a safety feature. If you are unable to insert the plug into the outlet, contact your electrician to replace your obsolete outlet. Do not defeat the purpose of the grounding-type plug.

WARNING FOR THE CUSTOMERS: THIS APPARATUS MUST BE GROUNDED (EARTHED) via the supplied 3 conductor AC power cable. (If the supplied power cable is not the correct one, consult your dealer.)

A. Mains lead (Power cord) with CEE 7 plug:

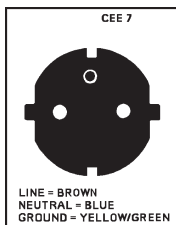

The wires of the mains lead are colored in accordance with the following code.

Green and yellow: earth (safety earth)
Blue: neutral
Brown: line (live)

B. Power cord with ANSI 73.11 plug:

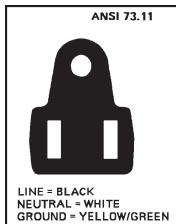

The wires of the power cord are colored in accordance with the following code.

Green/yellow: ground
White: neutral
Black: line (live)

3. Do not allow anything to rest on the power cord. Do not locate this product where persons will walk on the cord. To disconnect the cord, pull it out by the plug. Never pull the cord itself.
4. If an extension cord is used with this product, make sure that the total of the ampere ratings on the products plugged into the extension cord does not exceed the extension cord ampere rating.
5. Never push objects of any kind into this product through cabinet slots as they may touch dangerous voltage points or short out parts that could result in a risk of fire or electrical shock.

Never spill liquid of any kind on the product. Should any liquid or solid object fall into the cabinet, unplug the set and have it checked by qualified service personnel before resuming operations.

6. Lightning - For added protection for this video product during a lightning storm, or when it is left unattended and unused for long periods of time, unplug it from the wall outlet. This will prevent damage to the projector due to lightning and AC power-line surges.

Caution on Fire Hazard

Do not place flammable or combustible materials near projector !

BARCO large screen projection products are designed and manufactured to meet the most stringent safety regulations. This projector radiates heat on its external surfaces and from ventilation ducts during normal operation, which is both normal and safe.

Explosing flammable or combustible materials into close proximity of this projector could result in the spontaneous ignition of that material, resulting in a fire. For this reason, it is absolutely necessary to leave an "exclusion zone" around all external surfaces of the projector whereby no flammable or combustible materials are present. The exclusion zone must be not less than 10 cm (4") for Barco Retro Projectors. Do not cover the projector with any material while the projector is in operation.

Keep flammable and combustible materials away from the projector at all times. Mount the projector in a well ventilated area away from sources of ignition and out of direct sun light. Never expose the projector to rain or excessive moisture. In the event of fire, use sand, CO₂, or dry powder fire extinguishers; never use water on an electrical fire.

Always have service performed on this projector by authorized BARCO service personnel. Always insist on genuine BARCO replacement parts. Never use non-BARCO replacement parts as they may degrade the safety of this projector.

On installation

1. Do not place this equipment on an unstable cart, stand, or table. The product may fall, causing serious damage to it.
2. Do not use this equipment near water.
3. Slots and openings in the cabinet and the back or bottom are provided for ventilation; to ensure reliable operation of the product and to protect it from overheating, these openings must not be blocked or covered. The openings should never be blocked by placing the product on a bed, sofa, rug, or other similar surface. This product should never be placed near or over a radiator or heat register.

The projector should not be placed in a built-in installation or enclosure unless proper ventilation is provided.

4. Do not block the projector cooling fans or free air movement under and around the projector. Loose papers or other objects may not be nearer to the projector than 4" on any side.

On servicing

Do not attempt to service this product yourself, as opening or removing covers may expose you to dangerous voltage potentials and risk of electric shock!

Refer all servicing to qualified service personnel.

Unplug this product from the wall outlet and refer servicing to qualified service personnel under the following conditions:

- a. When the power cord or plug is damaged or frayed.
- b. If liquid has been spilled into the equipment.
- c. If the product has been exposed to rain or water.
- d. If the product does not operate normally when the operating instructions are followed.

Note : Adjust only those controls that are covered by the operating instructions since improper adjustment of the other controls may result in damage and will often require extensive work by a qualified technician to restore the product to normal operation.

- e. If the product has been dropped or the cabinet has been damaged.
- f. If the product exhibits a distinct change in performance, indicating a need for service.

Replacement parts - When replacement parts are required, be sure the service technician has used original BARCO replacement parts or authorized replacement parts which have the same characteristics as the BARCO original part. Unauthorized substitutions may result in degraded performance and reliability, fire, electric shock or other hazards. Unauthorized substitutions may void warranty.

Safety check - Upon completion of any service or repairs to this projector, ask the service technician to perform safety checks to determine that the product is in proper operating condition.

On cleaning

Unplug this product from the wall outlet before cleaning. Do not use liquid cleaners or aerosol cleaners. Use a damp cloth for cleaning.

- To keep the cabinet looking brand-new, periodically clean it with a soft cloth. Stubborn stains may be removed with a cloth lightly dampened with mild detergent solution. Never use strong solvents, such as thinner or benzene, or abrasive cleaners, since these will damage the cabinet.
- To ensure the highest optical performance and resolution, the projection lenses are specially treated with an anti-reflective coating, therefore, avoid touching the lens. To remove dust on the lens, use a soft dry cloth. Do not use a damp cloth, detergent solution, or thinner.

On repacking

Save the original shipping carton and packing material; they will come in handy if you ever have to ship your equipment. For maximum protection, repack your set as it was originally packed at the factory.

On illumination

In order to obtain the best quality for the projected image, it is essential that the ambient light which is allowed to fall on the screen be kept to an absolute minimum.

When installing the projector and screen, care must be taken to avoid exposure to ambient light directly on the screen. Avoid adverse illumination on the screen from direct sunlight or fluorescent lighting fixtures.

The use of controlled ambient lighting, such as incandescent spot light or a dimmer, is recommended for proper room illumination. Where possible, care should also be taken to ensure that the floors and walls of the room in which the projector is to be installed are non-reflecting, dark surfaces. Brighter surfaces will tend to reflect and diffuse the ambient light and hence reduce the contrast of the projected image on the screen.

Note

Definition

Service personnel: Persons having appropriate technical training and experience necessary to be aware of hazards to which they are exposed in performing a task and of measures to minimize the danger to themselves or other persons.

2

PACKING AND DIMENSIONS

Unpacking

Unpacking

To open the banding around the carton, pull out the clip as shown below :

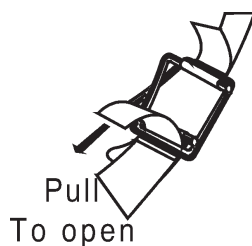

Take the projector out of its shipping carton.

Be aware of the weight of the projector : 85 kg (188 lbs).

To carry the projector, 2 persons are needed.

The projector is fixed on a wooden plate with 4 M6 screws.

Hint

Save the original shipping carton and packing material, which will come in handy if you ever have to ship your projector. For maximum protection, repack your projector as it was originally packed at the factory.

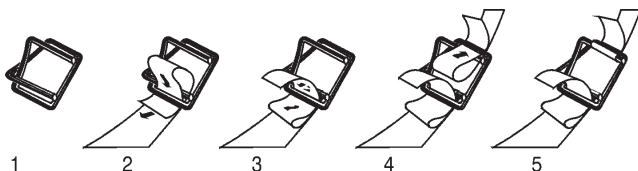

Contents of the shipping carton

- 1 BARCO CINE 9 projector
- 1 Remote Control Unit plus 2 batteries (1.5V)
- 1 Power cord with outlet plug type CEE7 or ANSI 73.11
- 1 Owner's Manual
- 1 Installation Manual

Projector dimensions (in mm)

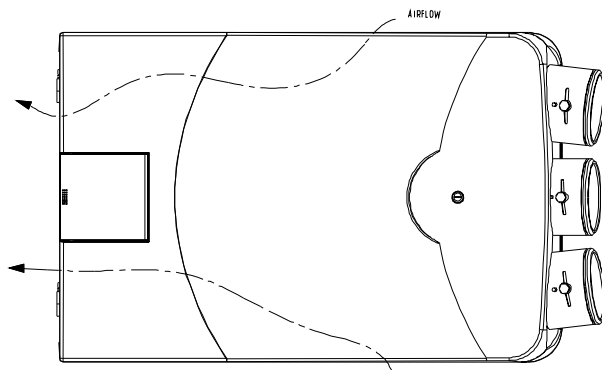
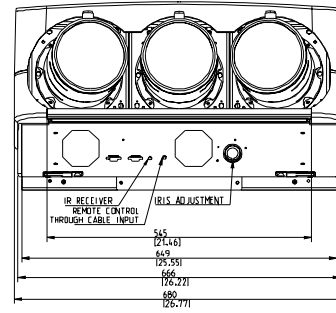
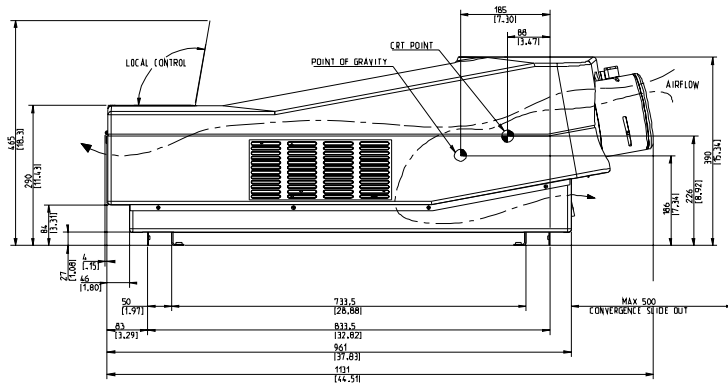

3

INSTALLATION GUIDELINES

Installation Guidelines

Ambient Temperature Conditions

Careful consideration of things such as image size, ambient light level, projector placement and type of screen to use are critical to the optimum use of the projection system.

Operation temperature :

Max. ambient temperature : 40 °C (104°F)

Min. ambient temperature : 0 °C (32°F).

The projector will not operate if ambient air temperature falls outside this range (0°C- 40°C) (32°F-104°F).

Storage temperature : -35 °C to + 65 °C (-25.6°F to 149°F)

Humidity Conditions

Storage : 0 - 98% RH Non-condensing

Operation : 0 - 95% RH Non-condensing

Environment

Do not install the projection system in a site near heat sources such as radiators or air ducts, or in a place subject to direct sunlight, excessive dust or humidity. Be aware that room heat rises to the ceiling; check that temperature near the installation site is not excessive.

Environment condition check

Warning: Harmful Environmental Contamination Precaution

A projector must always be mounted in a manner which ensures the free flow of *clean air* into the projectors ventilation inlets. For installations in environments where the projector is subject to airborne contaminants such as that produced by smoke machines or similar (these deposit a thin layer of greasy residue upon the projectors internal optics and imaging electronic surfaces, degrading performance), then it is highly advisable and desirable to have this contamination removed prior to it reaching the projectors clean air supply. Devices or structures to extract or shield contaminated air *well away* from the projector are a prerequisite, if this is not a feasible solution then measures to relocate the projector to a clean air environment should be considered.

Only ever use the manufactures recommended cleaning kit which has been specifically designed for cleaning optical parts, never use industrial strength cleaners on a projectors optics as these will degrade optical coatings and damage sensitive optoelectronic components. Failure to take suitable precautions to protect the projector from the effects of persistent and prolonged air contaminants will culminate in extensive and irreversible ingrained optical damage. At this stage cleaning of the internal optical units will be non-effective and impracticable. Damage of this nature is under no circumstances covered under the manufactures warranty and may deem the warranty null and void. In such a case the client shall be held solely responsible for all costs incurred during any repair. It is the clients responsibility to ensure at all times that the projector is protected from the harmful effects of hostile airborne particles in the environment of the projector. The manufacture reserves the right to refuse repair if a projector has been subject to wantful neglect, abandon or improper use.

Ambient light

The ambient light level of any room is made up of direct or indirect sunlight and the light fixtures in the room. The amount of ambient light will determine how bright the image will appear. So, avoid direct light on the screen as much as possible.

Windows that face the screen should be covered by opaque drapery while the set is being viewed. It is desirable to install the projecting system in a room whose walls and floor are of non-reflecting material. The use of recessed ceiling lights and a method of dimming those lights to an acceptable level is also important. Too much ambient light results in a 'wash out' of the projected image. This appears as less contrast between the darkest and lightest parts of the image. With bigger screens, the 'wash out' becomes more important. As a general rule, darken the room to the point where there is just sufficient light to read or write comfortably. Spot lighting is desirable for illuminating small areas so that interference with the screen is minimal.

Which screen type?

There are two major categories of screens used for projection equipment. Those used for front projected images and those for rear projection applications.

Screens are rated by how much light they reflect (or transmit in the case of rear projection systems) given a determined amount of light projected toward them. The 'GAIN' of a screen is the term used. Front and rear screens are both rated in terms of gain. The gain of screens range from a white matte screen with a gain of 1 (x1) to a brushed aluminized screen with a gain of 10 (x10) or more. The choice between higher and lower gain screens is largely a matter of personal preference and another consideration called the Viewing angle.

In considering the type of screen to choose, determine where the viewers will be located and go for the highest gain screen possible. A high gain screen will provide a brighter picture but reduce the viewing angle.

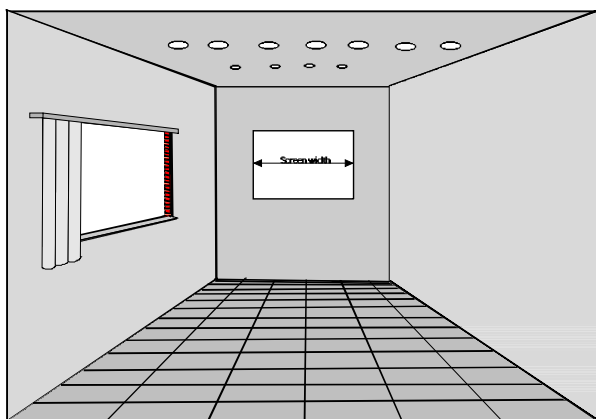

Image sizing

The projector is designed for projecting an image width from 1.4m (4.6') to 6m (20') with an aspect ratio of 4 to 3. It leaves the BARCO factory, adjusted as a ceiling/front projector for a screen width of 2.4m (7.8'). Changing the image size from the factory preset size requires a realignment of the projector.

Projector Configuration

Which configuration can be used.

The projector can be installed to project images in four different configurations (image 1):

- rear/ceiling,
- rear/table,
- front/ceiling or
- front/table.

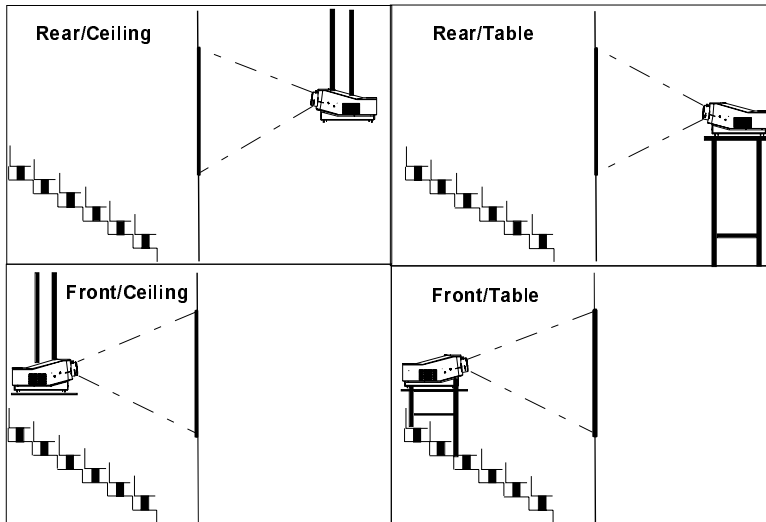
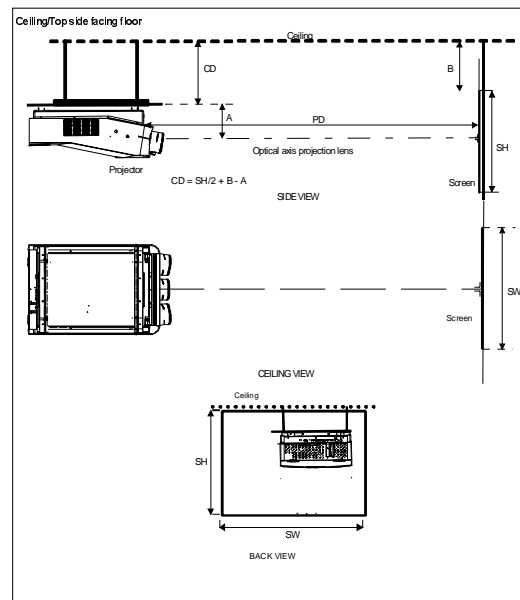
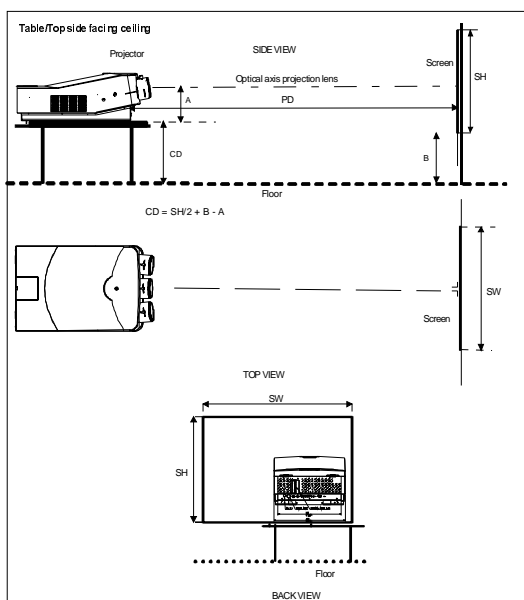

image 1

Positioning the Projector

The projector should be installed perpendicular with the screen on a distance PD and water leveled in both directions. The mounting positions shown in following images are shown for a nominal lens position.



Definitions of the Abbreviation on drawings

- B = Distance between ceiling and top of the screen or between floor and bottom of the screen.
- A = Distance from the middle of the lens (in nominal position) to bottom side of the projector.
- CD = Total distance between projector and ceiling or projector and floor.
- SW = Screen width.
- SH = Screen height (image height).
- PD = Projector Distance, distance between screen and projector.

Lens formulas

Following lens formulas should be used to calculate the ideal projection distance:

In metric:

$$PD[m] = 1.311 \times SW[m] + 0.33$$

$$A[cm] = 11.3 \times SW[m] - 28.188$$

In inch:

$$PD[inch] = 1.311 \times SW[inch] + 13.029$$

$$A[inch] = 0.113 \times SW[inch] - 11.098$$

Battery installation in the RCU.

How are the batteries delivered ?

Two batteries are packed together with the power cord. Before using your RCU, install first these batteries.

How to install ?

- 1 Remove the battery cover on the backside by pushing the handle a little towards the bottom of the RCU (Image 1).
- 2 Lift up the top side of the cover at the same time (Image 1).
- 3 Insert the batteries as indicated in the RCU (Image 2).
- 4 Put the battery cover on its place.

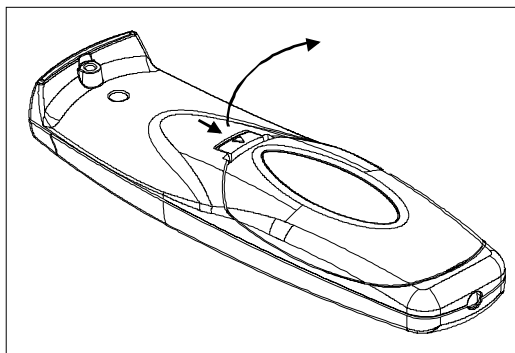

Image 1

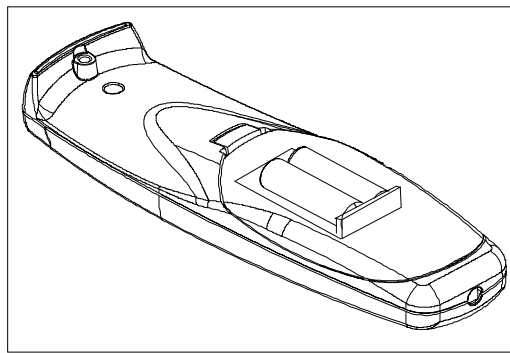

Image 2

4

INSTALLATION SETUP

Access to Controls

Warning

Risk of electric shock !

The installation should only be done by BARCO authorized service personnel

Opening the top cover

During the projector setup and installation it is necessary to open the top cover. Follow the procedure described below :

- 1 Turn the locking screw with a screwdriver counter clockwise (Image 1).



Image1

- 2 Lift up and pivot the top cover backwards (Image 2).



Image2

Caution:

The projector's top cover is **not** supported with locking hinge. Open with care and support the cover with your hand.

Removing the top cover

During some installations, it will be convenient to remove the top cover from the projector totally.
Proceed as follows :

- 1 Disengage the left axis A (Image 1) by pulling it out of the hinge.

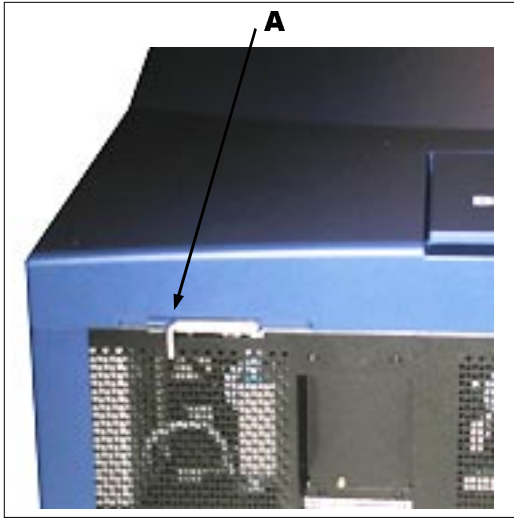

Image 1

- 2 Proceed the same way for the right axis.
- 3 The top cover being disengaged it can now be lifted up from the projector.

Reinstalling the top cover

To reinstall the top cover on the projector :

- 1 Place the top cover back on the projector.
- 2 Bring the two parts of the hinges right in front of each other (Image 2).
- 3 Insert the handles back in the hinges.
- 4 Secure the locking screw by turning it clockwise with a screwdriver.



Image2

Scan Adaptation

Scan Connectors

The scan connectors must be placed in the correct position which corresponds to the desired scanning configuration. To change the scanning, it is necessary to remove the projector top cover and to open the protection plate. For opening the projector's top cover, see 'Access to controls'.

Warning

Turn off the projector and unplug the power cord before changing the scan direction.

Location of the connectors

The 6 scan connectors are located on the frontside (CRT side) of the main frame.

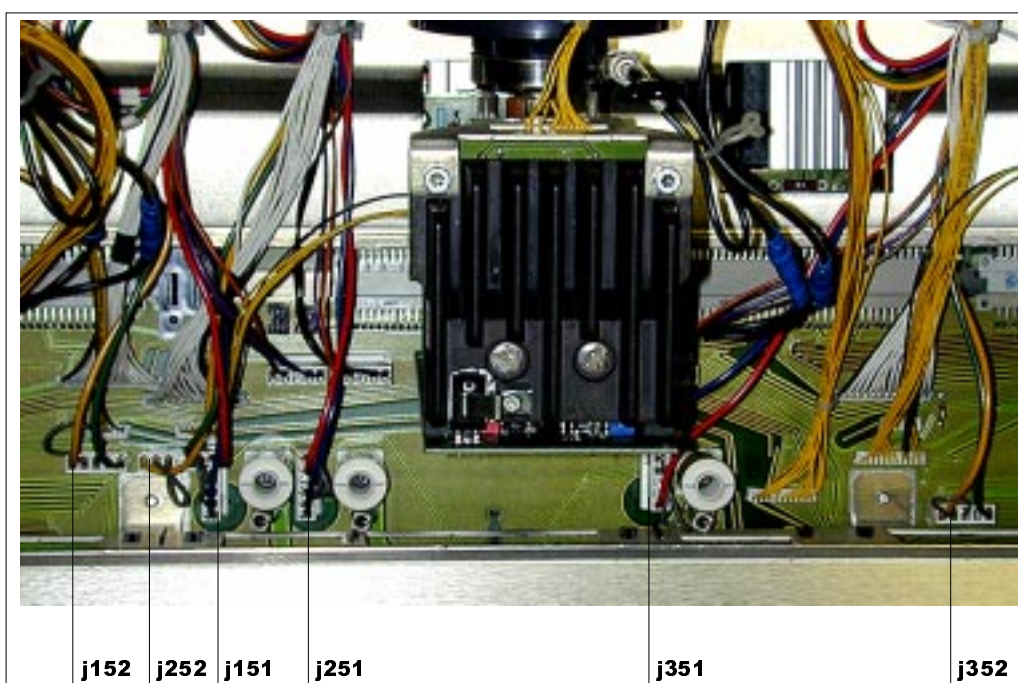

Access to the connectors

- 1 Open the top cover and remove it from the projector (see 'Removing top cover');
- 2 Loosen the 3 retaining screws on each side of the projector (Image 1);
- 3 Open the protection plate and pivot it forward (toward lenses) (Image 2).

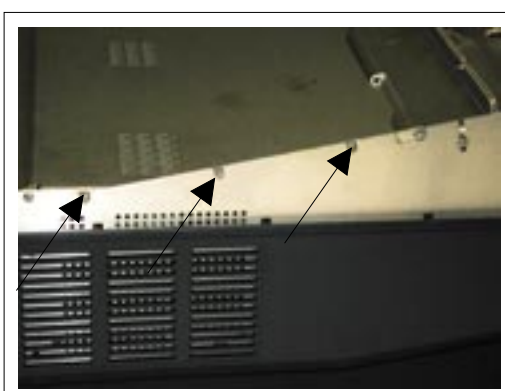

Image 1

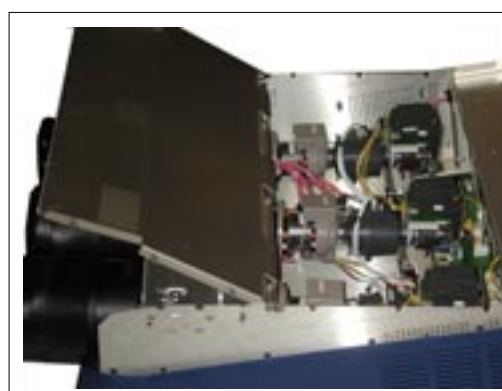

Image 2

Horizontal Scan connectors

When changing the horizontal scan, insure that all three connectors are set in the same position.
The configuration of each connector is depending on its orientation i.e. on the position of the strap (grey wire).

Vertical Scan connectors

When changing the vertical scan, insure that all three connectors are set in the same position.
The configuration of each connector is depending on its orientation i.e. on the position of the (grey wire) strap A (Image 1) .

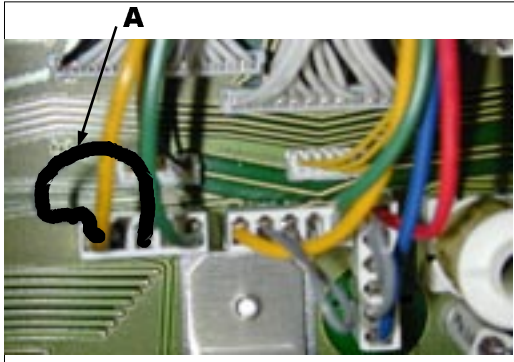
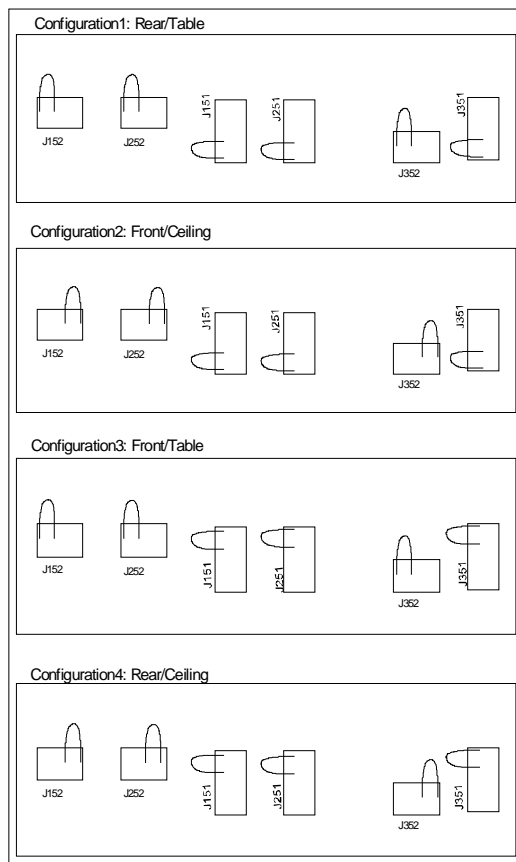

Image 1

Scan connector settings

The position of the scan connectors for the different mounting configurations can be summarized as follows:



- J151: Horizontal Red Scan Connector
- J251: Horizontal Green Scan Connector
- J351: Horizontal Bleu Scan Connector
- J152: Vertical Red Scan Connector
- J252: Vertical Green Scan Connector
- J352: Vertical Bleu Scan Connector

After setting the scan connectors, close the metal protection plate and secure it with the retaining screws. Close the top cover and lock it with the locking screw.

Scan position check

To check the scan position i.e. the orientation of the scan connectors proceed as follows:

This procedure can only be done after power (mains) connection. So, first continue with the projector setup and the connections and then return to this procedure.

- 1 Switch on the projector. The projector starts up on the last selected source.
- 2 Press **ADJUST**.
- 3 Highlight **SERVICE** by pushing the cursor key **↑** or **↓** (Menu 1).
- 4 Press **ENTER**: the 'SERVICE MODE MENU' will be displayed. (Menu 2)
- 5 Highlight 'PROJECTOR SET-UP' by pushing the cursor key **↑** or **↓** and press **ENTER**.
- 6 Push the cursor key **↑** or **↓** to highlight Identification (Menu 3).
- 7 Press **ENTER** to select.

The identification screen will be displayed (Menu 4).

This screen gives the current information about the projector configuration in the line entitled 'Config'.

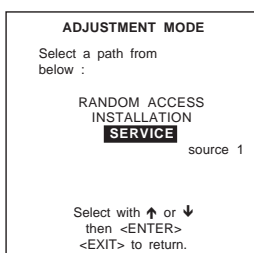

Menu 1

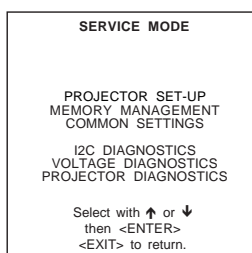

Menu 2

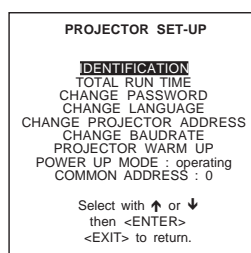

Menu 3



Menu 4

All projectors leave the factory set with a ceiling/front configuration.

5

AC POWER CONNECTIONS

AC Power cord

AC Power Cord Connection

Use the supplied power cord to connect your projector to the wall outlet. Plug the female power connector into the male connector at the rear side of the projector.

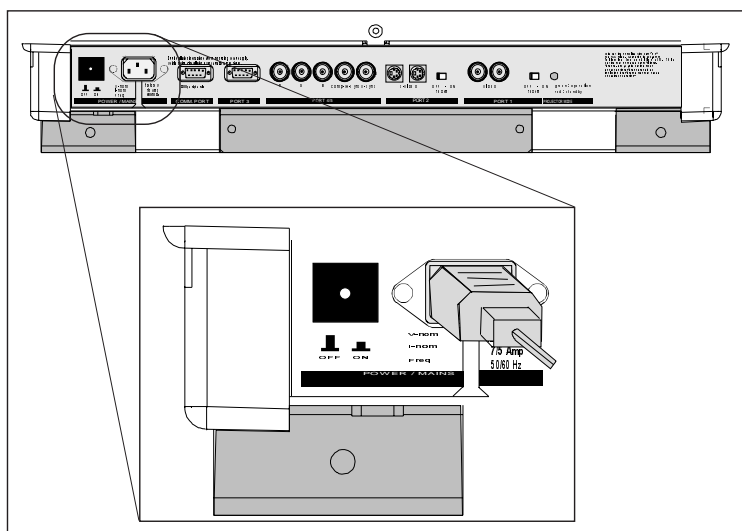
**Preparing the power cord****Power cord with CEE7 plug**

As the colors of the wires in the mains lead of this apparatus may not correspond with the colored markings identifying the terminals in your plug, proceed as follows:

- 1 The yellow/green wire is ground and must be connected to the terminal in the plug which is marked by the letter E or colored yellow and green.
- 2 The blue wire is neutral and must be connected to the terminal marked with the letter N or colored black.
- 3 The brown wire is the line and must be connected to the terminal marked with the letter L or colored red.

The wires of the delivered mains lead (power cord) are colored in accordance with the following code :

Yellow and Green	:	Ground (Earth).
Blue	:	Neutral.
Brown	:	Live.

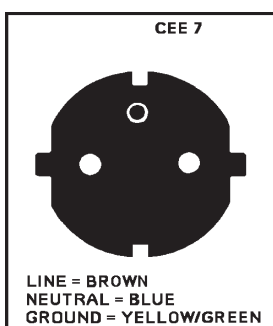

Power cord with an ANSI 73.11 plug

The wires of the delivered mains lead (power cord) are colored in accordance with the following code :

- Yellow and Green : Ground (Earth).
- White : Neutral.
- Black : Live.

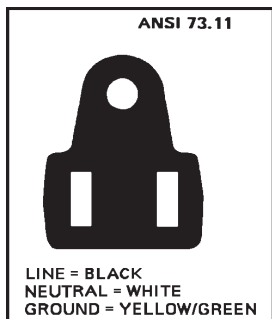

AC Power

The power voltage

The power input voltage is autoranging between 100V (-10%) and 240V (+6%)

Fuses

<u>Fuses</u>	<u>Order Number</u>
T10A (2x)	R314521
F10A (1x)	R314155

For continued protection against fire hazard :

- 1 Replace with the same type of fuse.
- 2 Refer replacement to qualified service personnel.

Switching on the projector

Switching on

The projector is switched ON and OFF using the power (mains)switch.

Pressed : ON

Not pressed : OFF

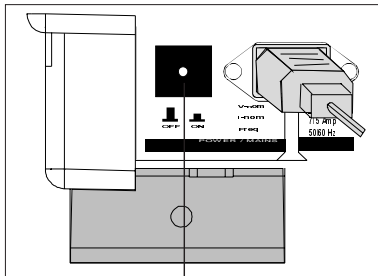

power switch

Stand by indication lamp :

No light up : projector switched off

Green color : projector in Operational mode

Red color : projector is in Standby mode.

When switching on with the power switch, the projector can start now in :

- 1 Operational mode (picture displayed)
- 2 Stand by mode

The way of start up depends on the 'Power up' setting in the service mode.

Switching off

Use the same power switch to switch off the projector

Start up in Operational Mode

The projector can start up with the selected source or
the projector can start up with a warm up cycle message (menu 1).

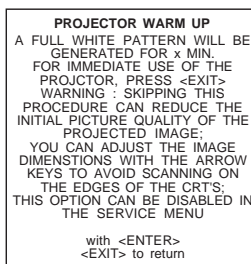

Menu 1

When this warm up cycle message appears on the screen, the menu offers the possibility to start with a x minutes taking warm up periode (press **ENTER**) or to skip this cycle (press **EXIT**). The x minutes and the horizontal frequency can be programmed in the 'Service mode' under the item 'Projector Set Up'.

Note : This warm up periode is built in so that the projector can reach its maximum specifications and minimize all distortions.

When starting this warm up period, a full white image is shifted on the CRT faceplate to avoid a burn in. Every 30 seconds a text box will be displayed on another place on the screen with the remaining time to go.

The image dimensions can be adjusted with the cursor keys to avoid scanning on the edges of the CRT's.

To interrupt the warm up period, handle as follow :

- 1 Press **EXIT**, the warm up menu will be redisplayed with the remaining time indication.
- 2 Press **EXIT** again to quit the warm up cycle and to display the source.

Start up in Stand by Mode

The projector starts up in stand by.

Press a digit key corresponding to the desired source or press STBY key.
The projector displays the selected source or the warm up cycle message.

When this warm up message appears on the screen, handle as described in 'Start up in Operational Mode'.

Stationary Image Warning

Do not display a stationary image with full brightness and contrast for longer than 20 min., otherwise you risk damage to the CRT's.

6

SOURCE CONNECTIONS

Input Sources

Input facilities

The following source types can be connected to the inputs :

- 1 Composite Video
- 2 S-Video
- 3 RGBS or RGsB
- 4 RGB3S or RG3sB
- 5 (R-Y)Y(B-Y)S or (R-Y)Ys(B-Y) [component input]
- 6 (R-Y)Y(B-Y)3S or (R-Y)Y3s(B-Y) [component input]

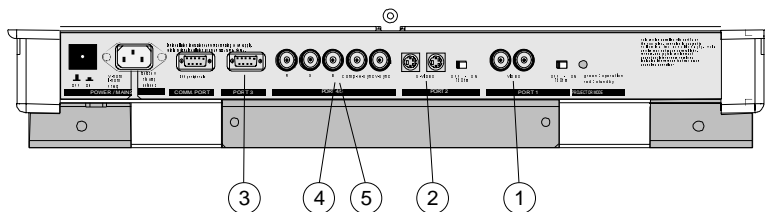

Source No	Projector input	Press digit button
1	Comp. Video	1
2	S-Video/Comp. Video	2
3	RGB	3
4/5	RGB	4 or 5
4/5	Component video	6
4/5	RGB with Tri level sync	7
4/5	Component video with Tri-level sync	8

Connecting a Composite Video source to Port 1

Composite video signals coming from a VCR, OFF air signal decoder and so on can be connected to Port 1.

75 Ω Termination Switch for Video

Terminate the video input of the projector using the 75 Ω switch next to the video input, when the projector operates alone or when the projector is the last unit in a loop-through configuration.

- The switch is set to "ON" : signal terminated.
- The switch is set to "OFF" : signal not terminated.

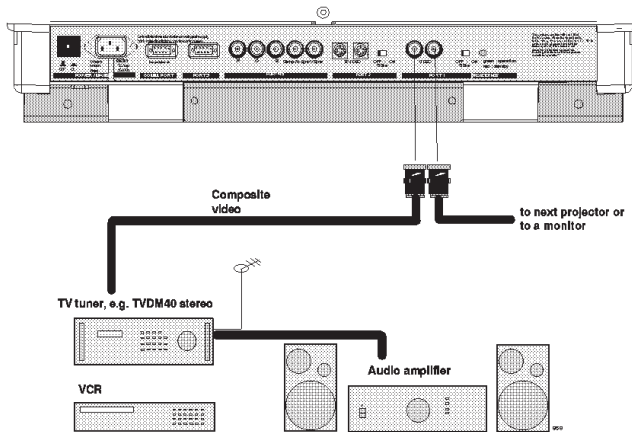

How to select Composite Video source:

Select the Composite Video source input by pressing the numeric button 1 on the RCU or the local keypad.

Connecting a S-Video (or Composite Video) source to Port 2

Separate Y-luma/C-chroma signals for higher quality playback of Super VHS signals can be connected to Port 2 . A composite video can also be connected to this port.

In case of using Port 2 for connecting the Composite Video, the selection of this source have to be done inside the "Picture Tuning" menu. Please refer to the Owner's Manual of this projector.

75 Ω Termination Switch for S-video

Terminate the S-video input of the projector using the 75 Ω switch next to the S-video input when the projector operates alone or when the projector is the last unit in a loop-through configuration.

- The switch is set to "ON" : signal terminated.
- The switch is set to "OFF" : signal not terminated.

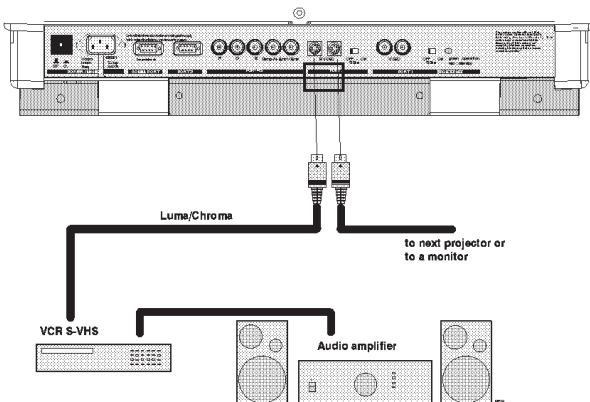

Pin assignment for the 4 pin connector

PIN	DESCRIPTION	CHARACTERISTIC
PIN 1	EARTH (GROUND) LUMINANCE	
PIN 2	EARTH (GROUND) CHROMINANCE	
PIN 3	LUMINANCE SIGNAL (Y)	1V_{pp} 3dB
PIN 4	CHROMINANCE SIGNAL (C)	300mV_{pp} 3dB

How to select S-Video (or composite Video) source:

Select the S-Video input by pressing the numeric button 2 on the RCU or the local keypad.

Connecting a RGB Analog source to Port 3

Connect a RGB Analog signal via an interface (e.g. RGB 120MHz interface, part number 98 26570) to Port 3: RGB analog input with automatic sync detection (Separate H and V sync inputs, with composite sync input or with sync signals on green).

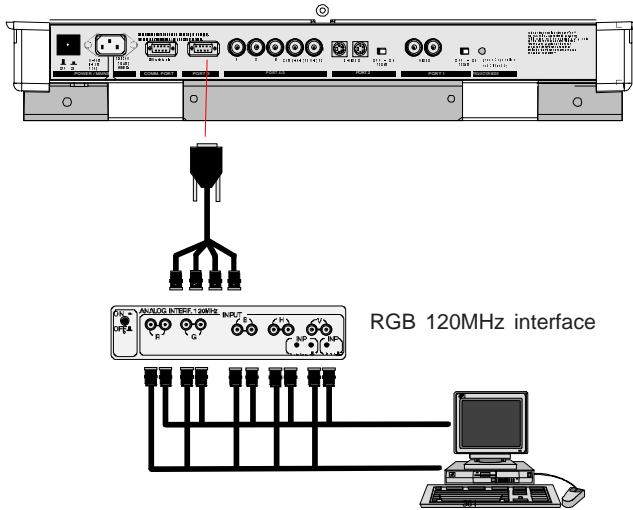

Pin assignment for the D9 (male) connector:

- 1 not connected
- 2 ground RGBS
- 3 RED
- 4 GREEN
- 5 BLUE
- 6 ground RGBS
- 7 ground RGBS
- 8 Horizontal /composite sync
- 9 Vertical sync

Settings on module level

In the case of this second RGB input there are three different settings:

- 1. 75 Ω Termination resistor
- 2. Blue in Green switch
- 3. Force Negative Sync switch

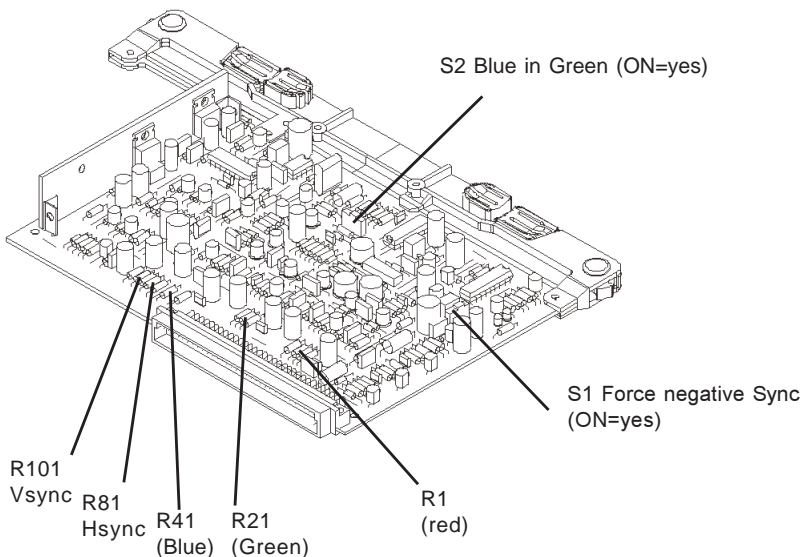

When changing a switch position or removing a resistor, turn off the projector and unplug the power cord from the wall outlet.

Location of the second RGB Module

The second RGB Module is inserted in the 4th slot of the main frame (Image 1).



image 1

How to remove the second RGB Module.

1. Press the module lock (Image 2)
2. Lift up the module handle (Image 3);
3. Repeat this action on both sides of the module
4. extract the module out of the main frame.

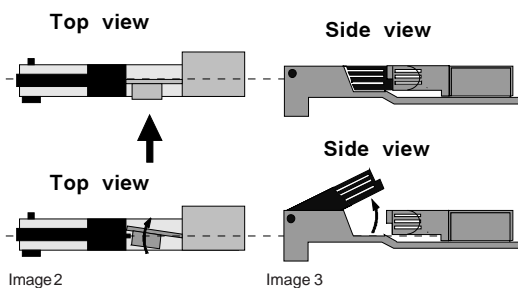

Image2

Image 3

75 Ω Termination resistors

In case of chaining (loop-through) the projectors, the 75 Ω line termination resistors must be removed from the second RGB Input Module when the projector is NOT the last unit in the chain.

In case of a stand-alone projector, do not remove the resistors.

- | | | |
|-------------------------------------|---|----------------------|
| 75 Ω resistors on the module | : | line terminated. |
| 75 Ω resistors removed | : | line not terminated. |

Removing the termination resistors

- 1 Turn off the projector and unplug the projector power cord.
- 2 Remove the top cover from the projector (see Access to).
- 3 Remove the RGB Input Module from the main frame.
- 4 Unsolder and remove the resistors.

Blue in Green Switch

Blue characters are difficult to read, therefore the blue text will be displayed as cyan so that the readability becomes better.

- | | | |
|----------------------------|---|-------------------------|
| Switch in the ON position | : | Blue in Green active. |
| Switch in the OFF position | : | Blue in Green disabled. |

Warning:

Leaving the switch in the ON position will result in abnormal color balance of the projected image.

Force Negative Sync Switch

- | | | |
|----------------------------|---|---|
| Switch in the ON position | : | the sync pulses must be negative. |
| Switch in the OFF position | : | the sync polarity will be automatically detected. |

How to select an RGB source:

Select the RGB input by pressing the numeric button 3 on the RCU or the local keypad.

Connecting a RGB Analog source to Port 4/5

RGB analog input terminals with separate H and V sync inputs, composite sync input or sync signals on green can be connected to the projector via Port 4/5. The projector automatically detects where the sync signal is located.

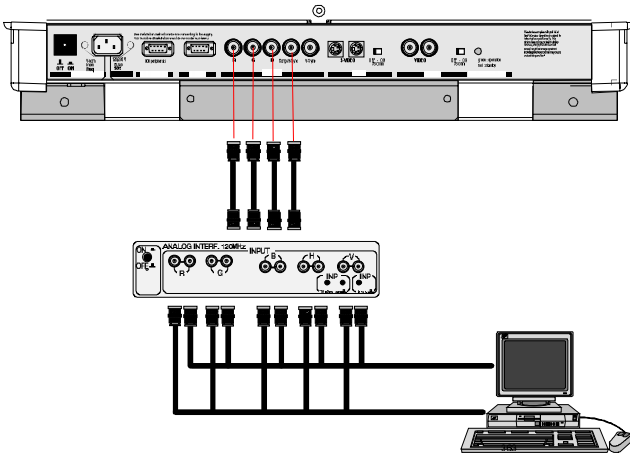

How to select the RGB Analog source :

Select the RGB analog source by pressing the *numeric button 4 or 5* on the RCU or the local keypad.

Interfaces to be used:

An interface is recommended when connecting a computer and local monitor to the projector. BARCO provides the following interfaces :

- 1. Universal Analog Interface.
- 2. RGB 120 MHz Analog Interface.

Connecting a Component Video source to Port 4/5

A component video (R-Y, Y, B-Y) with sync signals can be connected to the projector via Port 6. The projector automatically detects where the sync signal is located.

An HDTV interface is recommended when connecting a computer and local monitor to the projector. The HDTV Kit Order number : R9828040.

How to select the Component Video source :

Select the component video input by pressing the *numeric button 6* on the RCU or the local keypad.

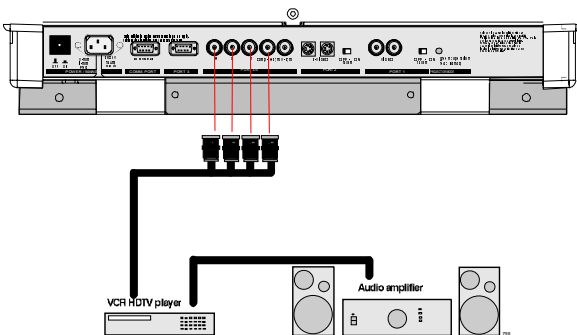

Connecting a RGB Analog source with Tri-level sync to Port 4/5

RGB analog input terminals with Tri-level sync input or with Tri-level sync on green can be connected to the projector via Port 4/5. The projector detects automatically where the sync signal is located.

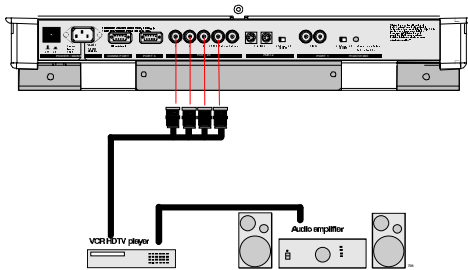

How to select the RGB input Analog source :

Select the RGB Analog source input by pressing the *numeric button 7* on the RCU or the local keypad.

Connecting a Component Video source with Tri-level sync to Port 4/5

Component video inputs with Tri-level sync signal can be connected to the projector via Port 8. The projector detects automatically where the sync signal is located.

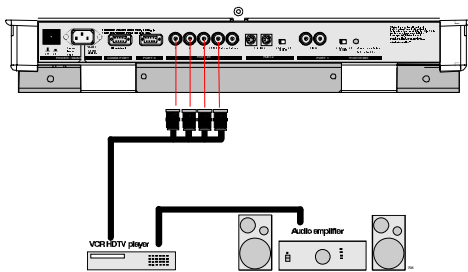

How to select the component video source :

Select the the component video source by pressing the numeric button 8 on the RCU or the local keypad.

Communication connections

Communication facilities :

1. RS232 in / RS232 out.
2. Comm port for communication with peripheral (switchable between PPM and RC5)
3. RC for remote cable connection with the RCU.
4. MOUSE to control a PC with the projector remote control.
5. TRIG : output voltage to control another device.

Peripheral types

The following source types can be connected to the inputs :

- 1 RCDVS 05 source selector
- 2 VS 05 source selector
- 3 IR remote receiver 800

Connecting a RCVDS 05 source selector

- 1 Up to 20 inputs with a RCVDS05 and up to 90 inputs can be accommodated when multiple RCVDS source selectors are linked via a Expansion Module.
- 2 Serial communication with the projector.
- 3 Remote control buttons on the RCVDS05 to control the projector (source selection and analog settings).
- 4 The selected source number will be displayed on a 2-digit display and the selected input modules will be indicated with a LED on the rear.

The order numbers for the RCVDS05 source selector :

RCVDS05 230 V	R9827880
RCVDS05 120 V	R9827889

For more information about the use of the RCVDS05, consult the RCVDS05 Owner's Manual - order number : R5975765.

Connecting a VS05 source selector

The VS05 can switch up to 5 Composite Video sources, 3 S-Video Sources and 1 RGB analog or component Video source to the projector. In addition, the audio signal associated with the source, can be switched to an audio amplifier.
VS05 order number : R9827890.

For more information about the use of the VS05, consult the VS05 Owner's Manual - order number : R5975245.

Connecting an IR Remote Receiver 800

This infrared Remote Receiver makes it possible to control the projector from another room. There is a communication cable between the IR Remote Receiver and the projector. The control information from the RCU can now be sent to the IR Remote Receiver 800. The IR Remote Receiver 800 displays the selected source on a 7-segment display.
IR Remote Receiver 800 order number : R9827515.

7

INSTALLATION ADJUSTMENT MODE

Installation adjustment mode

Access to the Service Menus

- 1 Press the **ADJUST** key.
The projector displays the 'Main Menu' (menu 1)

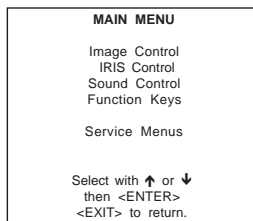

menu 1

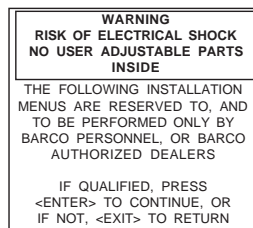

menu 2

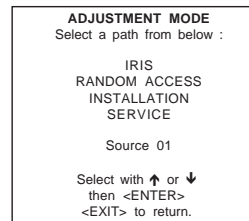

menu 3

- 2 Push the cursor key **↑** or **↓** to highlight the path 'Service Menus' in menu 1.
- 3 press **ENTER**.
- 4 A warning will be displayed on the screen (menu 2). If you are qualified and authorized service person, press **ENTER** to start up the installation mode. Otherwise, press **EXIT** to return
- 4 Push the cursor key **↑** or **↓** to highlight the path 'Installation' in menu 2.
- 5 A warning will be displayed on the screen. If you are qualified and authorized service person, press **ENTER** to start up the installation mode. Otherwise, press **EXIT** to return
When entering the installation mode the projector will automatically switch to the internal pattern on 15kHz/50 Hz.

When the password mode is active, you will be requested to enter the 4 digit password.

Password Protection

Some items in the Adjustment mode are password protected. While selecting such an item, the projector asks to enter your password. (Password protection is only available when the password strap on the controller module is ON. (Contact a BARCO authorized technician when no password is requested during the adjustment procedure and password protection is desired.)

Entering the password

Your password contains 4 digits.
Enter the digits with the numeric keys on the RCU.
Example : 2 3 1 9
For each digit entered, a 'X' appears on the screen under the displayed text 'enter password'.



Remark

When the password is correctly entered, all other password protected items are accessible without re-entering the password.
When re-entering the adjustment mode, it will be necessary to enter your password again when selecting a password protected item.

Overview flowchart of the installation Adjustment mode

Following flowchart gives the different submenus within the 'Installation' menu.

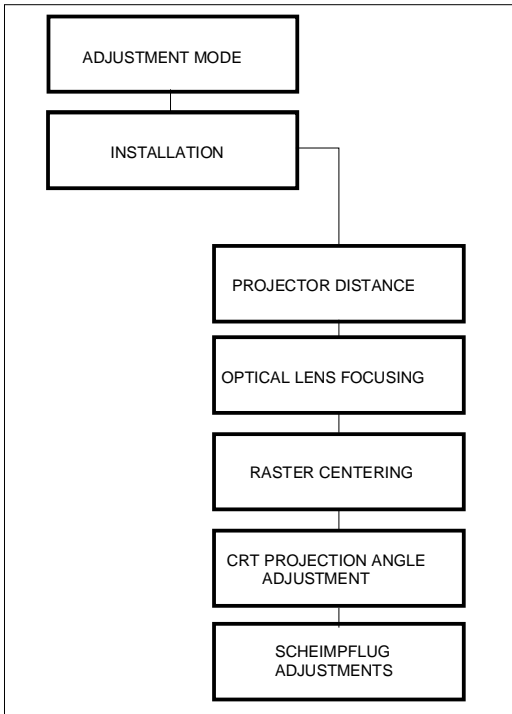

Flowchart 1

Access to adjustments

The top cover of the projector should be removed in order to gain access to the adjustments. Please refer to 'Removing the top cover' for how to remove the top cover.

Projector Distance

On the screen, a drawing (Projection distance 1 Menu) will be displayed together with parameters indicating a correct position.

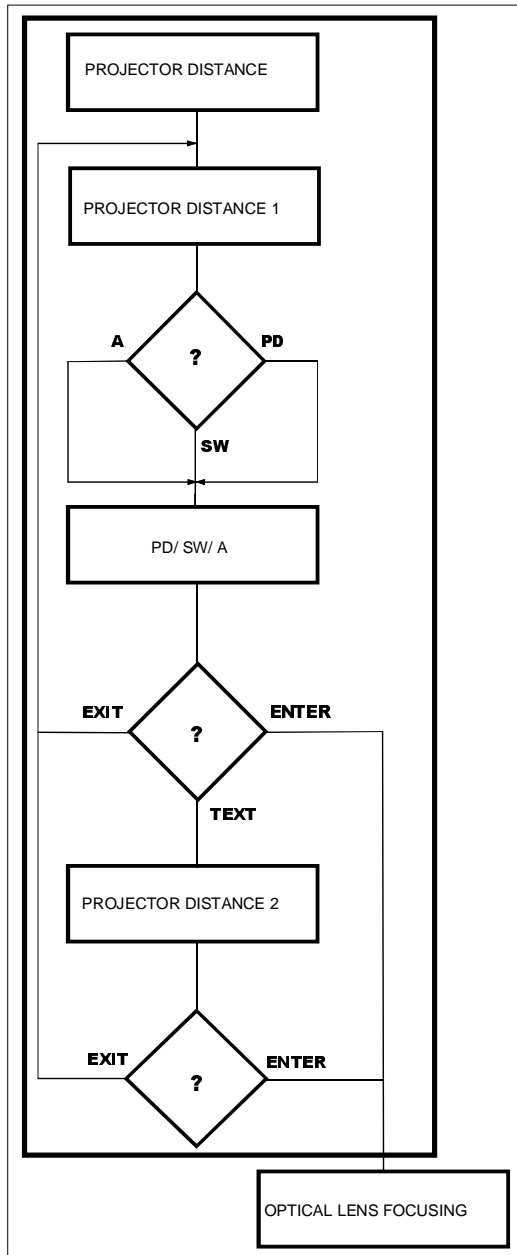

Flowchart 2

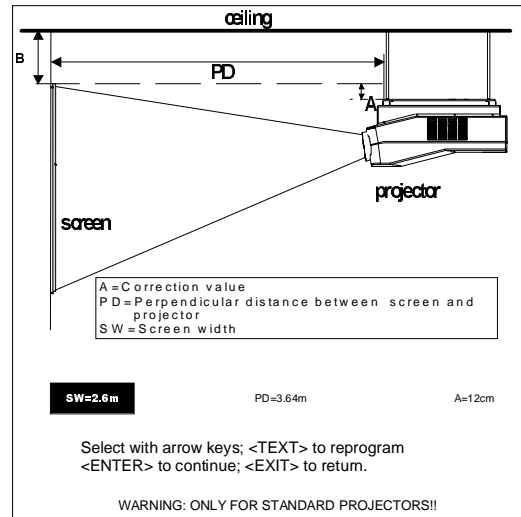

Projection distance 1 Menu

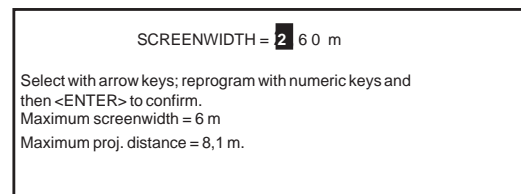

Projection distance 2 Menu

To change the screen width (see flowchart above) :

- 1 Push the cursor key **←** or **→** to highlight the item *SW* in the "Projector distance 1" menu and then press **TEXT**. If **ENTER** is pressed, the "Optical Lens Focusing" will be displayed.
If **EXIT** is pressed, the projector will return to the previous menu.
- 2 After **TEXT** is pressed, the next menu "Projector distance 2" will be displayed on the screen. It allows the user to change the Screen width.
- 3 Push the cursor key **←** or **→** to highlight the digit needed to be changed, and enter the desired digit with the numeric keys on the RCU or the local keypad.
- 4 Press **ENTER** to confirm the changes. The projector will redisplay the "Projector distance 1" menu with updated values for the three parameters.
- 5 Press **ENTER** to continue with the "Optical Lens Focusing".
If **EXIT** is pressed, the projector will return to the previous menu.

The same applies to the PD (projector distance). You can use the above-mentioned procedure to obtain a correct updated value of SW (screenwidth) after entering a new value of PD (projector distance).

Optical Lens Focusing

The optical focusing procedure is performed separately for each lens. The appropriate CRT will be switched on as the user proceeds through the optical focusing adjustment sequence. Following screen will be projected for each lens :

OPTICAL LENS FOCUSING

1.LOOSEN THE NUT ON THE REAR OF THE GREEN LENS, ROTATE THE LENS BARREL TO FOCUS THE CENTER OF THE IMAGE THEN TIGHTEN THE NUT

2.LOOSEN THE NUT ON THE FRONT OF THE GREEN LENS, ROTATE THE FRONT SECTION OF THE LENS TO FOCUS THE CORNERS OF THE IMAGE THEN TIGHTEN THE NUT

<ENTER> TO CONTINUE
<EXIT> TO RETURN

Each lens has two focus adjustment points, one at the rear of the lens and one at the front.

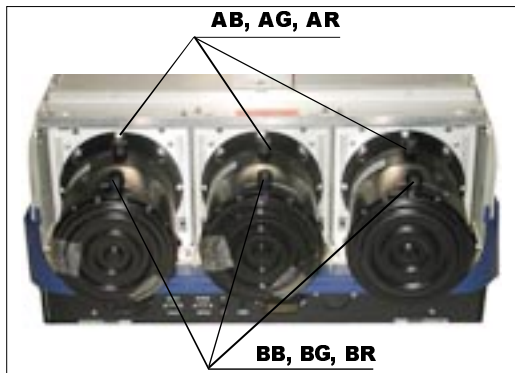

Image 1

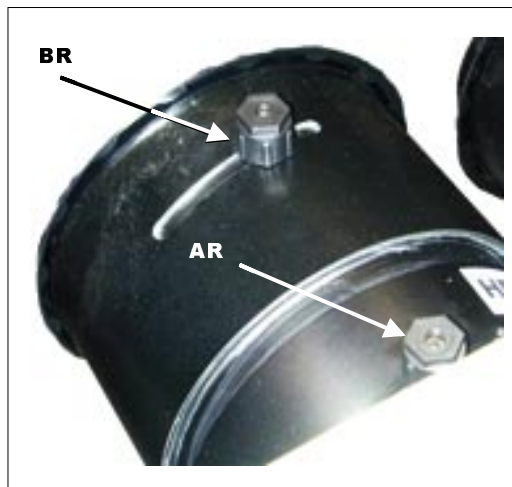

Image 2

To focus the center of the projected image:

- 1 loosen the wing nut at the rear end of the lens (AB,AG,AR on Image 1)
- 2 rotate the lens barrel until the center of the image is clearly focused.

To focus the corners of the projected image:

- 1 loosen the wing nut at the front end of the lens (BB,BG,BR on Image 1)
- 2 rotate the lens barrel until the corners of the image are clearly focused.

Repetition of these adjustments may be necessary to optimize optical focusing.

Press **ENTER** to continue. After finishing focusing of the three lenses, press **ENTER** to enter the Raster centering.
Press **EXIT** to return to operational mode.
Press **ADJUST** to return to operational mode.

Raster centering

The raster must be centered on the CRT faceplate of each tube, therefore, it is necessary to look into the lenses.

Contrast and brightness settings during Raster centering

To avoid eye discomfort while performing these adjustments, reduce the contrast and gradually increase the brightness level until the raster becomes visible behind the image.

CRT damage

In order to ensure maximum CRT longevity and to avoid CRT damage, do not shift the raster outside the phosphor area or the CRT.

How to center the raster:

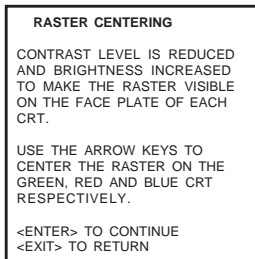

- 1 Press the **ENTER** key to display the raster on the green CRT.
- 2 Look into the green lens and shift the raster with the cursor key until it is centered in the middle of the CRT faceplate.
- 3 Press the **ENTER** key to activate the raster on the Red CRT faceplate.
- 4 Shift the Red raster with the cursor key until the raster is centered on the CRT faceplate.
- 5 Press the **ENTER** key to activate the raster on the Blue CRT faceplate.
- 6 Shift the Blue raster with the cursor key until the raster is centered on the CRT faceplate.

Press the **ENTER** key to continue with the CRT projection angle adjustment.

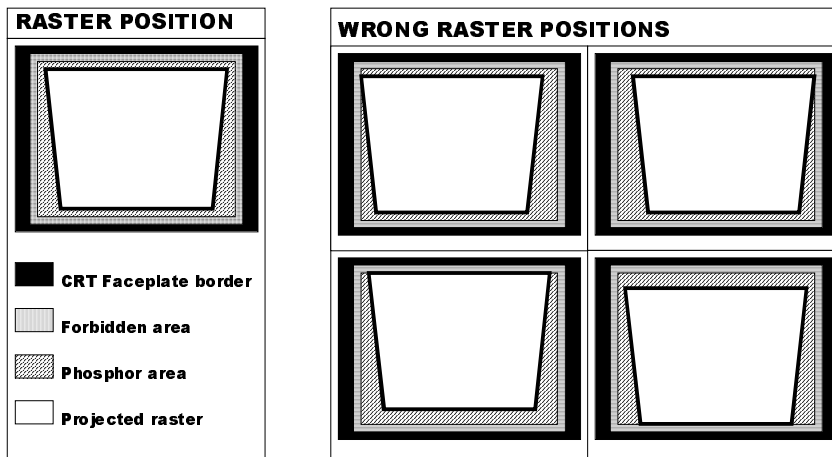

CRT Phosphor width

Following phosphor is used for the green color:

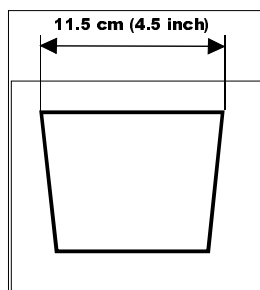

CRT Projection Angle Adjustment

The projection angle of the red and blue CRT's is dependent on the desired size of the projected image. If the centers of green, blue and red do not coincide, the CRT projection angle must be adjusted.

Note

Never try to correct this misalignment with the shift correction or the static convergence controls. These controls may only be applied to correct small errors which cannot be corrected by the CRT angle adjustment. Note: The Horizontal Shift and Vertical Shift for Red and Blue should be set near 50%.

Be sure that the rasters are centered on the CRT faceplate.

How to adjust the Projection angle:

- 1 Press **ENTER** to start the CRT angle adjustment procedure (Menu 1).
- 2 Press **ENTER** to continue with the crosshair alignment (Menu 2).
- 3 Loosen bolts A, B, C and D to pivot the red CRT until the center of the Red image and the center of the Green image coincide (Menu 3).
- 4 When the angle of the red CRT is corrected, tighten the four bolts.
- 5 Press **ENTER** to continue with the alignment of the blue CRT.
Press **EXIT** to return to the CRT projection angle adjustment menu.
- 6 Loosen bolts E, F, G and H (Image 1) to pivot the blue CRT until the center of the Blue image and the center of the Green image coincide (Menu 4).
When the angle of the blue CRT is corrected, tighten the four bolts.

Press **ENTER** to continue with the diagonal focusing menu.

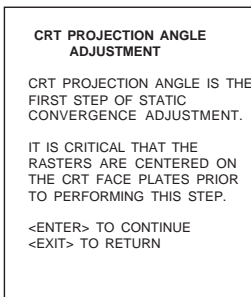

Menu 1

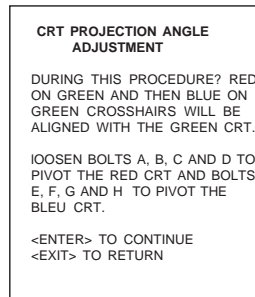

Menu 2

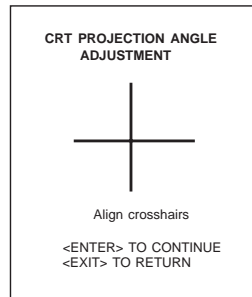

Menu 3

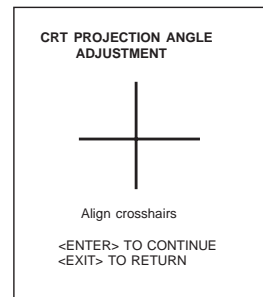

Menu 4

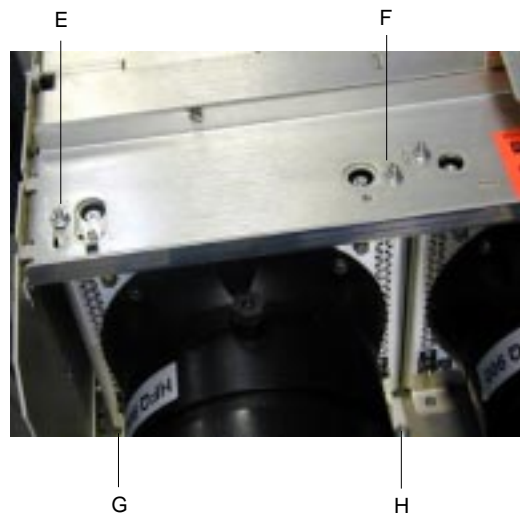
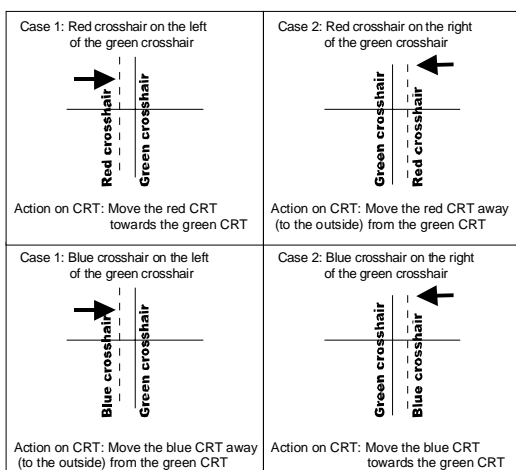

Image 1

A new projection angle adjustment is required whenever a new screenwidth SW is adopted.

Scheimpflug Adjustment (Diagonal image focusing)

Why?

With the diagonal image focusing corrections, it is possible to obtain uniform focus for the total projected image. These corrections must be repeated for each color. The Diagonal image focusing is repeated 3 times, first for green, then for red and then for blue.

Attention

First, be sure that the CRT projection angle is correctly adjusted, otherwise it is not possible to obtain proper overall focus of the image.

Scheimpflug Adjustment Procedure

- 1 Press **ENTER** to start the green adjustment (Menu 1).
Press **EXIT** to return to CRT Projection Angle Adjustment.
Press **ADJUST** to return to Operational mode.

Example: Scheimpflug Adjustment for the Red color

- 2 Equalize diagonally the focus from left (bottom) to right (top) by turning screw 03 of the projected color (Image 1).
- 3 Equalize now diagonally the focus from left (top) to right (bottom) by turning screw 02 (Image 2).

DIAGONAL IMAGE FOCUSING	
1.	TURN THE SCREW MARKED 01 TO FOCUS THE IMAGE DIAGONALLY FROM LEFT (BOTTOM) TO RIGHT (TOP).
2.	TURN THE SCREW MARKED 02 TO FOCUS THE IMAGE DIAGONALLY FROM LEFT (TOP) TO RIGHT (BOTTOM).
<ENTER> TO CONTINUE	
<EXIT> TO RETURN	

Menu 1

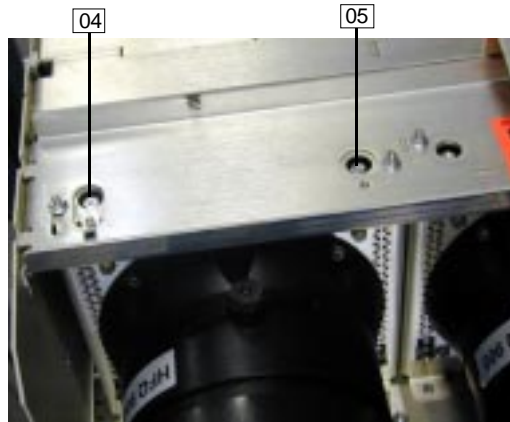
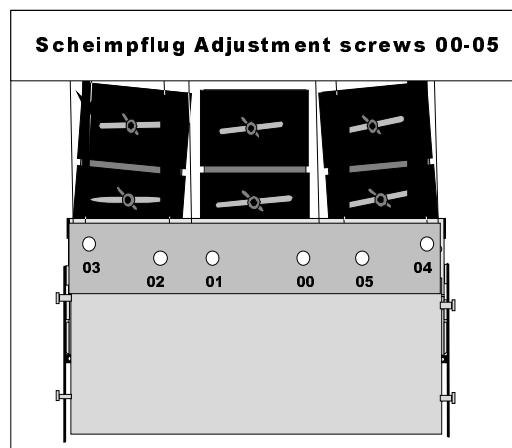

Image 1

Green	00	01
Red	02	03
Bleu	04	05



To optimize the image focusing, repeat the optical lens focusing. After finishing the Installation Adjustment Procedure, the main menu returns on the screen.

8

MESSAGES, WARNINGS AND FAILURES

<p>INPUT 01 RGB2 Fh= 15.6 kHz Fv= 050 Hz</p>	<p>When selecting a new source, information about this source will be displayed on the screen. Source number, horizontal and vertical frequencies of the displayed source.</p>	<p>WARNING: input not available</p>	<p>When using the projector with the RCVDS, this warning will be displayed when selecting an input slot of an RCVDS where the input board is missing.</p>
<p>SOURCE 01 RGB2</p>	<p>Announcement of the selected source.</p>	<p>WARNING: source not available</p>	<p>The input is a valid input but the source is not connected to the input terminals or the input source is switched off.</p>
<p>enter password x x x x</p>	<p>Message to enter your password. Password contains 4 digits.</p>	<p>WARNING: invalid key entry</p>	<p>When a wrong key is pressed on the RCU.</p>
<p>TEXT on SOURCE 01 RGB2 xxxkHz xxHz</p>	<p>These messages will be displayed on the screen when pushing the TEXT key.</p>	<p>WARNING: end of adjustment range</p>	<p>End of adjustment range.</p>
<p>TEXT off</p>	<p>Text ON : the '<i>bar scale indication</i>' will be enabled during the change of an analog control in the '<i>operational mode</i>' + all warnings and failures will be displayed.</p>	<p>WARNING: input no longer available</p>	<p>The input source is no longer available.</p>
<p>PROJECTOR ADDRESS: 003</p>	<p>Text OFF : the '<i>bar scale indication</i>' will be disabled during the change of an analog control in the '<i>operational mode</i>' + all warnings and failures will not be displayed.</p>	<p>WARNING: RCVDS not available</p>	<p>The input source selector is not available.</p>
<p>WRONG PASSWORD !!!</p>	<p>Indication of the projector address when activating the '<i>ADDRESS</i>' button on the RCU with a pencil or other small object.</p>	<p>WARNING: invalid frequency input</p>	<p>The entered frequency or applied frequency of the source is out of the projector's range.</p>
	<p>Message when the entered password is wrong.</p>	<p>WARNING: permanent BOOST mode in use !!!</p>	<p>The CRT drive mode is switched to permanent boost.</p>
		<p>WARNING: Option not installed !</p>	<p>Option not installed. e.g. Video selected but no decoder installed.</p>
		<p>WARNING: Invalid Code Entry</p>	<p>The entered password is incorrect</p>

FAILURE
I2C error
addr. : 7FH3

Hardware failure. Call a qualified service technician for repair.

FAILURE
short
circuit on
I2C bus

Hardware failure. Call a qualified service technician for repair.

FAILURE
RCVDS com-
munication
error

Serial communication error between the RCVDS and the projector.

FAILURE
invalid input

input not valid

FAILURE
PC communica-
tion error

error in the communication between the projector and the PC.

FAN FAILED
Projector will
switch off

projector switched off due to a fan fail.

FAILURE
IRIS II
configuration
failed

Error occurred while configuring the IRIS II module.

A

BARCO CEILING MOUNT SUPPORT

Introduction

This appendix gives only an overview of the contents of the installation guidelines and some overview drawings. The installation guidelines for the BARCO ceiling mounting support can be ordered from BARCO. The order number: R5975693.

Contents of the installation guidelines

- 1 Mounting instructions for the upper support to the ceiling
 - a Position of the upper support on the ceiling
 - b Mounting of the 4 screwed rods on the upper support
- 2 Projector placement on lower support
 - a Projector placement on support
 - b Location of controls for projector-position correction
- 3 Mounting instructions of the cord to lift up the projector
 - a Mounting the cord support on the upper support
 - b Cord insertion between the upper and lower support
 - c Cord fixation
- 4 Lifting up and fixing the lower support (with projector) on the screwed rods
- 5 Alignment of the projector-support assembly
 - a Projector water-level adjustment
 - b Adjustment "projector axis perpendicular" to the screen surface
 - c Projector movement forward or backward

Exploded view of BARCO ceiling mount support (Image 1)
Overview drawing of the total system (Image 2)

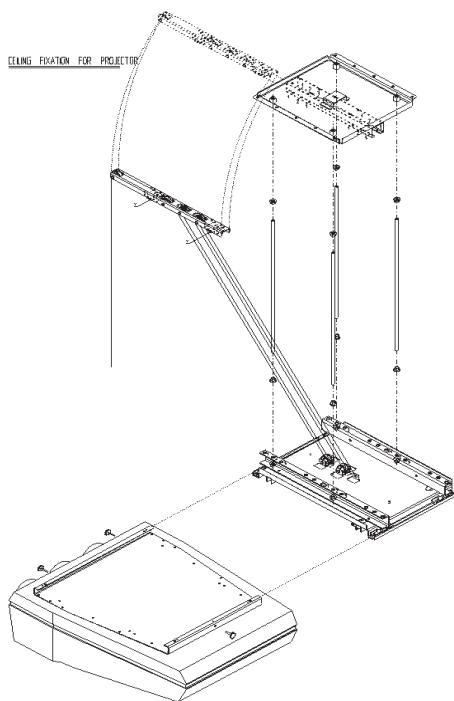

Image 1

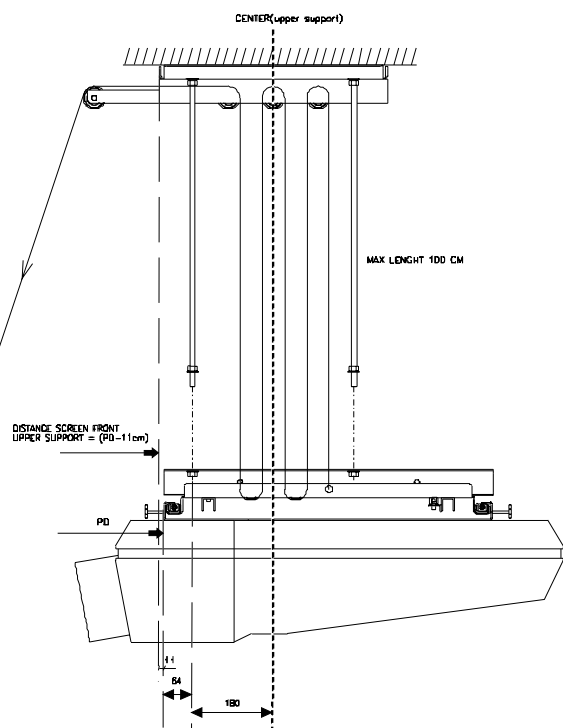

Image 2



GAMMA CORRECTIONS

Gamma corrections

Gamma warning

When entering the gamma corrections, a warning will be displayed (Menu 1) :

"RISK OF INCORRECT ADJUSTMENT OF THE PROJECTOR.
THE GAMMA CORRECTIONS ARE FACTORY ADJUSTED USING AN ACTAS COLOR ANALYZER ! THEREFORE, ONLY QUALIFIED INSTALLATION OR SERVICE PERSONNEL SHOULD PERFORM THESE ADJUSTMENTS ! "

If you are qualified, press **ENTER** to continue.

Procedure for Gamma corrections

There are three settings in the gamma correction menu (Menu 2):

- 1 Blue gamma correction
- 2 R&B midlights
- 3 Factory preset

To carry out the Blue Gamma Correction : ← or →, ↑ or ↓

- 1 Push the cursor key **↑** or **↓** to highlight BLUE GAMMA CORRECTION in the menu and then press the **ENTER** key (Menu 2). If the **EXIT** key is pressed, the projector will return to the *Service* menu.
- 2 After the **ENTER** key is pressed, a text box with the message, "Adjust with arrow key", will be displayed on the screen (Menu 3).
- 3 Push the cursor key **↑** or **↓** to adjust the slope, a text box with a bar scale (Min to Max) will be displayed to visualize the magnitude of the correction (Menu 4).
- 4 Push the cursor key **←** or **→** to adjust the breakpoint, a text box with a numeric bar scale (0-99) will be displayed to visualize the magnitude of the correction (menu 5).
- 5 Press the **ENTER** key to return to the "Gamma Corrections" menu.

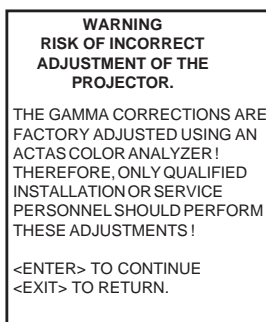

Menu 1

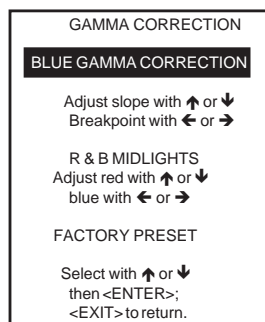

Menu 2

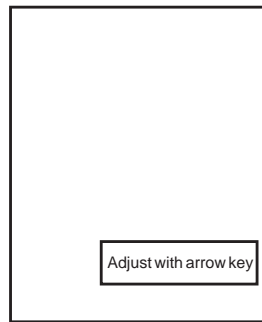

Menu 3

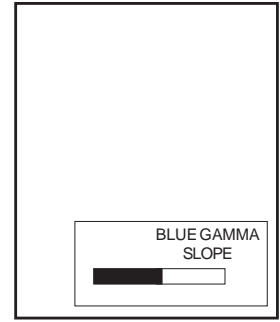

Menu 4

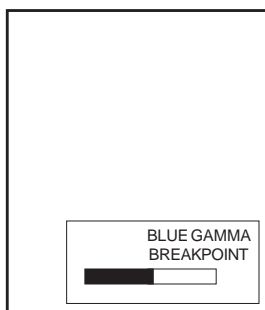

Menu 5

To carry out the Red and Blue Midlights Correction:

- 1 Push the cursor key ↑ or ↓ to highlight the item R&B MIDLIGHTS in the menu and then press the **ENTER** key (Menu 1). If the **EXIT** key is pressed, the projector will return to the *Service* menu.
- 2 Push the cursor key ↑ or ↓ to adjust the Red Midlights, a text box with a bar scale (0-16) will be displayed to visualize the magnitude of the correction (Menu 3).
- 3 Push the cursor key ← or → to adjust the Blue Midlights, a text box with a bar scale (0-16) will be displayed to visualize the magnitude of the correction (Menu 4).
- 4 Press the **ENTER** key to return to the "Gamma Corrections" menu.

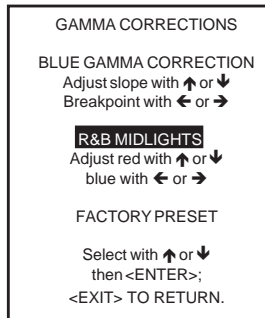

Menu 1

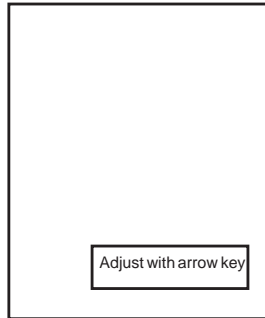

Menu 2

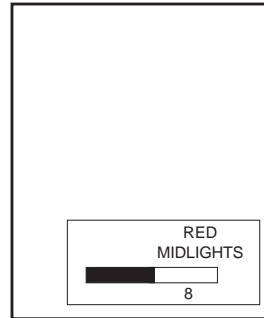

Menu 3

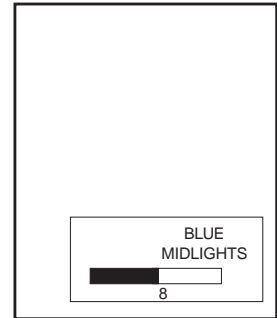

Menu 4

To set the parameters back to the factory preset values :

- 1 Push the cursor key ↑ or ↓ to highlight the item FACTORY PRESET in the menu and then press the **ENTER** key (Menu 5). Press the **EXIT** key to return to the 'Service' menu.

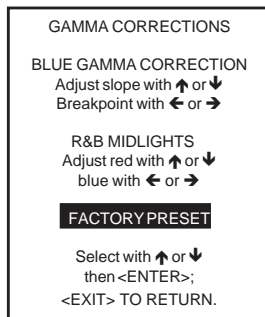

Menu 5

MATERIAL SAFETY DATA SHEET					Form Approved Bureau Budget No. 45-R0338		
SECTION I	MANUFACTURER'S NAME AND FSCM (<i>Federal Supply Code for Manufacturer's</i>) <i>BARCON.V.</i>				EMERGENCY PHONE NO. <i>32-56-368211</i>		
	ADDRESS (<i>Number, Street, City, State, and ZIP Code</i>) <i>Noordlaan 5 B-8520 KUURNE</i>						
	CHEMICAL NAME AND SYNONYMS <i>Ethylenglycol & Glycerol</i>			TRADE NAME AND SYNONYMS <i>Cooling liquid 512334</i>			
	CHEMICAL FAMILY <i>Polyalcohols</i>		FORMULA <i>C₂H₆O₂+C₃H₈O₃</i>				
	FEDERAL STOCK NUMBER (<i>FSN</i>)		GROSS WEIGHT (<i>LBS</i>)		OUTSIDE PACKAGE DIMENSIONS (<i>Inches</i>)		
	MIL-STD-1341/NATIONAL FIRE PROTECTION ASSOCIATION STD 704M SIGNAL FLAMMABILITY..... HEALTH..... REACTIVITY..... SPECIFIC HAZARD.....						
SECTION II - HAZARDOUS INGREDIENTS	PAINTS, PRESERVATIVES, AND SOLVENTS	%	TRESHOLD LIMIT VALUE (<i>Units</i>)	ALLOYS AND METALLIC COATINGS	%	TRESHOLD LIMIT VALUE (<i>Units</i>)	
	PIGMENTS	/		BASE METAL	/		
	CATALYST	/		ALLOYS	/		
	VEHICLE	/		METALLIC COATINGS	/		
	SOLVENTS	/		FILLER METAL PLUS COATING OR CORE FLUX	/		
	ADDITIVES	/		OTHERS	/		
	OTHERS	/					
	HAZARDOUS MIXTURES OF OTHER LIQUIDS, SOLIDS, OR GASES					%	TRESHOLD LIMIT VALUE (<i>Units</i>)
SECTION III PHYSICAL DATA	BOILING POINTS (<i>°C.</i>)	<i>201°C</i>		SPECIFIC GRAVITY (<i>H₂O=1</i>)	<i>1.15</i>		
	VAPOR PRESSURE (<i>mm Hg.</i>)	<i>3 mm Hg</i>		PERCENT VOLATILE BY VOLUME (%)	/		
	VAPOR DENSITY (<i>AIR=1</i>)	<i>2.2</i>		EVAPORATION RATE (<i>.....=1</i>)	/		
	SOLUBILITY IN WATER	∞					
	APPEARANCE AND ODOR						
SECTION IV - FIRE AND EXPLOSION HAZARD DATA	FLASH POINT (<i>Method used</i>)			FLAMMABLE LIMITS	LOWER EXPLOSIVE LIMIT	UPPER EXPLOSIVE LIMIT	
	EXTINGUISHING MEDIA						
	SPECIAL FIRE FIGHTING PROCEDURES						
	UNUSUAL FIRE AND EXPLOSION HAZARDS						

SECTION V HEALTH HAZARD DATA	TRESHOLD LIMIT VALUE <i>100ppm</i>			
	EFFECTS OF OVEREXPOSURE			
	EMERGENCY AND FIRST AID PROCEDURES			
SECTION VI REACTIVITY DATA	STABILITY	UNSTABLE		CONDITIONS TO AVOID
		STABLE	X	
	INCOMPATABILITY (<i>Materials to avoid</i>)			
	HAZARDOUS DECOMPOSITION PRODUCTS			
	HAZARDOUS POLYMERIZATION	MAY OCCUR	X	CONDITIONS TO AVOID
WILL NOT OCCUR				
SECTION VII SPILL OR LEAK PROCEDURES	STEPS TO BE TAKEN IN CASE MATERIAL IS RELEASED OR SPILLED			
	<i>Rinse with water</i>			
	WASTE DISPOSAL METHOD			
SECTION VIII - SPECIAL PROTECTION INFORMATION	RESPIRATORY PROTECTION (<i>Specific type</i>)			
	VENTILATION	LOCAL EXHAUST		SPECIAL
		MECHANICAL (<i>General</i>)		OTHER
	PROTECTIVE GLOVES		EYE PROTECTION	
	OTHER PROTECTIVE EQUIPMENT			
SECTION IX SPECIAL PRECAUTIONS	PRECAUTIONS TO BE TAKEN IN HANDLING AND STORING			
	<i>Harmful if swallowed</i>			
	<i>Keep out of the reach of children</i>			
OTHER PRECAUTIONS		<i>To avoid from oxidants</i>		

THE INFORMATION CONTAINED HEREIN IS BASED ON DATA CONSIDERED ACCURATE. HOWEVER, NO WARRANTY IS EXPRESSED OR IMPLIED REGARDING THE ACCURACY OF THESE DATA OR THE RESULTS TO BE OBTAINED FROM THE USE THEREOF. VENDOR ASSUMES NO RESPONSABILITY FOR INJURY TO VENDEE OR THIRD PERSONS PROXIMATELY CAUSED BY THE MATERIAL IF REASONABLE SAFETY PROCEDURES ARE NOT ADHERED TO AS STIPULATED IN THE DATA SHEET. ADDITIONALLY, VENDOR ASSUMES NO RESPONSABILITY FOR INJURY TO VENDEE OR THIRD PERSONS PROXIMATELY CAUSED BY ABNORMAL USE OF THE MATERIAL EVEN REASONABLE SAFETY PROCEDURES ARE FOLLOWED. FUTHERMORE, VENDEE ASSUMES THE RISK IN HIS USE OF THE MATERIAL.