

ESPRIT
PROJECTION SYSTEMS

AmPro Corporation
1301 Armstrong Drive
Titusville, Florida 32780-7999 USA
(407) 269-6680 Fax (407) 267-6211

SERVICE

MANUAL

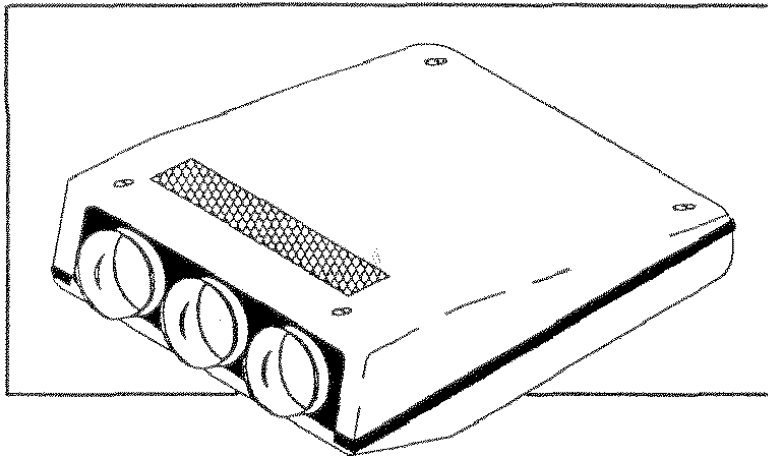

ESPRIT SERIES 2000D / 2000G

MODELS 69202, 69203

APRIL 1991 REVISION A
AMPRO P/N 71068

Before operating this Video/Computer Graphics Display System, please read this manual carefully and completely. This manual will provide you with a full understanding of the many functions and special features, and the necessary instructions for adjustments and operation of this equipment.

Please follow all notes and warnings.



Made
In the
U.S.A.

ESPRIT 2000D/G TECHNICAL REFERENCE MANUAL
CONTENTS

SECTION 1

GENERAL INFORMATION

WARNING AND PRECAUTIONS	1-1
SPECIFICATIONS	1-4
SYSTEM DIMENSIONS	1-5
REAR PANEL LAYOUT	1-6
FAN FILTERS REMOVAL CLEANING	1-7
MODULE DESCRIPTIONS	1-8
SYSTEM TROUBLE SHOOTING	1-11

SECTION 2

SCHEMATICS AND BLOCK DIAGRAMS

MOTHER BOARD INTERCONNECT	2-1
I ² C CPU MODULE	2-4
I ² C ADDRESS GUIDE	2-9
QUAD DECODER W/S-VHS	2-10
VIDEO SELECT BOARD	2-13
ANALOG RGB1 MODULE	2-14
SYNC PROCESSOR	2-17
TTL MODULE	2-18
ANALOG RGB2 MODULE	2-20
TEST/TEXT INTERFACE MODULE	2-23
CRT AMPLIFIER CARD	2-25
VERTICAL DEFLECTION MODULE	2-27
2000G HORIZONTAL DEFLECTION MODULE	2-30
2000D HORIZONTAL DEFLECTION MODULE	2-33
H.O.T MODULE	2-35
YOKE BOARD	2-37
SMPS (SWITCH MODE POWER SUPPLY)	2-38
SMPS REGULATOR BOARD	2-40
HYBRID REGISTRATION BOARD	2-41
REGISTRATION MUX BOARD	2-53
REGISTRATION VERTICAL FILTER BD.	2-56
REGISTRATION AMPLIFIER BOARD	2-57
FOCUS MODULATOR	2-58

SECTION 3

MODULE AND CRT REPLACEMENT PROCEDURES

CPU	3-1
QUAD VIDEO DECODER	3-3
QUAD VIDEO DECODER FIELD INSTALLATION SUPPLEMENT	3-5
ANALOG RGB1	3-7
TTL/VGA	3-11
TTL/VGA FILED INSTALLATION SUPPLEMENT	3-13
ANALOG RGB2	3-15
ANALOG RGB2 FILED INSTALLATION SUPPLEMENT	3-17
TEST/TEXT INTERFACE	3-19
CRT AMPLIFIER CARD	3-21
VERTICAL DEFLECTION	3-23
HORIZONTAL DEFLECTION	3-25
H.O.T.	3-27
SWITCH MODE POWER SUPPLY	3-29
REGISTRATION BOARD	3-31
REGISTRATION AMPLIFIER	3-33
HIGH VOLTAGE POWER SUPPLY	3-35
7 INCH CRT	3-37
7 INCH CRT ASSEMBLY EXPLODED PARTS VIEW	3-40
LENS/BRACKET EXPLODED PARTS VIEW	3-41
7 INCH PIVOTING HEAD ASSEMBLY EXPLODED PARTS VIEW	3-42

APPENDIX A





SETUP PROCEDURE

ASTIGMATOR	A2
BEAM CENTERING	A2
ELECTROSTATIC FOCUS	A2
RED AND BLUE HEIGHT	A2
G2 CUTOFF	A2

GLOSSARY

WARRANTY CLAIM FORM

WARNINGS AND PRECAUTIONS

	<p>CAUTION RISK OF ELECTRICAL SHOCK DO NOT OPEN</p>			
<p>CAUTION: TO REDUCE THE RISK OF ELECTRIC SHOCK DO NOT REMOVE COVER (OR BACK) NO USER SERVICEABLE PARTS INSIDE REFER TO SERVICING TO QUALIFIED SERVICE PERSONNEL</p>			<p>This symbol is intended to alert the user that parts inside this product are a risk of electric shock to persons.</p>	<p>This symbol is intended to alert the user that important operating and servicing (maintenance) instructions are in the literature accompanying this product.</p>

X-RADIATION 

During the operation of any solid state Data/Computer display system, the picture tube is a primary source of x-radiation. The projection tubes in ESPRIT systems incorporate leaded glass to safeguard against the leakage of x-rays. ESPRIT projectors comply with all U.S. Department of Health and Human Services rules governing the emission of x-radiation. **FOR CONTINUED X-RADIATION PROTECTION THE USER SHOULD NEVER ATTEMPT TO REPLACE THE PROJECTION TUBES OR OTHER ELECTRONIC COMPONENTS.** Instead, all service to the system should be performed by a qualified service technician.

X-RAY SHIELD
DO NOT REMOVE

"WARNING"
COMPONENTS FOR X-RAY SAFETY ARE CONTAINED IN THIS POWER SUPPLY RETURN COMPLETE HIGH VOLTAGE MODULES TO FACTORY FOR REPLACEMENT AND CONTINUED SAFETY

NOTE

THE DEFLECTION YOKES MUST BE FIRMLY AGAINST THE BELL OF THE CRT TO PREVENT X-RADIATION.

"WARNING"
BACKWARD MOVEMENT OF THE YOKE RESULTS IN PICTURE DEGRADATION AND LOSS OF RADIATION PROTECTION

HIGH VOLTAGE



The projection display system contains high voltage derived from supplies capable of delivering **LETHAL** quantities of energy. To avoid serious personal injury, only a qualified technician should service and adjust the internal modules within the unit. There are no user serviceable parts in the ESPRIT system. All internal servicing must be performed by a qualified technician.

HIGH VOLTAGE

THIS UNIT OPERATES AT 34KV MAX

EXPOSURE TO RAIN OR MOISTURE



To reduce **FIRE** or **SHOCK HAZARD**, never expose the system to rain or moisture. If this happens inadvertently, do not use the system until it has been inspected and/or serviced by a qualified technician.

PROJECTION TUBES



The projection tubes inside the system enclose a high vacuum. Care must be taken to ensure that the system is not dropped or otherwise subject to violent blows.

WARNING

ATTEMPTS TO ALTER THE SEALED FACTORY-SET INTERNAL CONTROLS OR TO CHANGE OTHER SETTINGS NOT SPECIFICALLY DISCUSSED IN THIS MANUAL CAN LEAD TO PERMANENT DAMAGE TO THE PROJECTION SYSTEM AND VOID THE WARRANTY.

A.C. LINE / ELECTRICAL GROUNDING OF EQUIPMENT



The ESPRIT projection system is configured for 115V or 230V operation and supplied with one of four standard power cords, as specified at the time the system is ordered. To change configurations, refer to paragraph 5.7. For your safety and proper operation, the system **MUST** be connected to a properly wired and grounded outlet. An improperly grounded system can place **HAZARDOUS VOLTAGES** on accessible metal parts of the system chassis and voids the Warranty due to potential damage to the system.

FOR INTERNAL ADJUSTMENTS OR SERVICE REFER TO QUALIFIED PERSONNEL. THE POWER CORD PROTECTIVE GROUNDING CONDUCTOR MUST BE CONNECTED TO EARTH GROUND. FOR CONTINUED SAFETY AND PROTECTION REPLACE FUSE WITH SPECIFIED TYPE: 110 - 220V 5 AMP 220 - 240V 3 AMP
AGC SLO-BLO AGC SLO-BLO

CRT PHOSPHOR LIFE CRITERIA



The phosphor coating on the face of the CRT has a given useful life and will provide satisfactory performance under normal usage. Since the phosphor efficiency decreases throughout its use at a rate which is a function of the beam intensity, the useful life of the CRT is determined by the application and the usage at high intensities.

Consequently, the continuous use at high brightness, and in particular prolonged use of a fixed pattern at high intensity, will adversely affect the useful life of the CRT. Continuous or repetitive use with a high-intensity fixed pattern will ultimately result in the "etching" of that pattern into the phosphor as a result of accelerated degradation in the area of the pattern. In the case of fixed pattern applications, the life is optimized by repositioning the pattern from time to time or by limiting the brightness when not in active use.

CEILING MOUNT PRECAUTION



In a ceiling-mount application, the strength and rigidity of the ceiling are very important. The location should be carefully checked before hand to determine that the installation will safely support the weight of the system.

NOTE

AmPro CORPORATION IS NOT RESPONSIBLE FOR INJURY OR DAMAGE CAUSED BY AN IMPROPERLY INSTALLED SYSTEM.

SPECIFICATION CHART

SPECIFICATIONS		ESPRIT 2000D	ESPRIT 2000G
Rated Light Output:		650 lumens @ 10% peak white	
CRTs:		7" Liquid-cooled CRTs w/refractive hybrid lenses and focal plane adjustments	
Lenses	Standard	6-element, high resolution, coated, F1.01 with center and edge focusing	
Resolution:	RGB	1280 lines (bandwidth 70MHz. with high speed amplifiers)	
	Video	650 lines	
Screen Size :		4 ft. (1.2m) to 20 ft. (6.1m) picture width	
AutoScan Frequencies: (auto/lock)	Horizontal	15kHz to 56kHz	15kHz to 80kHz
	Vertical	40Hz to 150Hz	40Hz to 150Hz
Minimum Retrace:	Horizontal	< 3 μ sec	
	Vertical	400 μ sec	
Inputs:	Standard	Analog RGB1 Channel	
	Options	(1) TTL (CGA/EGA)/VGA, (2) Quad Video/S-VHS , (3) Analog RGB2,	
Remote Control:	Standard	Full function hard-wired remote control with 25ft. (2.5 m) cable with LCD	
	Option	Infrared Executive, with ON/OFF/STANDBY and 8 Channel select	
Remote Control Operates:		Brightness, contrast, color, tint, detail, size, phasing, raster alignment, Stand-by, On/off, blanking, test patterns and all static and dynamic registration, store and recall of all settings. up to 50 channels of Analog RGB, TTL and Video, Optional 4 or 8 channel switcher with RS-232.	
Feature:		Upgradable to Esprit 2000G	
Special Features:		RS-232 communications for computer control, and networking Four sided blanking with variable picture aspect ratio. Microprocessor-based, modular design for ease of servicing. Operational status and error diagnostic LCD display on the remote control, internal Help Menu with set-up and operating instructions. Remote digital registration.	
Dimensions (H x W x D):		9.9 in. (25.1cm) x 22.5 in. (57.15cm) x 31.5 in. (80 cm)	
Net Weight:		100 lb. (45.5kg)	
Shipping Weight:		150 lb. (68.2kg)	
Part Number:		69203	69202
Operating Ambient Temperature:		+ 32F to 97F (0C to 36C)	
Operating Ambient Humidity:		20% to 80%, Non condensing	
Power Requirements:	110 VAC	90 VAC to 132 VAC 60Hz/50Hz	
	220 VAC	180 VAC to 264 VAC 50 Hz/60Hz	
Maximum Power:		400 Watts	

TABLE 1-1. ESPRIT 2000 D/G SPECIFICATIONS.

2000 D/G SYSTEM DIMENSIONS

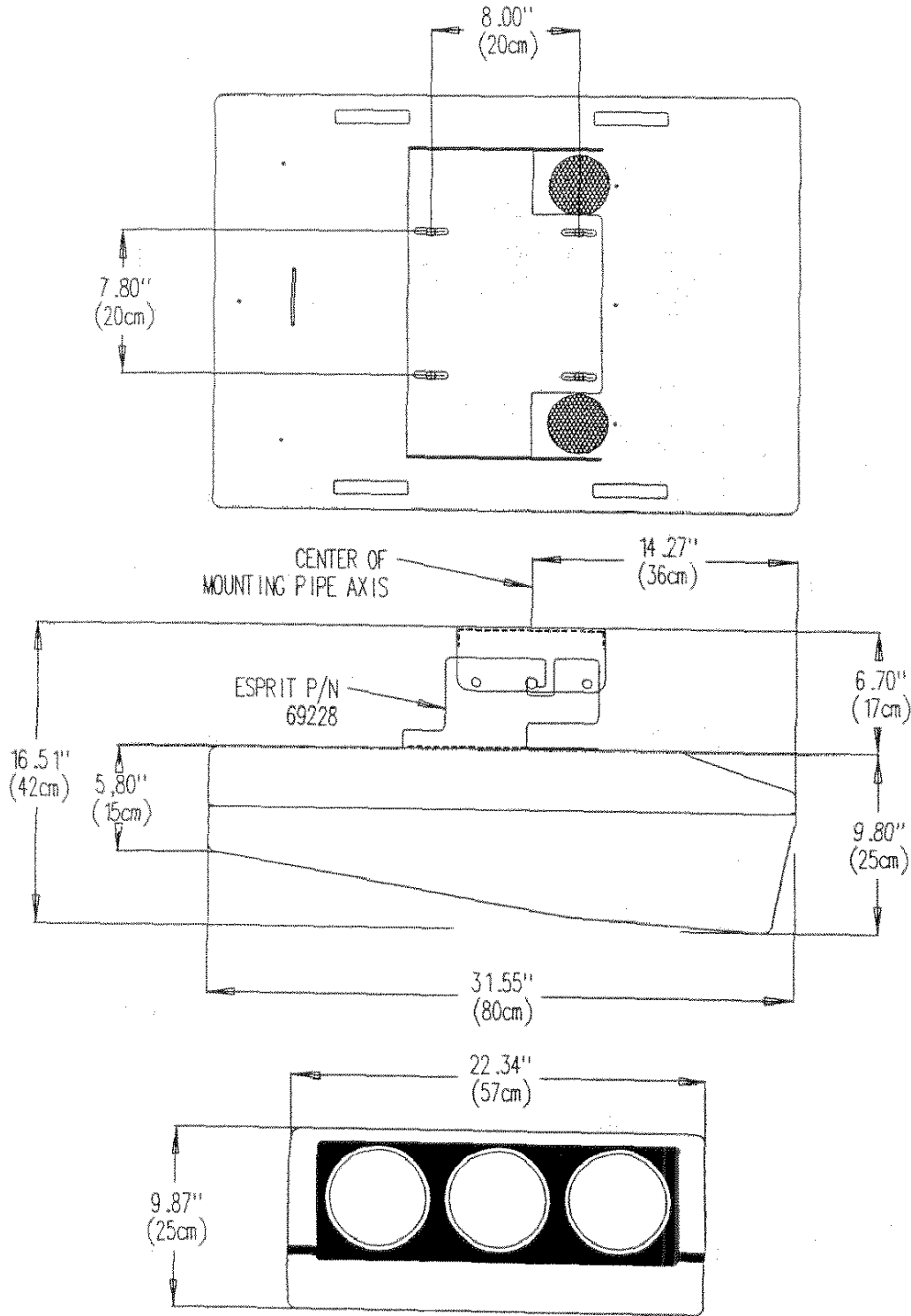

FIGURE 1-1. ESPRIT 2000 D/G SYSTEM DIMENSIONS.

2000 D/G REAR PANEL LAYOUT

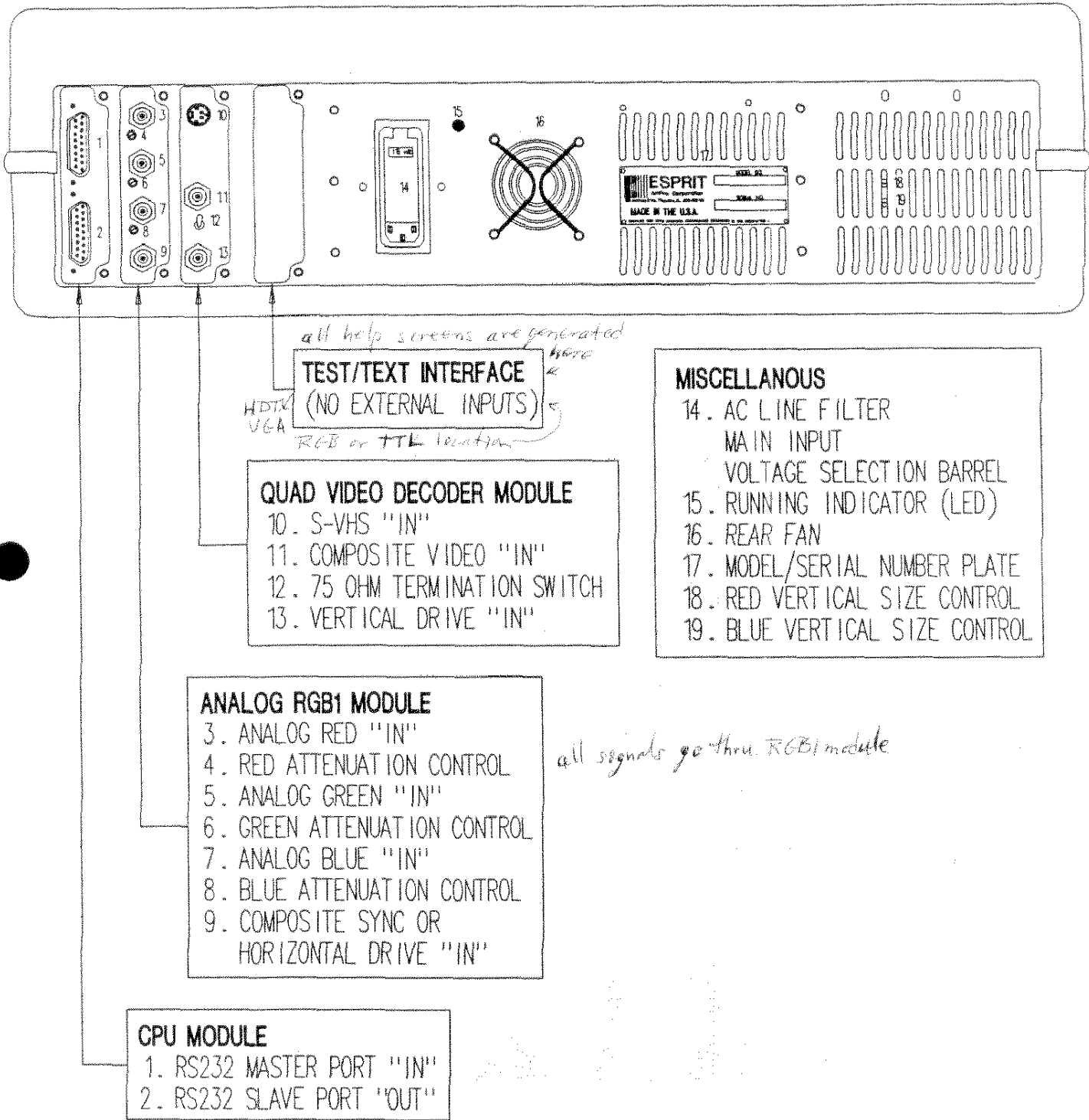

FIGURE 1-2. ESPRIT 2000 D/G REAR PANEL LAYOUT.

FAN FILTERS REMOVAL AND CLEANING

The two filters on the bottom of the system are reusable and are provided to maintain a clean environment within the system. Please check the filters periodically and adjust your cleaning periods accordingly. In areas of heavy dust, smoke, or other environmental contaminants, the system will require more frequent cleaning periods, i.e. weekly, monthly, bimonthly, etc. To remove and clean the filter media, follow the steps listed below.

- STEP 1. Remove the filter retainer by pulling the sides with the catch apart. Refer to Figure 1-3.
- STEP 2. Remove the filter media from between the retainer and the guard. Refer to Figure 1-4.
- STEP 3. Clean the filter media by shaking or blowing. Ensure the filter is as clean as possible. DO NOT WASH.
- STEP 4. Repeat steps 1 through 3 for each filter.
- STEP 5. Place the filter media between the filter guard and the retainer. Push the retainer until the catches lock in place.

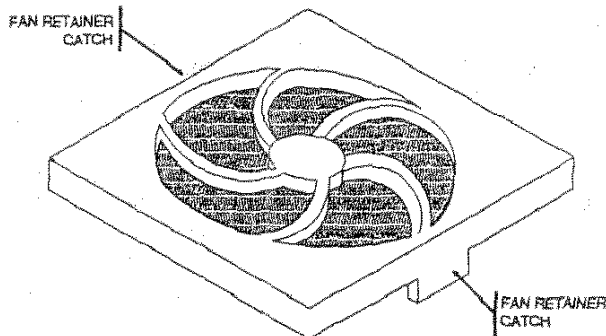

FIGURE 1-3. FAN FILTER RETAINER REMOVAL.

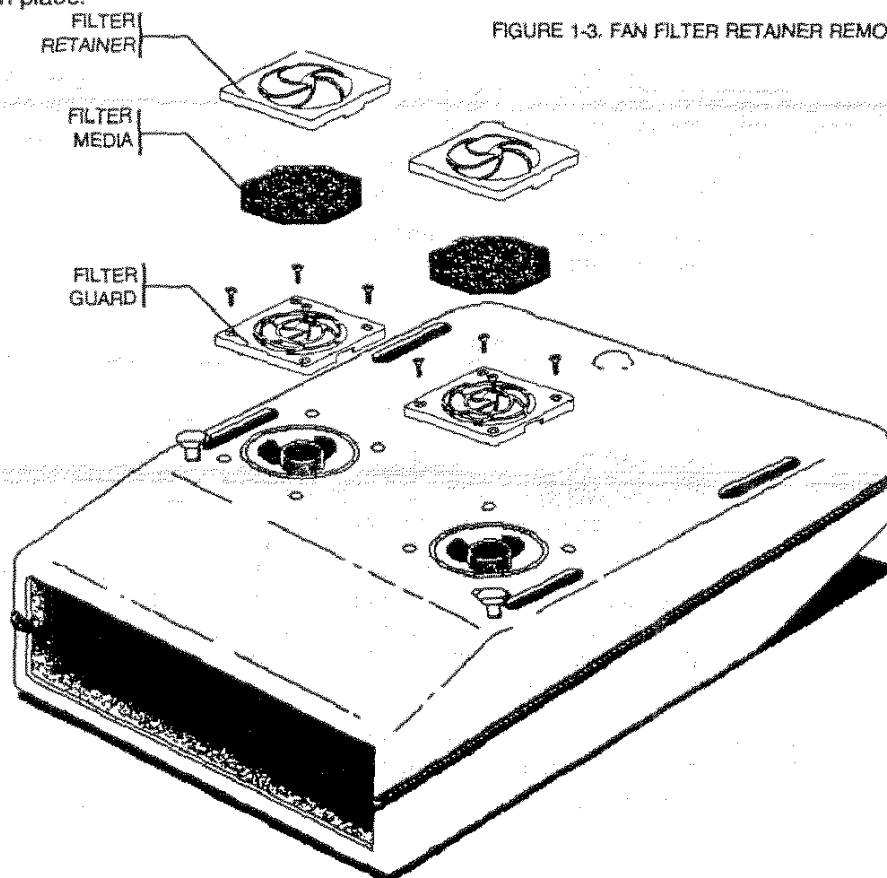

FIGURE 1-4. BOTTOM FAN ASSEMBLIES.

ESPRIT 2000D/G MODULE DESCRIPTIONS

CPU Module

Storage of channel setup data - The CPU has battery backed up memory used for storing the adjustment values for each of the 50 channels. These values are automatically downloaded to digital-to-analog converters located on the registration module of the projector when a new channel is selected.

RS232 Communication - All RS232 serial communication both to and from the projector is processed by the CPU via the HOST and SLAVE ports located at the rear of the projector. Serial data arriving at the projector from the remote control or alternate external control system enters the CPU for processing through the HOST port and is simultaneously echoed through buffers to the SLAVE port to additional projectors or RS232 controlled accessories. Please refer to the ESPRIT 2000 D/G Operation Manual, Chapter 10 for additional information about projector RS232 control and communication.

Diagnostic Routines - The CPU constantly monitors all critical waveforms, voltages and signal levels internal to the projector. Should one of the latter fall below preset limits or disappear altogether, the CPU generates diagnostic messages which are transmitted to the display of the remote control or alternate external control system. Please refer to the ESPRIT 2000 D/G or 4000 D/G Operation Manual, Chapter 11 for additional information about projector diagnostics and trouble shooting.

Quad Decoder Module

Composite and S-Video Input - The quad decoder module accepts both composite video and S-video signals in NTSC 3.58, NTSC 4.43, PAL or SECAM formats. The quad decoder automatically detects the format of the incoming video signal and decodes the signal into its Red, Green, Blue and Sync components which are then passed to the RGB 1 module and sync processor sub-module for further processing (see RGB 1 module, Initial RGB Amplification and Sync Processing).

Vertical Sync (Drive) Input - The quad decoder module accepts a vertical sync input via the V Drive input BNC connector. This input is used when an RGB source with split H and V sync is to be connected to the projector.

RGB 1 Module

Primary RGB Analog Input - The RGB 1 module allows an external RGB source with composite sync, split H and V sync or sync on green to be connected to the projector. In the case of split H and V sync, the V sync is connected to the V Drive input located on the quad decoder module adjacent to the RGB 1 module. Detection of sync format occurs automatically. Multi-turn attenuators serving as primary sub-contrast controls are located next to the red, blue and green BNC connectors.

Initial RGB Amplification - Small signal RGB amplification, DC level control (brightness or black level) and gain control (contrast or picture) of the incoming RGB 1 signal are performed on the RGB 1 module. Decoded RGB signals from the quad decoder module or optional TTL module, VGA module or RGB 2 module are processed by the RGB 1 module as well. The Red, Green and Blue outputs of the RGB 1 module are fed directly to the CRT cards where the signals are amplified to CRT cathode drive levels.

Sync Processing - The sync processor sub-module is mounted to the RGB 1 module. Incoming composite sync signals are split into separate H and V components by the sync processor before being routed to the appropriate deflection circuits of the projector.

Test/Text Module

Test Pattern and Help Menu Text Interface - Located on the test/text module is circuitry used to interface the projector's internally generated test patterns and help menu screens with the RGB 1 module. The test patterns are generated by circuitry on the registration module and the text used in help screens is stored on EPROMs on the CPU module.

Optional Signal Input Modules - Optional signal input modules may be installed in place of the test/text module. These modules include a TTL input module, VGA input module, and analog RGB 2 input module. The optional input modules contain the circuitry normally located on the Test/Text module as well as the circuitry necessary for converting the incoming signal to its Red, Green, Blue and Sync components for processing by the RGB 1 module.

CRT Amplifier Modules

The final amplification and blanking of the red, green and blue signals delivered by the RGB 1 module occurs on the CRT amplifier modules. The CRTs receive their G1 and G2 biasing voltages as well as electrostatic focus voltage from the high voltage power supply via the CRT amplifier modules.

Vertical Deflection Module

Vertical Deflection - The vertical deflection module is used to generate the vertical deflection drive signals supplied to the vertical deflection yokes of the CRTs. The vertical sync signal is delivered to the vertical deflection module from the sync processor sub-module and used to drive power transistors which, in turn, drive the vertical deflection yokes. If no incoming vertical sync signal is present, the vertical deflection module will default to a self-generated 40 Hz vertical sync.

Sweep (Deflection) Fail Detection - The sweep fail detection circuitry is located on the vertical deflection module. This circuit is designed to detect the failure of vertical and/or horizontal deflection and react by immediately shutting off the G2 voltage supply to the CRTs, effectively cutting off the CRT beam current to avoid burning the CRTs phosphor surfaces.

Other functions of the vertical deflection module include control of master vertical size, shift, phase and static red and blue vertical shifts, static east-west keystone and pincushion adjustments. In addition, the vertical deflection module generates the vertical reset pulse which is used by the registration module to properly phase the vertical registration waveforms with the vertical deflection drive signals.

Horizontal Deflection Module

Horizontal Deflection Control - The horizontal deflection module converts the horizontal sync pulse delivered by the sync processor sub-module into a signal suitable to drive the horizontal deflection switching MOSFETs located on the H.O.T. module. If no incoming horizontal sync signal is present, the horizontal deflection module will default to a self-generated 15 kHz horizontal sync. In addition, the horizontal deflection module generates the horizontal reset pulse which is used by the registration module to properly phase the horizontal registration waveforms with the horizontal deflection drive signals.

Horizontal Linearity, Retrace Time and Phase Control - The horizontal deflection module controls the H.O.T. module in order to optimize horizontal image linearity and deflection retrace time for the entire horizontal frequency range of the projector. In addition, the horizontal phase control signal from the CPU is received by the horizontal deflection module and used to control the deflection vs. signal phase timing of the H.O.T. module.

H.O.T. Module

Horizontal Deflection - The H.O.T. module uses the control signals received from the horizontal deflection module to create the horizontal deflection drive signals supplied to the horizontal deflection yokes of the CRTs.

East-West Correction - The static keystone and pincushion signals generated by the vertical deflection module are delivered to the H.O.T. module and used to modulate the horizontal size of the projected image during the vertical sweep.

Switch Mode Power Supply Module

The switch mode power supply generates the low level DC supply voltages used to power the projector's various modules. A separate high voltage power supply is used to generate the voltages required to bias the projector's CRTs.

The switch mode power supply accepts either a 110V or 220V AC line input operating at 50 or 60 Hz. This AC input is rectified and switched across the primary winding of a transformer. The various DC voltages produced by the switch mode power supply are derived from the filtered outputs of secondary windings of the transformer. The DC outputs of the switch mode power supply are fused and also indicated by LEDs located on the upper cover of the module. These voltages are also monitored by the CPU module's diagnostic routines (see CPU Module, Diagnostic Routines).

High Voltage Power Supply Module

The high voltage power supply module is used to generate the 34kV CRT anode voltage supply, 10kV CRT focus grid voltage supply, 800V CRT G2 voltage supply and CRT G1 voltage supply. The electrostatic focus adjustments for the red, green and blue CRTs are located on the upper cover of the high voltage power supply module. The high voltage power supply is a switch mode type power supply which utilizes multiplying circuitry to amplify the secondary voltage output to the various levels required by the CRTs.

Registration Module

Dynamic Image Geometry and Convergence Adjustments - All dynamic (not static) image geometry and convergence adjustments are controlled by digital-to-analog converters located on the registration module. Channel specific values are downloaded to these DACs from the CPU's battery backed-up memory as channels are selected by the user (see CPU Storage of Channel Setup Data). The DACs are used to control the amplitude of various waveforms which are summed to produce composite red, green and blue registration control waveforms. The phasing of these waveforms is controlled by the horizontal and vertical reset pulses generated by the horizontal and vertical deflection modules.

Test Pattern Generation - All internal projector test and setup patterns are generated by circuitry on the registration module and delivered to the RGB 1 module via the test/text module (see Test/Text Module).

Registration Amplifier Module

Final amplification of the red, green and blue composite registration control waveforms is performed by the registration amplifier module. The amplified composite registration waveforms are delivered to the registration or convergence yokes of the CRTs by the registration amplifier module.

SYSTEM TROUBLE SHOOTING

ERROR MESSAGES

The ESPRIT systems provide two sets of diagnostics messages which are displayed on the LCD read-out located on the standard hard-wired remote control to provide information about the projector mode and operational status.

One set of error messages that may be displayed are mode status error messages. Mode status error messages indicate a wrong function has been selected for the current mode of operation or the selected function can not be entered. An example of a mode status error message is as follows. When a particular channel number has been selected and an attempt to adjust brightness is made, an error message "WRITE PROTECTED" is displayed. This error message refers to a particular channel location and that the parameters of this channel has been established and placed inactive to avoid unwanted adjustments. Refer to Tables 1-2A, 1-2B and 1-2C for additional mode status error messages.

The second set of error messages provided are operational status messages. This type of message provides information about the projector in case of a malfunction for either a voltage or wave form error.

When the system is connected to an active A.C. source and the rocker switch on the rear panel is turned on, the LCD will display "ESPRIT 2000D" or "ESPRIT 2000G" as the case may be. When the POWER button on the remote control is pressed, the system's LCD read-out will display "INITIALIZING," then display the last mode of operation used when the system was de-energized, if there are no malfunctions.

If there is a malfunction of the equipment the system will display an error message. An example of the sequence of messages you would get if the -20V rail was missing is as follows. After the power button on the remote control is pressed, the first read-out would be "INITIALIZING" then "-20 VOLTS LO". This error process continues to cycle through all error messages applicable.

If for some reason the system has been turned on, the desired mode of operation has been selected and the appropriate source is active; however, no image is being projected and there are no diagnostic error messages being displayed on the LCD, use the enable status command 30 CODE. Refer to Page 1-14 for additional operational status error messages.

MODE STATUS ERROR MESSAGES

ERROR MESSAGE	POSSIBLE CAUSE	SOLUTION
AUTO RESTART	System has momentarily loss A.C. line voltage or system was de-energized by main rocker switch.	System should power up as normal.
BAD NUMERIC CODE	Numeric code outside of range entered.	Enter numeric code within range. (10-79,909) Refer to Chapter 7 ¹ , section 17.
BAD TTL MODE	TTL mode of operation outside of range entered .	Enter proper mode of operation.

TABLE 1-2A. MODE STATUS ERROR MESSAGES.

¹REFER TO ESPRIT 2000 D/G OPERATION MANUAL

MODE STATUS ERROR MESSAGES (CONTINUED)

ERROR MESSAGE	POSSIBLE CAUSE	SOLUTION
BAD VIDEO MODE	Video mode of operation outside of range entered.	Refer to Chapter 7 ¹ , section 16 for desired mode of operation.
CHOOSE EDGE	Wrong area of adjustment selected for desired function.	Refer to Chapter 7 ¹ , desired function.
DYNAMIC FUNCTION	Wrong operation for selected function.	Refer to Chapter 7 ¹ , desired function.
ERROR # AT # (I ² C ERROR) (COMMUNICATION FAILURE)	Communication failure between internal modules.	Contact a service technician
ERROR CODE 1000	Call factory	Call factory
ERROR CODE 1001	Call factory	Call factory
ERROR CODE 1002	Call factory	Call factory
HI BEAM CURRENT	CRT protection mode of operation.	Toggle main power rocker switch OFF/ON. Restart system. If continuous, contact the factory.
HVPS RESTART	Momentary protection from high voltage arcing occurred.	If continuous, contact the factory.
HVPS SHUTDOWN	Loss of high voltage occurred.	Contact the factory for assistance
INVALID	Unrecognized command	Retry command.
INVALID CHANNEL	Channel number outside of range (1-50) entered.	Enter channel number within range.
INVALID TEST	Test number outside of range entered.	Refer to Chapter 7, section 12.
INVALID TIME	Time outside of range entered.	Enter time within range (24 hour clock)
INVALID VALUE	Value outside of range (0-100) entered.	Enter value of 0-100.

TABLE 1-2B. MODE STATUS ERROR MESSAGES.

MODE STATUS ERROR MESSAGES (CONTINUED)

ERROR MESSAGE	POSSIBLE CAUSE	SOLUTION
KEYS DISABLED	Registration adjustments are being attempted with "lock-out" feature activated.	To enable registration keys, enter 46 CODE.
MEMORY FAILURE	Loss of data occurred.	Re-enter all settings, channel numbers, registration settings, etc.
MUST BE IN NTSC	Function entered operates in the NTSC modes only.	Refer to Chapter 7 ¹ , section 5-10, page 7-6
MUST BE IN RGB	Function entered pertains to the RGB mode of operation only.	Enter RGB and retry function.
MUST BE IN VIDEO	Function entered operates in the Video modes of operation only.	Refer to chapter 7 ¹ , section 5-10, page 7-6
NOT INSTALLED	Optional mode selected with no optional module installed.	Refer to Chapter 1 ¹ , section 1.1.1 or 1.1.6
OPEN INTERLOCK	Missing or loose module connector Install.	Verify or re-seat all modules/ connectors.
OVER FREQUENCY	Source selected outside of specified frequency range.	Refer Chapter 1 ¹ , table 1.
RED OR BLUE ONLY	Wrong area of adjustment selected for desired color.	Refer to Chapter 7 ¹ , desired function.
RIGHT OR LEFT ONLY	Wrong area of adjustment selected for desired function.	Refer to Chapter 7 ¹ , desired function.
SELECT QUADRANT	Wrong area of adjustment selected for desired function.	Refer to Chapter 7 ¹ , desired function.
WRITE PROTECTED	Attempts to adjust predetermined parameters are being made to a channel location.	Refer to Chapter 7 ¹ section 17.

TABLE 1-2C. MODE STATUS ERROR MESSAGES.

¹REFER TO ESPRIT 2000 D/G OPERATION MANUAL

OPERATIONAL STATUS ERROR MESSAGES

HI OR LOW VOLTAGE ERROR MESSAGES

If any of the following error messages are displayed check origination point, and if required contact the factory for assistance.

MESSAGE	GENERATED BY	PRIMARYLY USED BY
-9 VOLTS	SMPS	VERTICAL DEFLECTION, (ALL MODULES)
+9 VOLTS	SMPS	VERTICAL DEFLECTION, (ALL MODULES)
+40 VOLTS	SMPS	H.O.T. MODULE, CPU
+190 VOLTS	SMPS	CRT AMPLIFIERS, H.O.T. MODULE, CPU
HIGH VOLTAGE	HVPS	CRT ANODES
GRID 2	HVPS	CRT AMPLIFIERS (SOCKET TO CRTS), VERTICAL DEFL.

WAVE FORM ERROR MESSAGES

If any one of the following wave form error messages are displayed, check the diagnostics point, and if required contact the factory for assistance.

"NO INPUT"

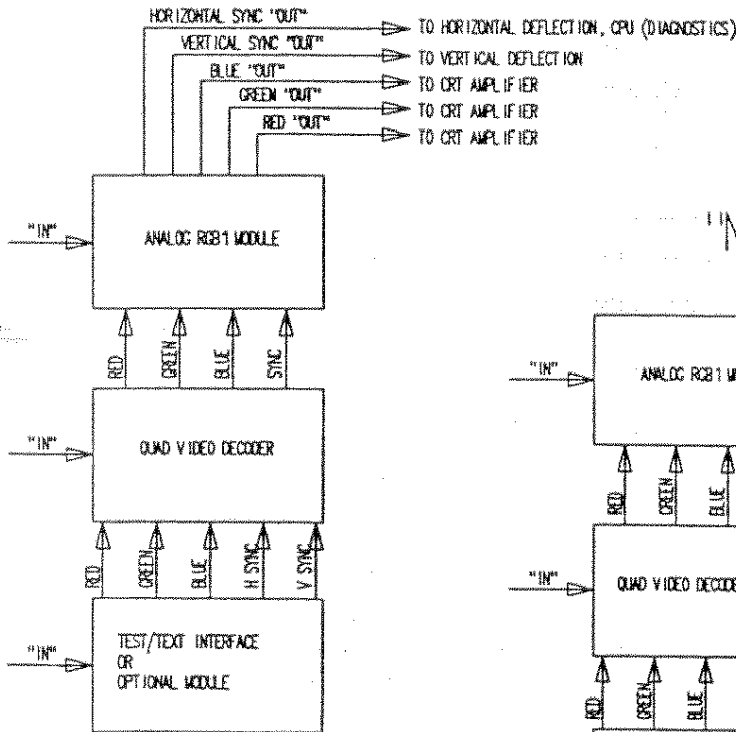

"NO VERT SYNC"

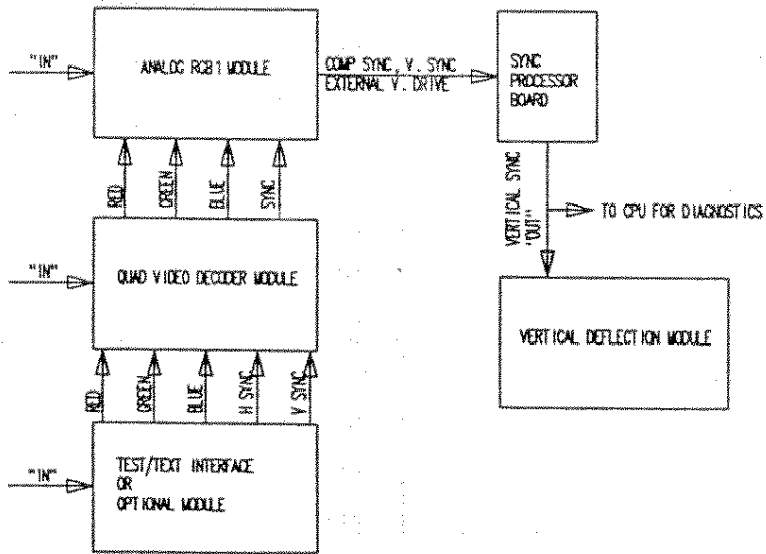

WAVE FORM ERROR MESSAGES (continued)

"H SWEEP FAIL"

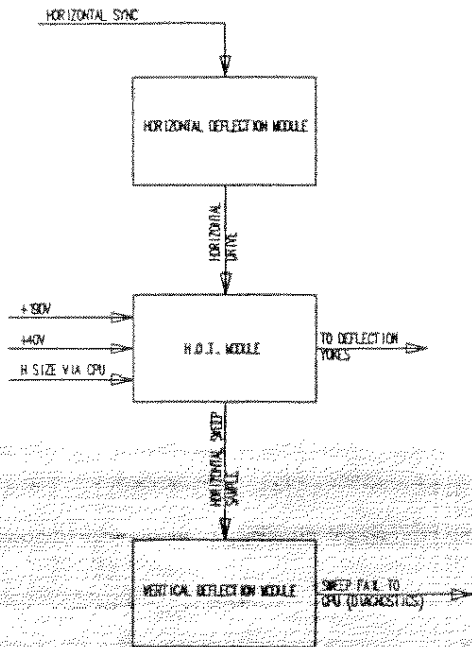

"V SWEEP FAIL"

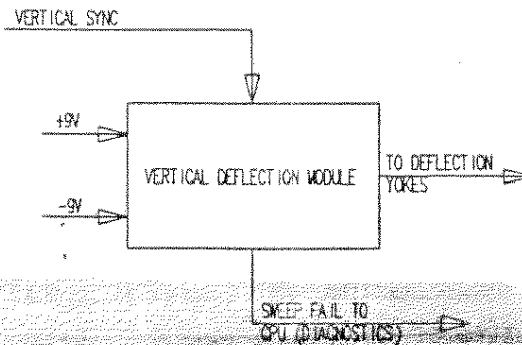

"NO H RESET"

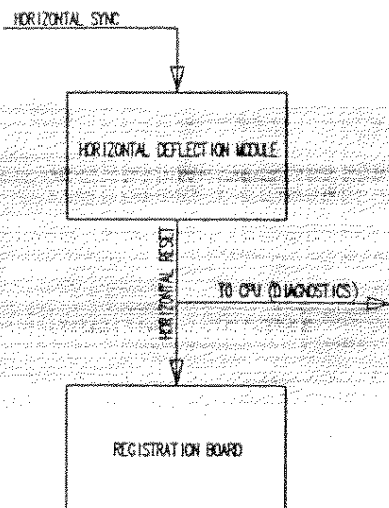

"NO V RESET"

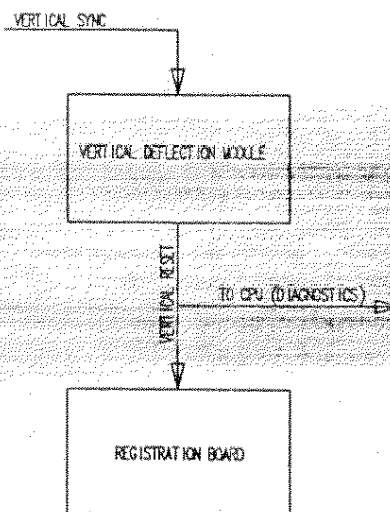

"G1 FAIL LOW"

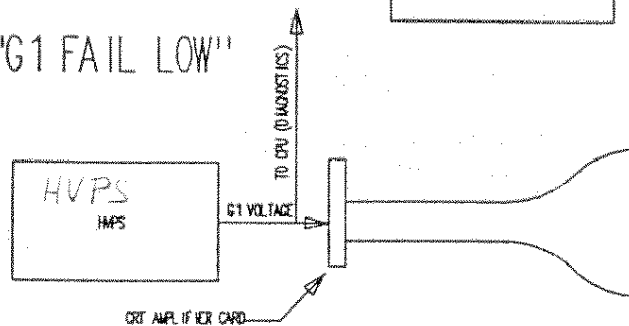

LED ERROR INDICATORS

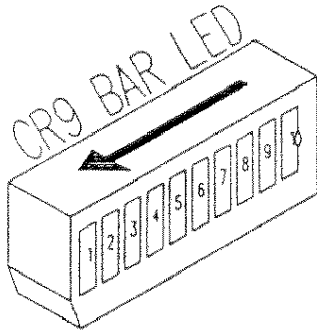

- | LED | FUNCTION |
|-----|------------------------------------|
| 1 | HIGH VOLTAGE FAIL |
| 2 | REMOTE CONTROL RS232 FAULT |
| 3 | I ² C FAULT |
| 4 | I ² C ACTIVE (FLASHING) |
| 5 | MONOCHROME "ON" |
| 6 | CLEAR TO SEND (CTS) |
| 7 | REQUEST TO SEND (RTS) |
| 8 | +12V ALWAYS (ON) |
| 9 | +5V ALWAYS (ON) |
| 10 | UNUSED |

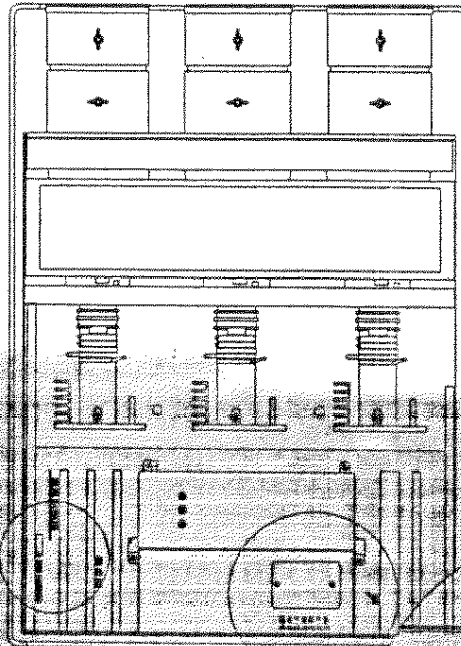

CR9
BAR LED

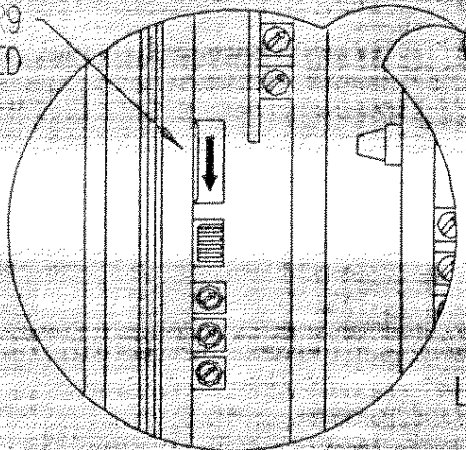

LOW VOLTAGE LEDS (GREEN)
(NORMALLY ALL "ON")

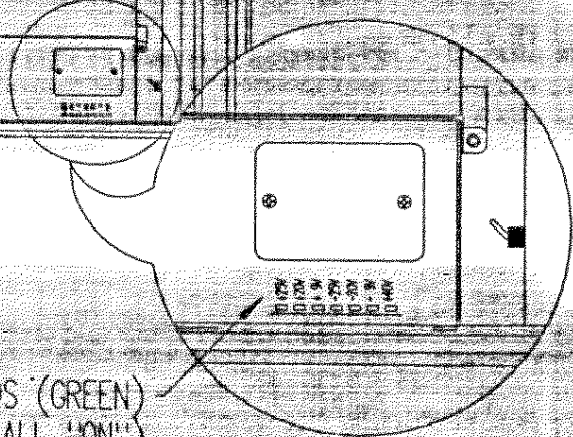

SERVICING POLICY

Repair of the ESPRIT modular designed systems shall be accomplished exclusively through a factory sub-assembly module exchange program. Servicing by a ESPRIT PROJECTION SYSTEMS Service Center or by an ESPRIT PROJECTION SYSTEMS selling dealer, is limited to failure diagnostics, registration alignment, and replacement of CRT assemblies, lenses, and sub-assembly modules.

No material and/or labor credit will be granted for an exchange sub-assembly, if it has been repaired, reworked or modified. The warranty is voided if a repair, rework and/or modification of a sub-assembly module is performed other than by ESPRIT PROJECTION SYSTEMS.

To return a sub-assembly module for exchange a Return Authorization number (RA number) must be obtained from the ESPRIT PROJECTION SYSTEMS Customer Service Department. To obtain an RA number for exchange of a sub-assembly module it will be necessary to have the particular symptom, model number and serial number of the system available for the Customer Service Representative.

SECTION 2

SCHEMATICS/BLOCK DIAGRAMS

DESCRIPTION	PART NUMBER	REV. LEVEL	PAGE
MOTHER BOARD INTERCONNECT	80860	X1	2-1
I ² C CPU MODULE	80857	X4	2-4
I ² C ADDRESS GUIDE	N/A	A	2-9
QUAD DECODER W/S-VHS ¹	80779	B	2-10
VIDEO SELECT BOARD ¹	80780	C	2-13
ANALOG RGB1 MODULE ²	80881	X1	2-14
SYNC PROCESSOR ²	80734	G	2-17
TTL MODULE	80715	X3	2-18
ANALOG RGB2 MODULE	80786	X2	2-20
TEST/TEXT INTERFACE MODULE	80785	X	2-23
CRT AMPLIFIER CARD	80880	B	2-25
VERTICAL DEFLECTION MODULE	80833	A	2-27
2000G HORIZ DEFLECTION MODULE	80732	A	2-30
2000D HORIZ DEFLECTION MODULE	80762	X7	2-33
H.O.T MODULE	80781	X4	2-35
YOKE BOARD	80746	X	2-37
SMPS (SWITCH MODE POWER SUPPLY) ³	80725	B	2-38
SMPS REGULATOR BOARD ³	80742	X1	2-40
HYBRID REGISTRATION BOARD ⁴	80702	B	2-41
REGISTRATION MUX BOARD ⁴	80811	X	2-53
REGISTRATION VERTICAL FILTER BD. ⁴	80802	X	2-56
REGISTRATION AMPLIFIER BOARD	80735	X	2-57
FOCUS MODULATOR	80755	A	2-58

NOTES:

1. PART OF QUAD VIDEO DECODER ASSEMBLY P/N: 69127
2. PART OF RGB1 ASSEMBLY P/N: 80881
3. PART OF SMPS ASSEMBLY P/N: 80725
4. PART OF REGISTRATION ASSEMBLY P/N: 80702

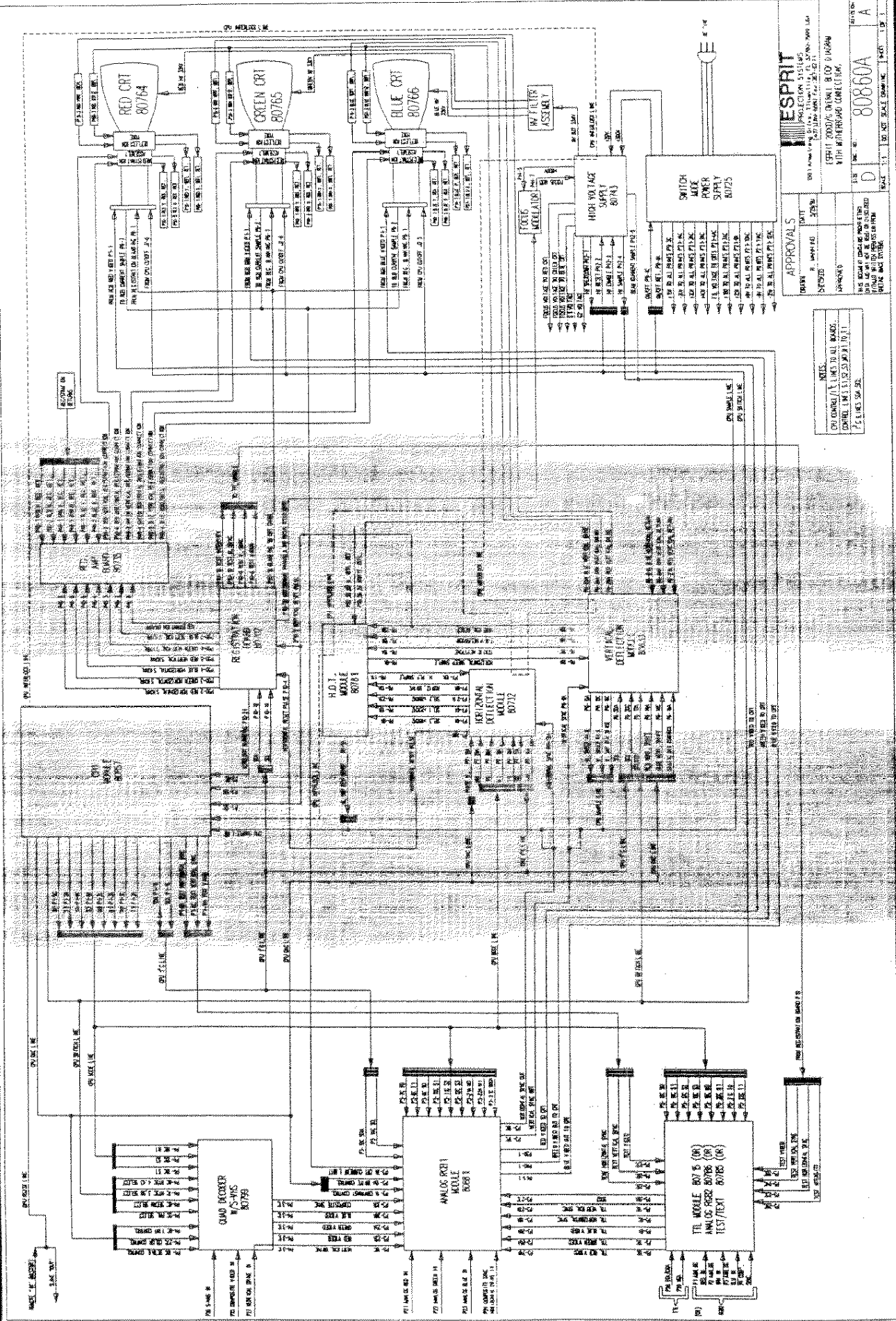

ESPRIT PROJECTION SYSTEMS
 6701 KENNEDY BLVD., FORT WORTH, TEXAS 76109-1508
 (817) 343-5000 FAX (817) 343-5001

ESPRIT 2000D/G INTERNAL BLOCK DIAGRAM WITH INTERBOARD CONNECTIONS

REV. NO.	D	REV. DATE	03/10/91
REV. BY	DAVID	REV. DATE	03/10/91
REV. BY	DAVID	REV. DATE	03/10/91

APPROVALS

DESIGNER	R. HAYES
DESIGNED BY	DAVID
CHECKED BY	DAVID
DATE	03/10/91

80860A

NOTES:
 CPU CONTROL LINES IN ALL BLOCKS.
 CONTROL LINES IN 1, 2, 3, 4, 5, 6, 7, 8, 9, 10, 11, 12, 13, 14, 15, 16, 17, 18, 19, 20, 21, 22, 23, 24, 25, 26, 27, 28, 29, 30, 31, 32, 33, 34, 35, 36, 37, 38, 39, 40, 41, 42, 43, 44, 45, 46, 47, 48, 49, 50, 51, 52, 53, 54, 55, 56, 57, 58, 59, 60, 61, 62, 63, 64, 65, 66, 67, 68, 69, 70, 71, 72, 73, 74, 75, 76, 77, 78, 79, 80, 81, 82, 83, 84, 85, 86, 87, 88, 89, 90, 91, 92, 93, 94, 95, 96, 97, 98, 99, 100, 101, 102, 103, 104, 105, 106, 107, 108, 109, 110, 111, 112, 113, 114, 115, 116, 117, 118, 119, 120, 121, 122, 123, 124, 125, 126, 127, 128, 129, 130, 131, 132, 133, 134, 135, 136, 137, 138, 139, 140, 141, 142, 143, 144, 145, 146, 147, 148, 149, 150, 151, 152, 153, 154, 155, 156, 157, 158, 159, 160, 161, 162, 163, 164, 165, 166, 167, 168, 169, 170, 171, 172, 173, 174, 175, 176, 177, 178, 179, 180, 181, 182, 183, 184, 185, 186, 187, 188, 189, 190, 191, 192, 193, 194, 195, 196, 197, 198, 199, 200, 201, 202, 203, 204, 205, 206, 207, 208, 209, 210, 211, 212, 213, 214, 215, 216, 217, 218, 219, 220, 221, 222, 223, 224, 225, 226, 227, 228, 229, 230, 231, 232, 233, 234, 235, 236, 237, 238, 239, 240, 241, 242, 243, 244, 245, 246, 247, 248, 249, 250, 251, 252, 253, 254, 255, 256, 257, 258, 259, 260, 261, 262, 263, 264, 265, 266, 267, 268, 269, 270, 271, 272, 273, 274, 275, 276, 277, 278, 279, 280, 281, 282, 283, 284, 285, 286, 287, 288, 289, 290, 291, 292, 293, 294, 295, 296, 297, 298, 299, 300, 301, 302, 303, 304, 305, 306, 307, 308, 309, 310, 311, 312, 313, 314, 315, 316, 317, 318, 319, 320, 321, 322, 323, 324, 325, 326, 327, 328, 329, 330, 331, 332, 333, 334, 335, 336, 337, 338, 339, 340, 341, 342, 343, 344, 345, 346, 347, 348, 349, 350, 351, 352, 353, 354, 355, 356, 357, 358, 359, 360, 361, 362, 363, 364, 365, 366, 367, 368, 369, 370, 371, 372, 373, 374, 375, 376, 377, 378, 379, 380, 381, 382, 383, 384, 385, 386, 387, 388, 389, 390, 391, 392, 393, 394, 395, 396, 397, 398, 399, 400, 401, 402, 403, 404, 405, 406, 407, 408, 409, 410, 411, 412, 413, 414, 415, 416, 417, 418, 419, 420, 421, 422, 423, 424, 425, 426, 427, 428, 429, 430, 431, 432, 433, 434, 435, 436, 437, 438, 439, 440, 441, 442, 443, 444, 445, 446, 447, 448, 449, 450, 451, 452, 453, 454, 455, 456, 457, 458, 459, 460, 461, 462, 463, 464, 465, 466, 467, 468, 469, 470, 471, 472, 473, 474, 475, 476, 477, 478, 479, 480, 481, 482, 483, 484, 485, 486, 487, 488, 489, 490, 491, 492, 493, 494, 495, 496, 497, 498, 499, 500, 501, 502, 503, 504, 505, 506, 507, 508, 509, 510, 511, 512, 513, 514, 515, 516, 517, 518, 519, 520, 521, 522, 523, 524, 525, 526, 527, 528, 529, 530, 531, 532, 533, 534, 535, 536, 537, 538, 539, 540, 541, 542, 543, 544, 545, 546, 547, 548, 549, 550, 551, 552, 553, 554, 555, 556, 557, 558, 559, 560, 561, 562, 563, 564, 565, 566, 567, 568, 569, 570, 571, 572, 573, 574, 575, 576, 577, 578, 579, 580, 581, 582, 583, 584, 585, 586, 587, 588, 589, 590, 591, 592, 593, 594, 595, 596, 597, 598, 599, 600, 601, 602, 603, 604, 605, 606, 607, 608, 609, 610, 611, 612, 613, 614, 615, 616, 617, 618, 619, 620, 621, 622, 623, 624, 625, 626, 627, 628, 629, 630, 631, 632, 633, 634, 635, 636, 637, 638, 639, 640, 641, 642, 643, 644, 645, 646, 647, 648, 649, 650, 651, 652, 653, 654, 655, 656, 657, 658, 659, 660, 661, 662, 663, 664, 665, 666, 667, 668, 669, 670, 671, 672, 673, 674, 675, 676, 677, 678, 679, 680, 681, 682, 683, 684, 685, 686, 687, 688, 689, 690, 691, 692, 693, 694, 695, 696, 697, 698, 699, 700, 701, 702, 703, 704, 705, 706, 707, 708, 709, 710, 711, 712, 713, 714, 715, 716, 717, 718, 719, 720, 721, 722, 723, 724, 725, 726, 727, 728, 729, 730, 731, 732, 733, 734, 735, 736, 737, 738, 739, 740, 741, 742, 743, 744, 745, 746, 747, 748, 749, 750, 751, 752, 753, 754, 755, 756, 757, 758, 759, 760, 761, 762, 763, 764, 765, 766, 767, 768, 769, 770, 771, 772, 773, 774, 775, 776, 777, 778, 779, 780, 781, 782, 783, 784, 785, 786, 787, 788, 789, 790, 791, 792, 793, 794, 795, 796, 797, 798, 799, 800, 801, 802, 803, 804, 805, 806, 807, 808, 809, 810, 811, 812, 813, 814, 815, 816, 817, 818, 819, 820, 821, 822, 823, 824, 825, 826, 827, 828, 829, 830, 831, 832, 833, 834, 835, 836, 837, 838, 839, 840, 841, 842, 843, 844, 845, 846, 847, 848, 849, 850, 851, 852, 853, 854, 855, 856, 857, 858, 859, 860, 861, 862, 863, 864, 865, 866, 867, 868, 869, 870, 871, 872, 873, 874, 875, 876, 877, 878, 879, 880, 881, 882, 883, 884, 885, 886, 887, 888, 889, 890, 891, 892, 893, 894, 895, 896, 897, 898, 899, 900, 901, 902, 903, 904, 905, 906, 907, 908, 909, 910, 911, 912, 913, 914, 915, 916, 917, 918, 919, 920, 921, 922, 923, 924, 925, 926, 927, 928, 929, 930, 931, 932, 933, 934, 935, 936, 937, 938, 939, 940, 941, 942, 943, 944, 945, 946, 947, 948, 949, 950, 951, 952, 953, 954, 955, 956, 957, 958, 959, 960, 961, 962, 963, 964, 965, 966, 967, 968, 969, 970, 971, 972, 973, 974, 975, 976, 977, 978, 979, 980, 981, 982, 983, 984, 985, 986, 987, 988, 989, 990, 991, 992, 993, 994, 995, 996, 997, 998, 999, 1000

MOTHER BOARD INTERCONNECT (80860X1) BLOCK DIAGRAM

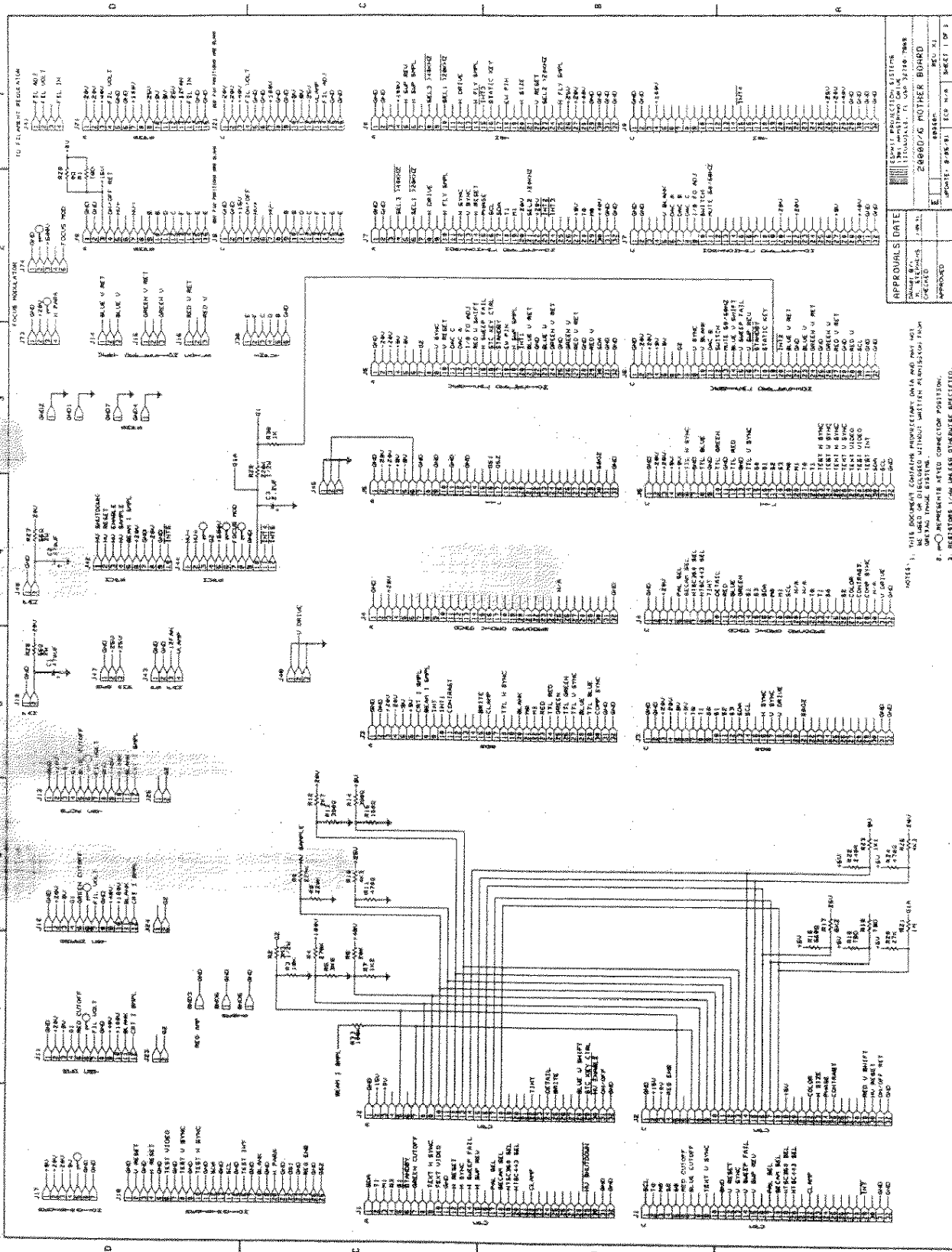

APPROVALS	DATE	DESIGN PROJECTION SYSTEMS
DESIGNED		1784433700 004 311607888
CHECKED		28880/G MOTHER BOARD
APPROVED		ISSUED
		APPROVED
		DESIGNER
		DATE
		PROJECT
		SHEET NO.
		TOTAL SHEETS

NOTES: 1. THIS DOCUMENT CONTAINS PROPRIETARY DATA AND MAY NOT BE REPRODUCED OR TRANSMITTED IN ANY FORM OR BY ANY MEANS, ELECTRONIC OR MECHANICAL, INCLUDING PHOTOCOPYING, RECORDING, OR BY ANY INFORMATION STORAGE AND RETRIEVAL SYSTEM.
 2. DIMENSIONS ARE AT CONNECTION POSITION.
 3. RESISTORS 1-WH UNLESS OTHERWISE SPECIFIED.

MOTHER BOARD INTERCONNECT (80860X1) SCHEMATIC 1 of 1

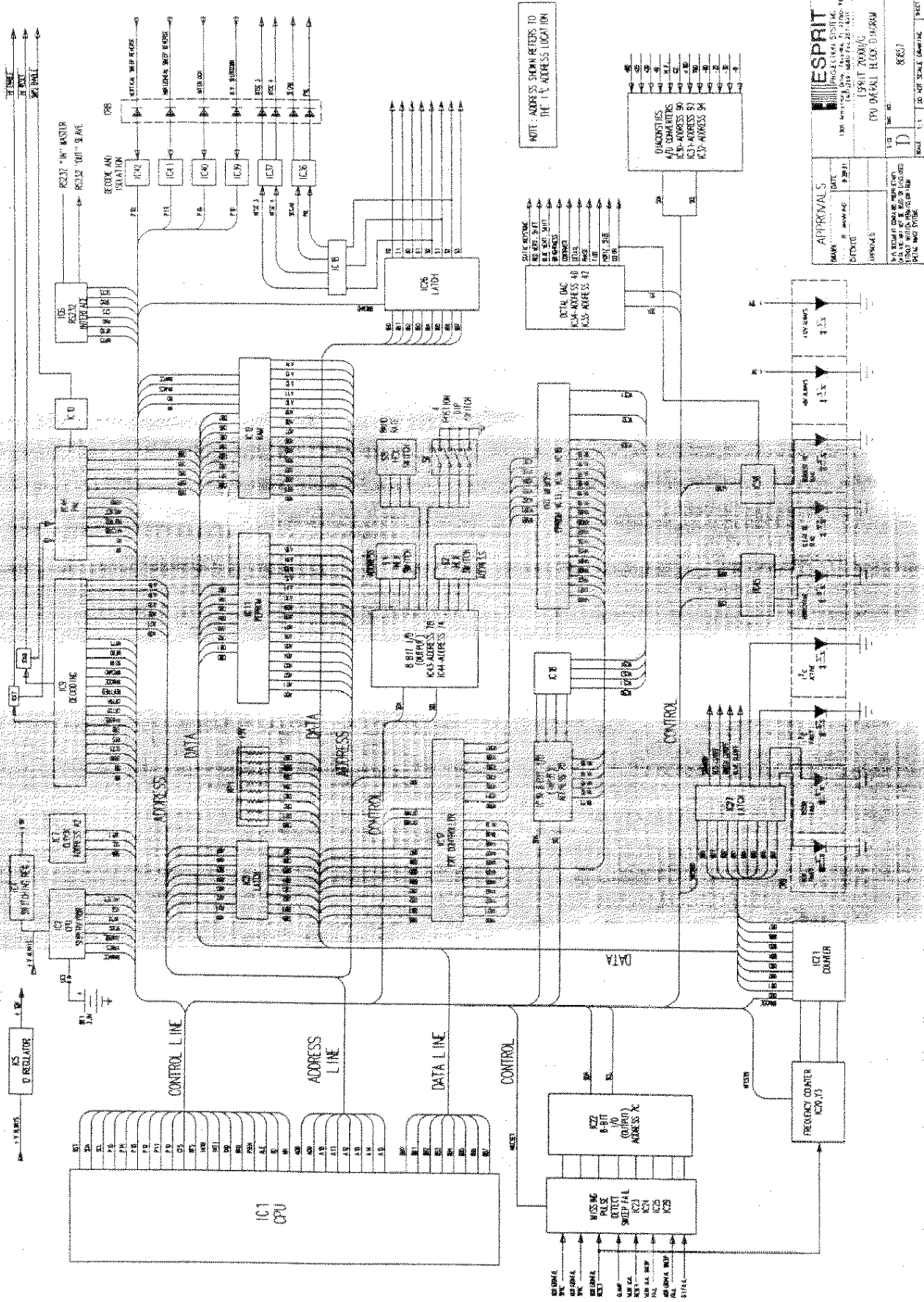

CPU MODULE (80587X4) BLOCK DIAGRAM

ESPRIT
 PROGRAMS SYSTEM
 1981 7000A
 CPU MODULE BLOCK DIAGRAM

APPROVALS
 MARK: [] DATE: []
 DESIGNED BY: []
 CHECKED BY: []
 APPROVED BY: []

DATE: [] TIME: []
 SHEET: [] OF []

NOTE: ADDRESS SHOWN REFERS TO THE I/O ADDRESS LOCATION

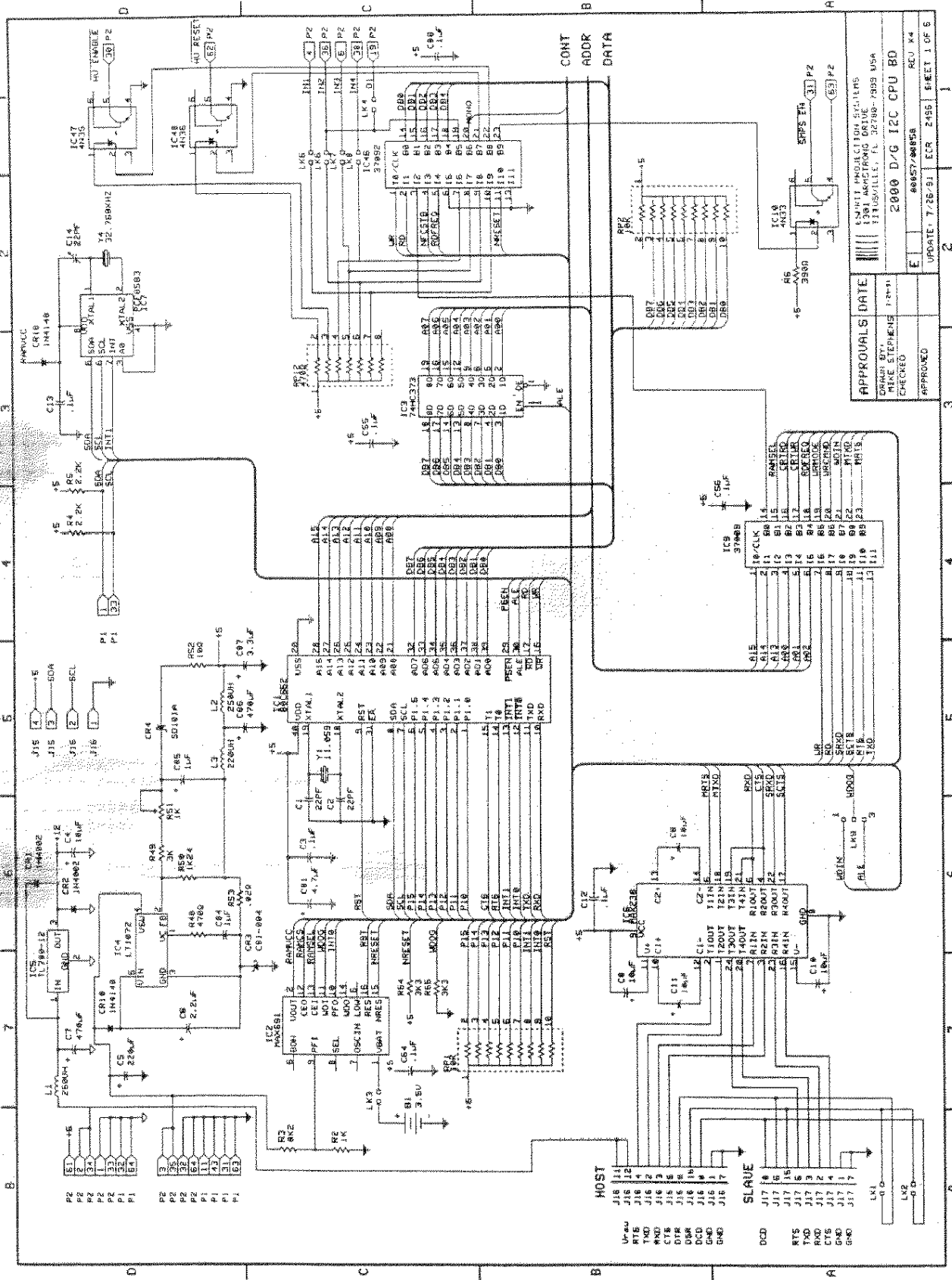

CPU MODULE (80587X4) SCHEMATIC 1 of 5

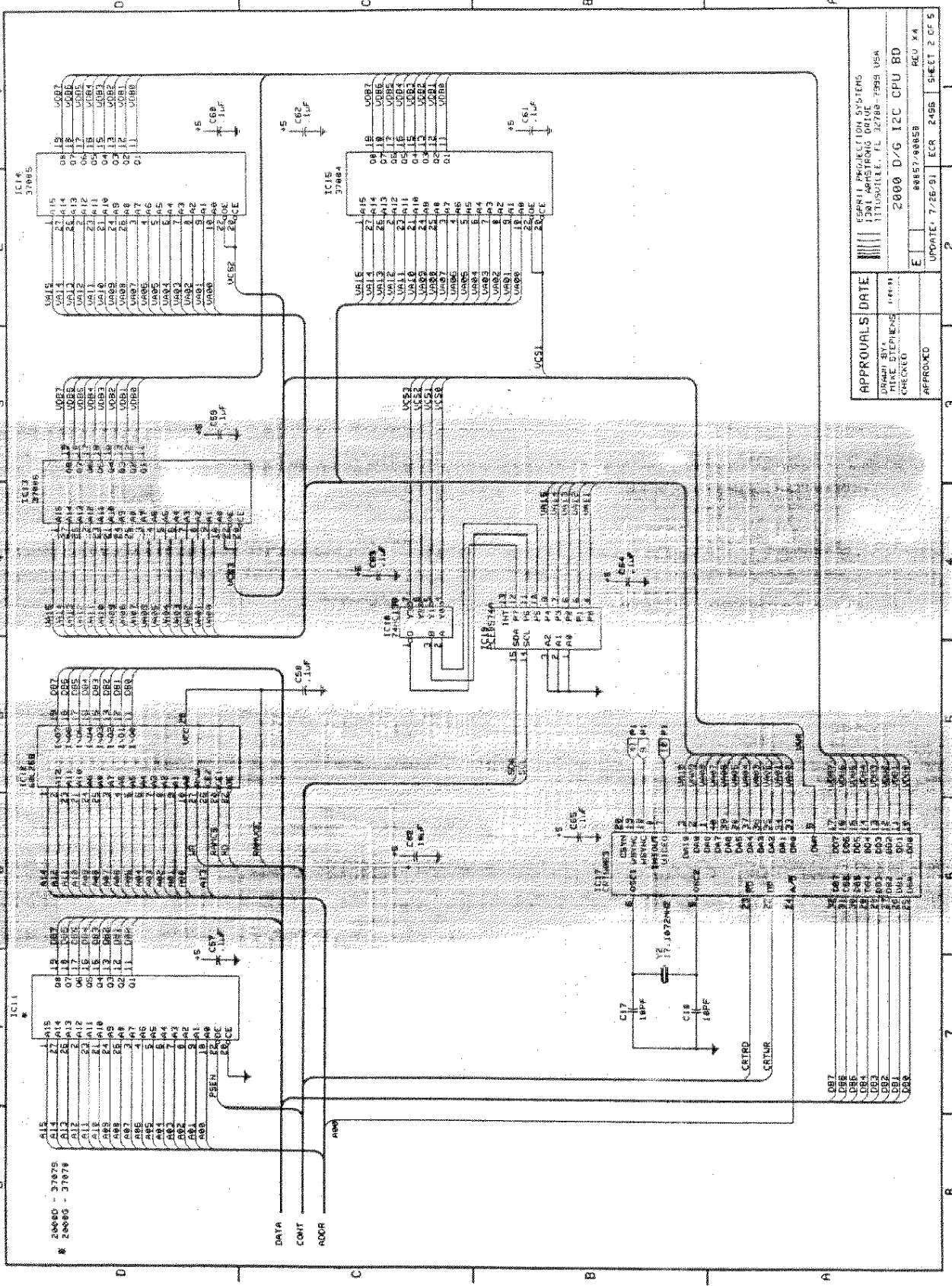

APPROVALS	DATE	ESPRIT PRODUCTION SYSTEMS 1381 APPELBOURG RD MILWAUKEE, WI 53219-7998 USA
DESIGNED BY MIKE STEPHENS (10/11)		2000 D/G I2C CPU BD
CHECKED		
APPROVED	UPDATE: 7/28/91	ECR: 2458 SHEET 2 OF 5

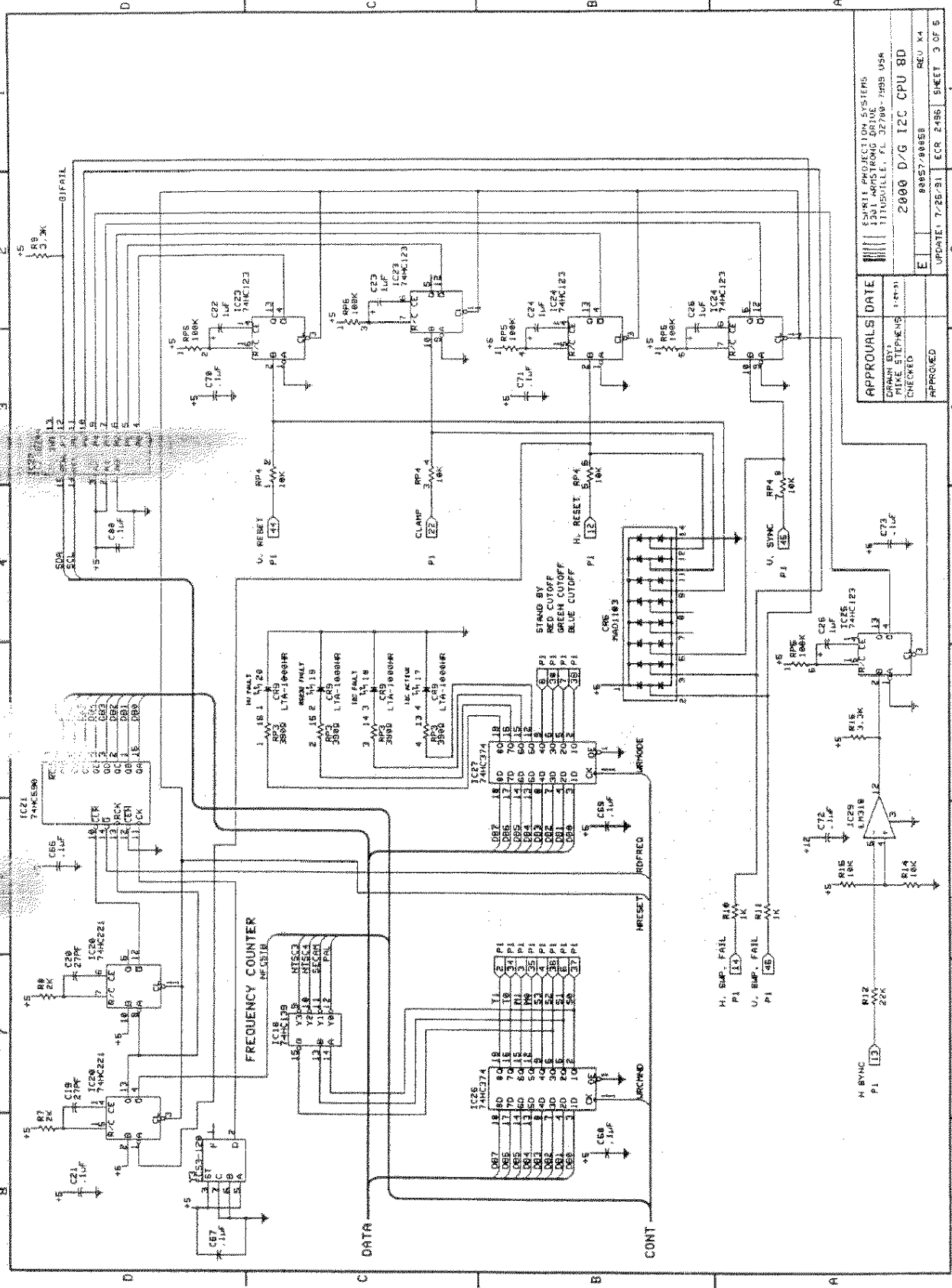

ESPRIT PROJECT/DA SYSTEMS 1301 ARMSTRONG DRIVE HUNTSVILLE, AL 35894-0001	2000 D/G I2C CPU 80
APPROVALS: DATE	REV: X4
DRAWN BY: MIKE STEPHENS	UPDATE: 7/25/91 ECR 2496 SHEET 3 OF 5
CHECKED:	APPROVED:

CPU MODULE (80587X4) SCHEMATIC 3 of 5

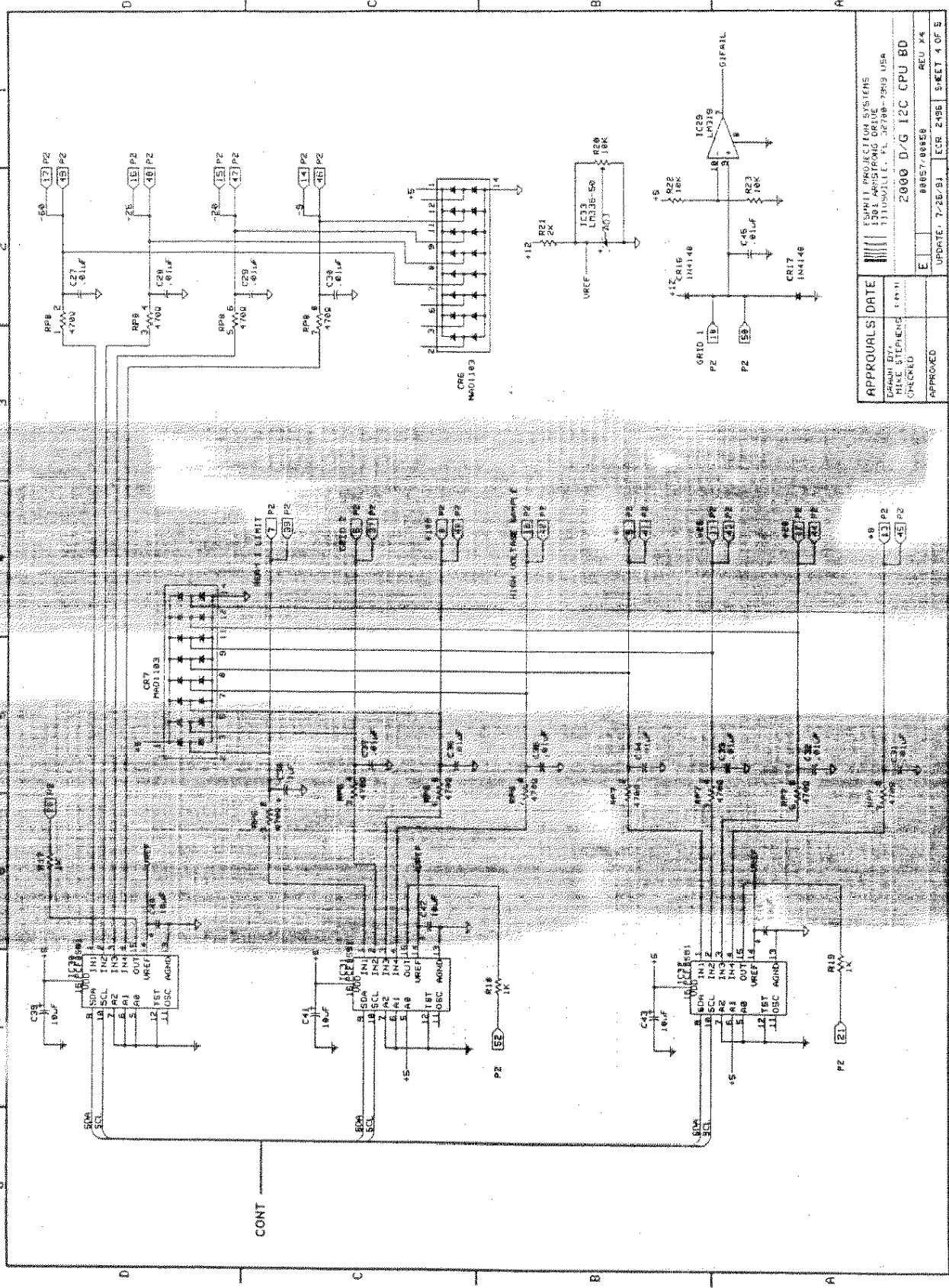

APPROVALS:	DATE:	ESPRIT PRODUCTION SYSTEMS 1301 AMSTRONG DRIVE LITTLEVILLE, PA 37788-7819 USA
DESIGNED BY:	DATE:	2000 D/G 12C CPU B0
CHECKED:	DATE:	88057/8858
APPROVED:	DATE:	REU X4
UPDATE: 7-25/91		ESR 2495
PAGE 2		SHEET 4 OF 5

CPU MODULE (80587X4) SCHEMATIC 4 of 5

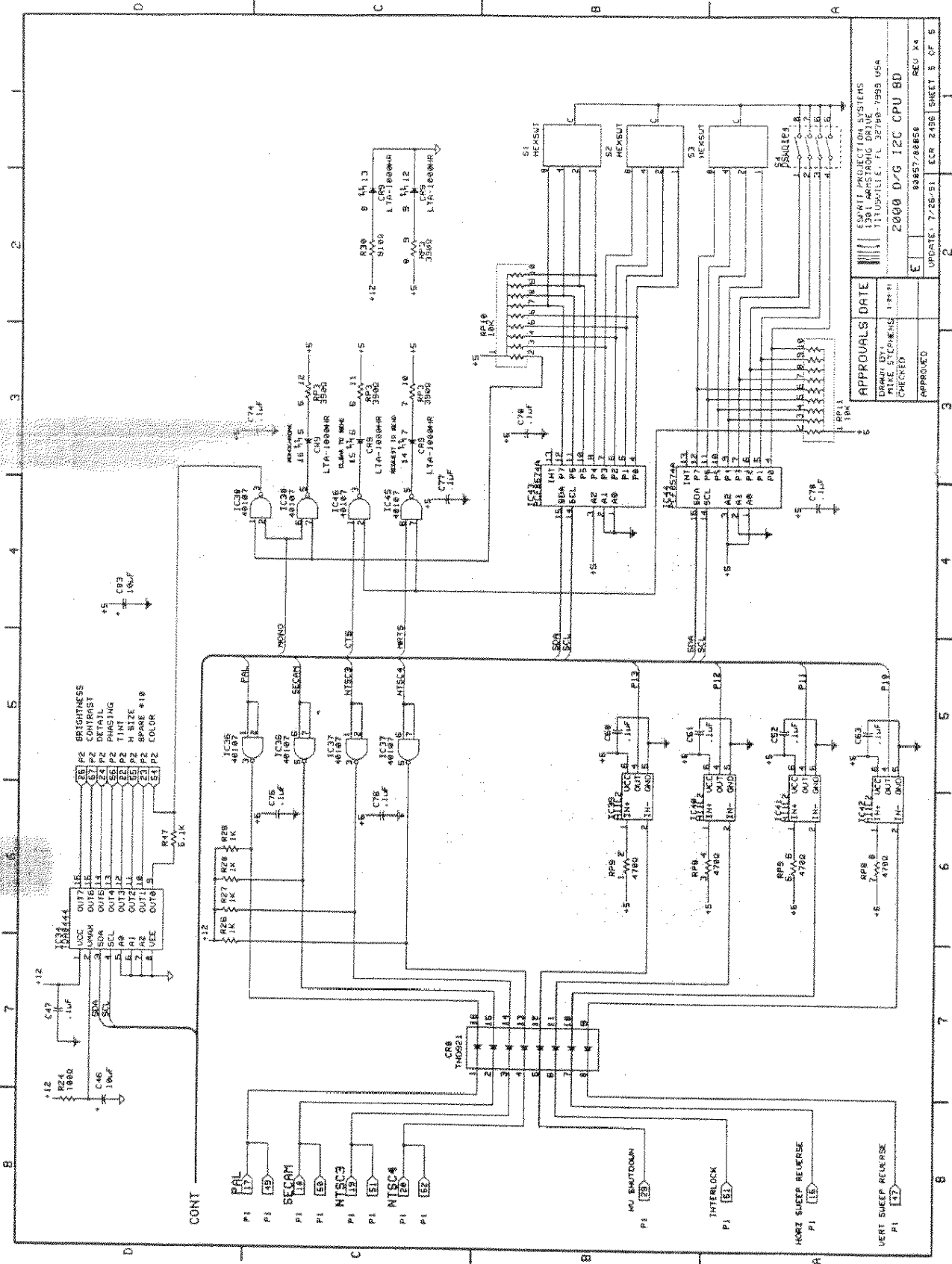

APPROVALS DATE		DATE	
DESIGNED BY	DATE	CHECKED	DATE
W. J. STICKENS	1-11-11		
APPROVED		DATE	
		1-11-11	

CPU MODULE (80587X4)
 ESTRIT PROJECTION SYSTEMS
 111100111.5 111100111.5 111100111.5 111100111.5
 2000 D/G T2C CPU 8D
 UPDATE: 7-26-51 ECR 2436 SHEET 5 OF 5
 80587/80858 REV X4

CPU MODULE (80587X4) SCHEMATIC 5 of 5

I²C ADDRESS REFERENCE GUIDE

ADDRESS	MODULE	DESIGNATOR #	DEVICE	DESCRIPTION
A0	CPU	IC7	PCF8583	RAM/CLOCK
70	CPU	IC19	PCF8557A	8-BIT I/O
7C	CPU	IC22	PCF8587A	8-BIT I/O
78	CPU	IC43	PCF8574A	8-BIT I/O
7A	CPU	IC44	PCF8574A	8-BIT I/O
90	CPU	IC30	PCF8591	A/D CONVERTER
92	CPU	IC31	PCF8591	A/D CONVERTER
8C	VERTICAL DEFL	IC4	TDA8432	VERTICAL DEFL
40	CPU	IC34	TDA8444	OCTAL DAC
42	CPU	IC35	TDA8444	OCTAL DAC
74-30,32,34,36	REGISTRATION	IC165	PCF8577A	LCD CONTROL
74-38,3A,3C,3E	REGISTRATION	IC165	TDA8577A	LCD CONTROL
4E	REGISTRATION	IC64	TDA8444	OCTAL DAC
4E	REGISTRATION	IC74	TDA8444	OCTAL DAC
4E	REGISTRATION	IC84	TDA8444	OCTAL DAC
4E	REGISTRATION	IC94	TDA8444	OCTAL DAC
4E	REGISTRATION	IC104	TDA8444	OCTAL DAC
4E	REGISTRATION	IC114	TDA8444	OCTAL DAC
4E	REGISTRATION	IC124	TDA8444	OCTAL DAC
4E	REGISTRATION	IC134	TDA8444	OCTAL DAC
4E	REGISTRATION	IC145	TDA8444	OCTAL DAC
4E	REGISTRATION	IC151	TDA8444	OCTAL DAC

I²C ERROR MESSAGES: (DID NOT ACKNOWLEDGE)

ERROR 20: SLAVE TO WRITE DATA ADDRESS

ERROR 30: TRANSMITTED DATA TO SLAVE DEVICE

ERROR 40: SLAVE TO READ DATA ADDRESS

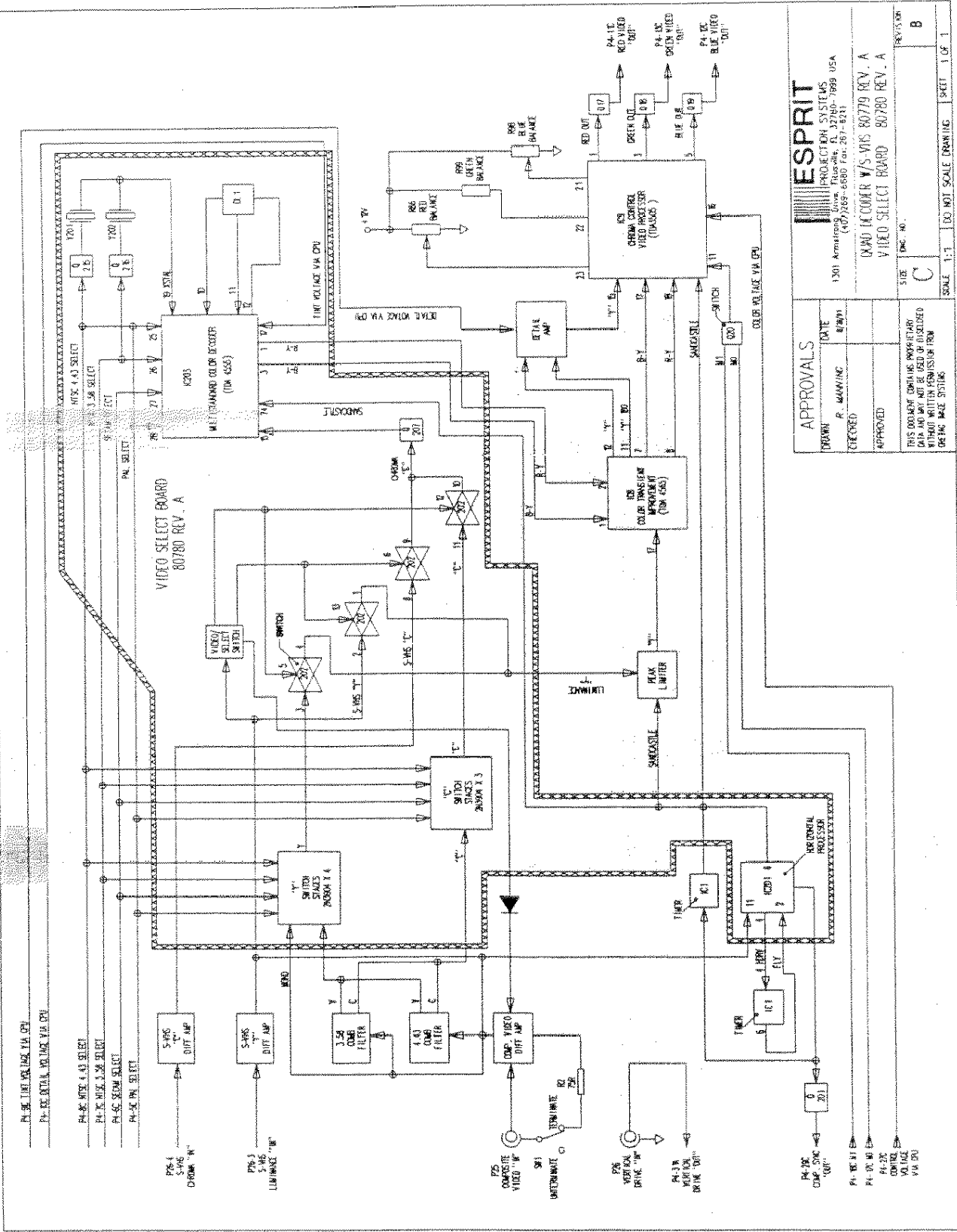

APPROVALS		ESPRIT PRODUCTION SYSTEMS 1301 Armstrong Drive, Ft. Worth, TX 76104-7889 USA (817) 289-6800 Fax: 281-671	DRAWING NO. 80779 REV. A VIDEO SELECT BOARD 80780 REV. A	SIZE: DSC. NO. B SCALE: 1:1 (DO NOT SCALE DRAWING) SKETCH 1 OF 1
DESIGNED	DATE			
APPROVED	BY			

QUAD VIDEO DECODER (80779B) BLOCK DIAGRAM

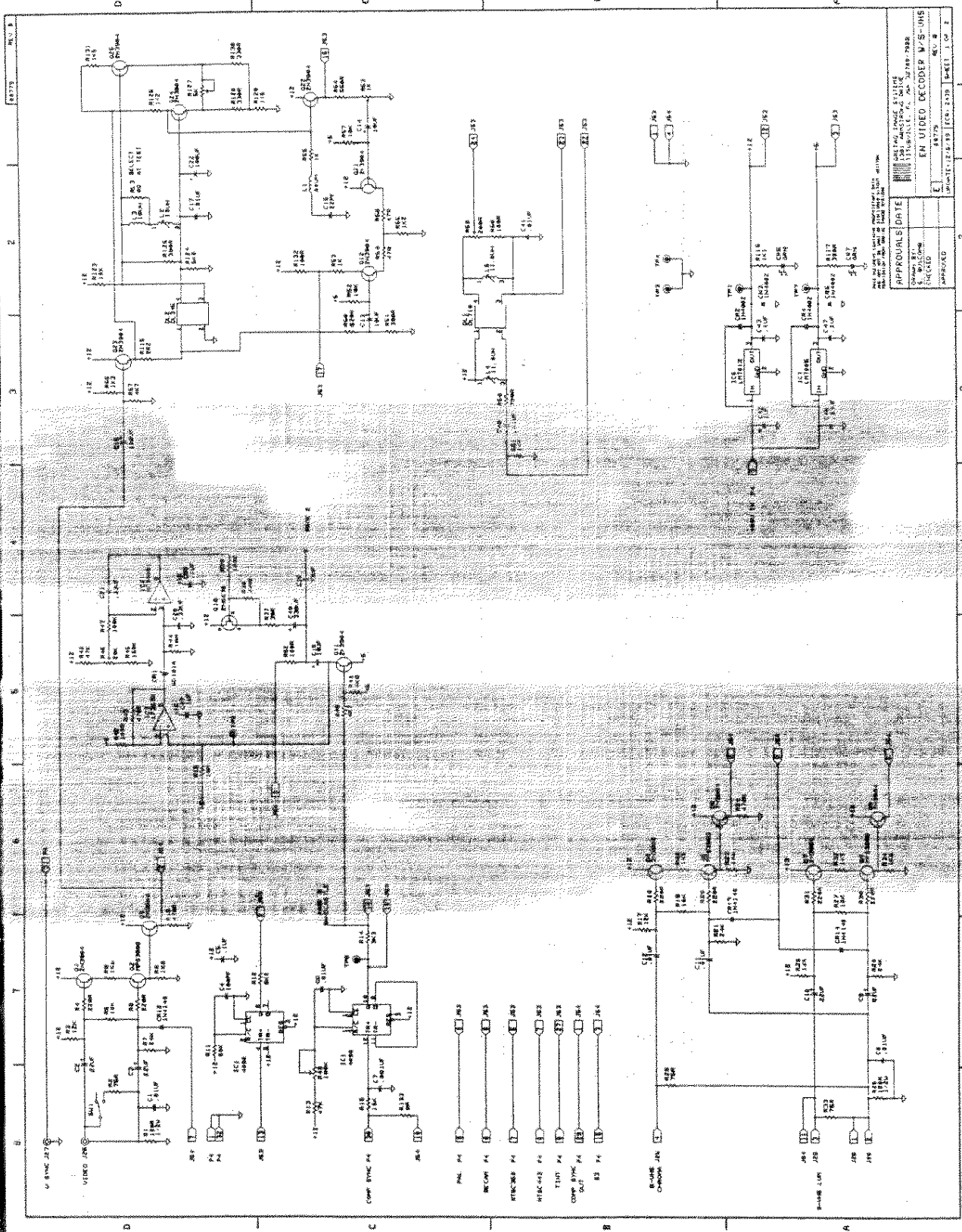

QUAD VIDEO DECODER (80779B) SCHEMATIC 1 of 2

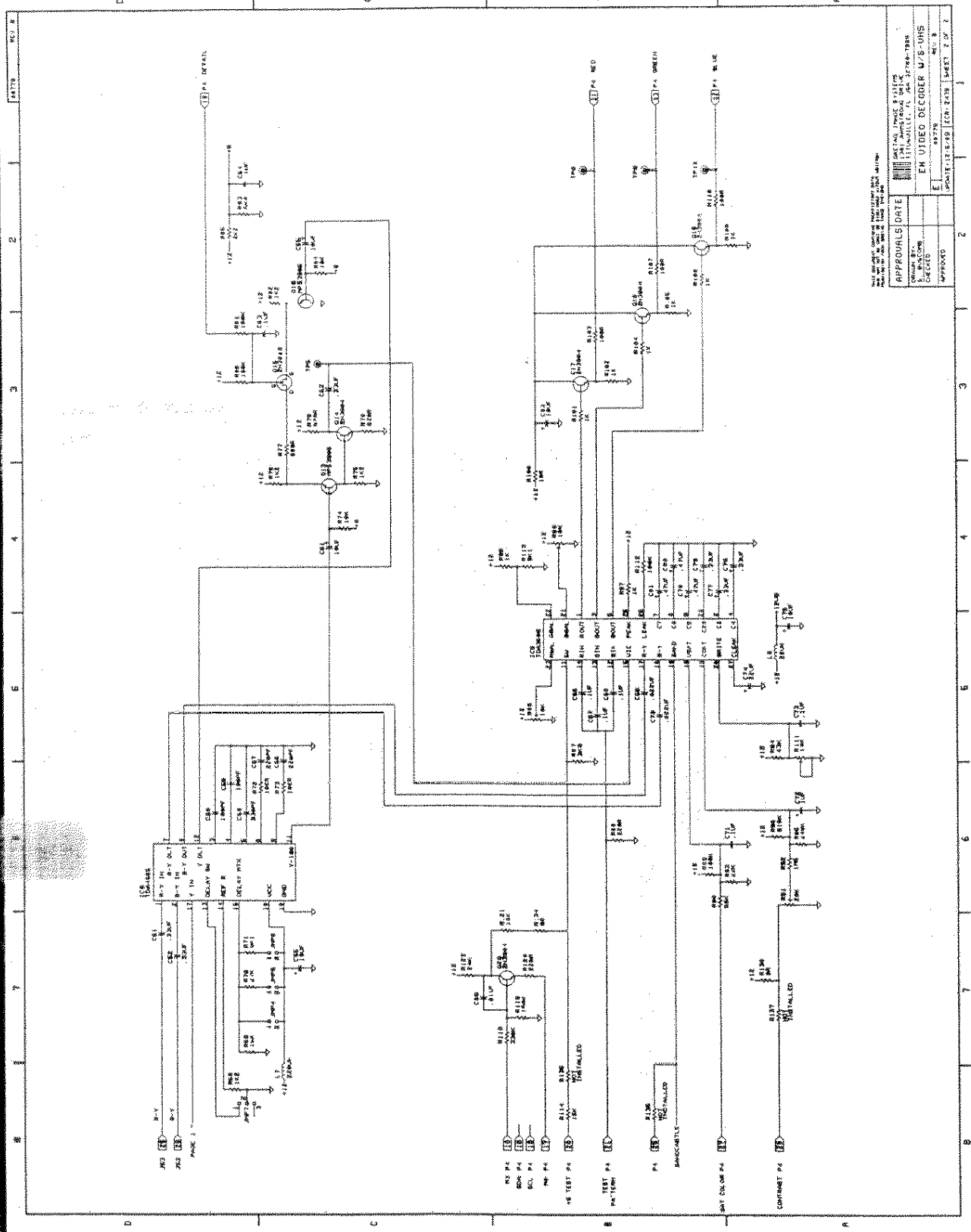

APPROVALS DATE		DESIGNED BY	DATE
APPROVED		DESIGNED BY	DATE
CREATED		DESIGNED BY	DATE
EN VIDEO DECODER U/S UNS		DESIGNED BY	DATE
REV. 9		DESIGNED BY	DATE
SHEET 2 OF 2		DESIGNED BY	DATE

QUAD VIDEO DECODER (80779B) SCHEMATIC 2 of 2

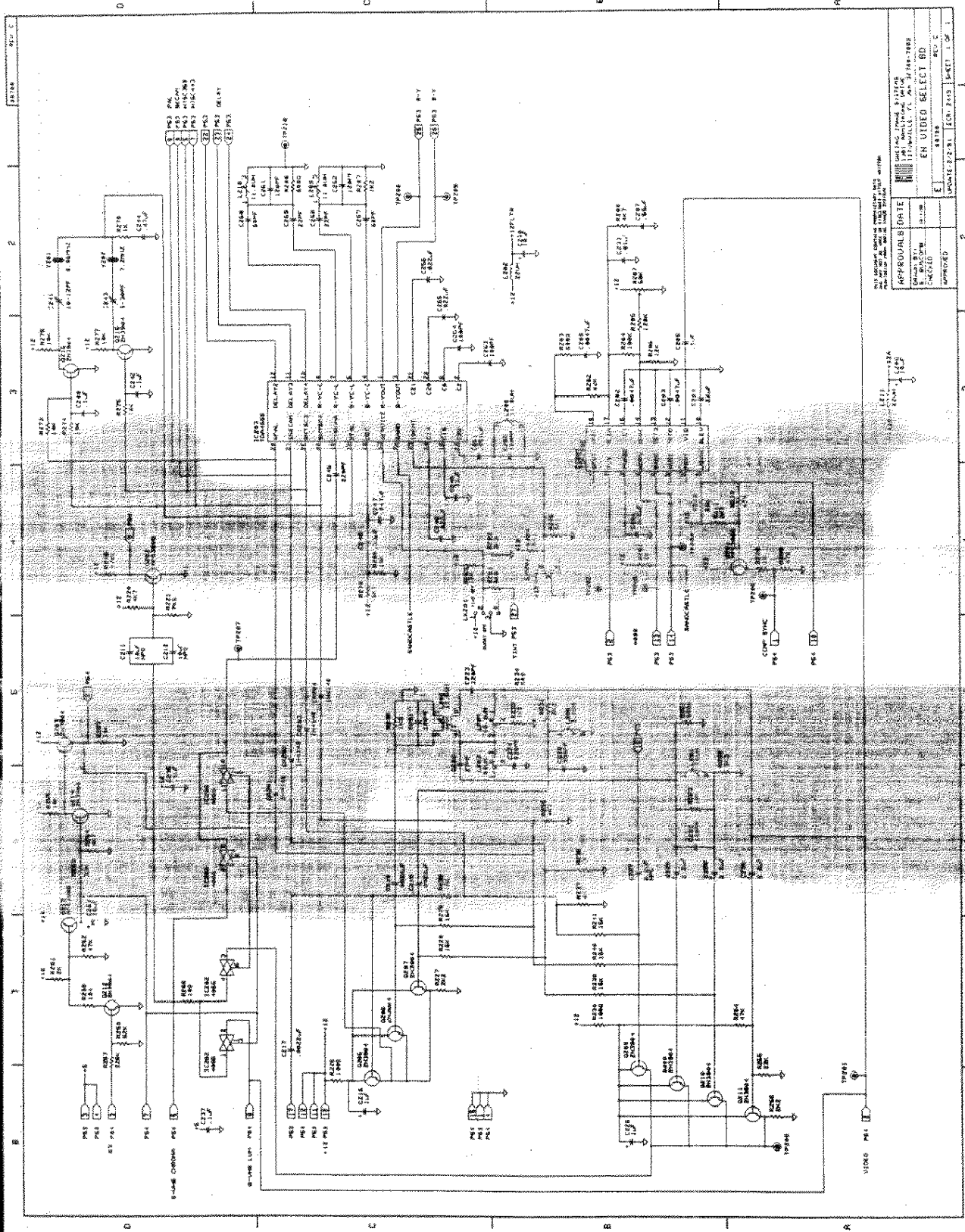

APPROVALS		DATE
DESIGNED BY	DATE	
CHECKED		
APPROVED		
EN VIDEO SELECT BD		
REV. 1	REV. 2	REV. 3
REV. 4	REV. 5	REV. 6

VIDEO SELECT BOARD (80780C) SCHEMATIC 1 of 1

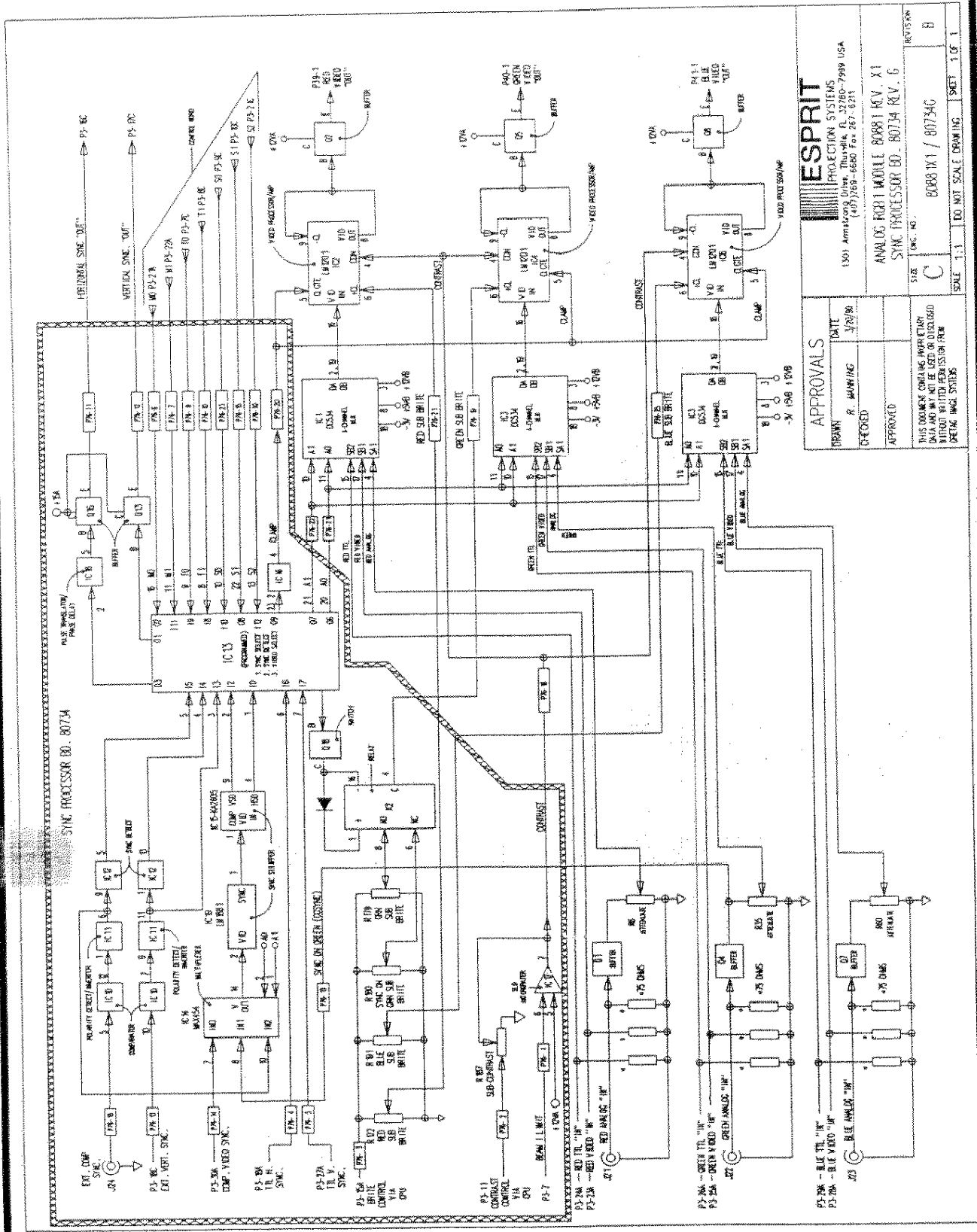

ANALOG RGB1 (80881X1) BLOCK DIAGRAM

ESPRIT PRODUCTION SYSTEMS 1501 Armstrong Drive - 800 Park Ave. - 80734 (410) 328-8800	
DATE 3/78/90	REVISION B
DESIGNED R. BAWRING	SCALE 1:1
APPROVED	SHEET 1 OF 1
THIS DOCUMENT CONTAINS PROPRIETARY DATA AND MAY NOT BE USED OR DISCLOSED WITHOUT WRITTEN PERMISSION FROM DETAILED SIGNAL SOURCES	
MODEL NO. 80881X1 / 80734C	DO NOT SCALE DRAWING

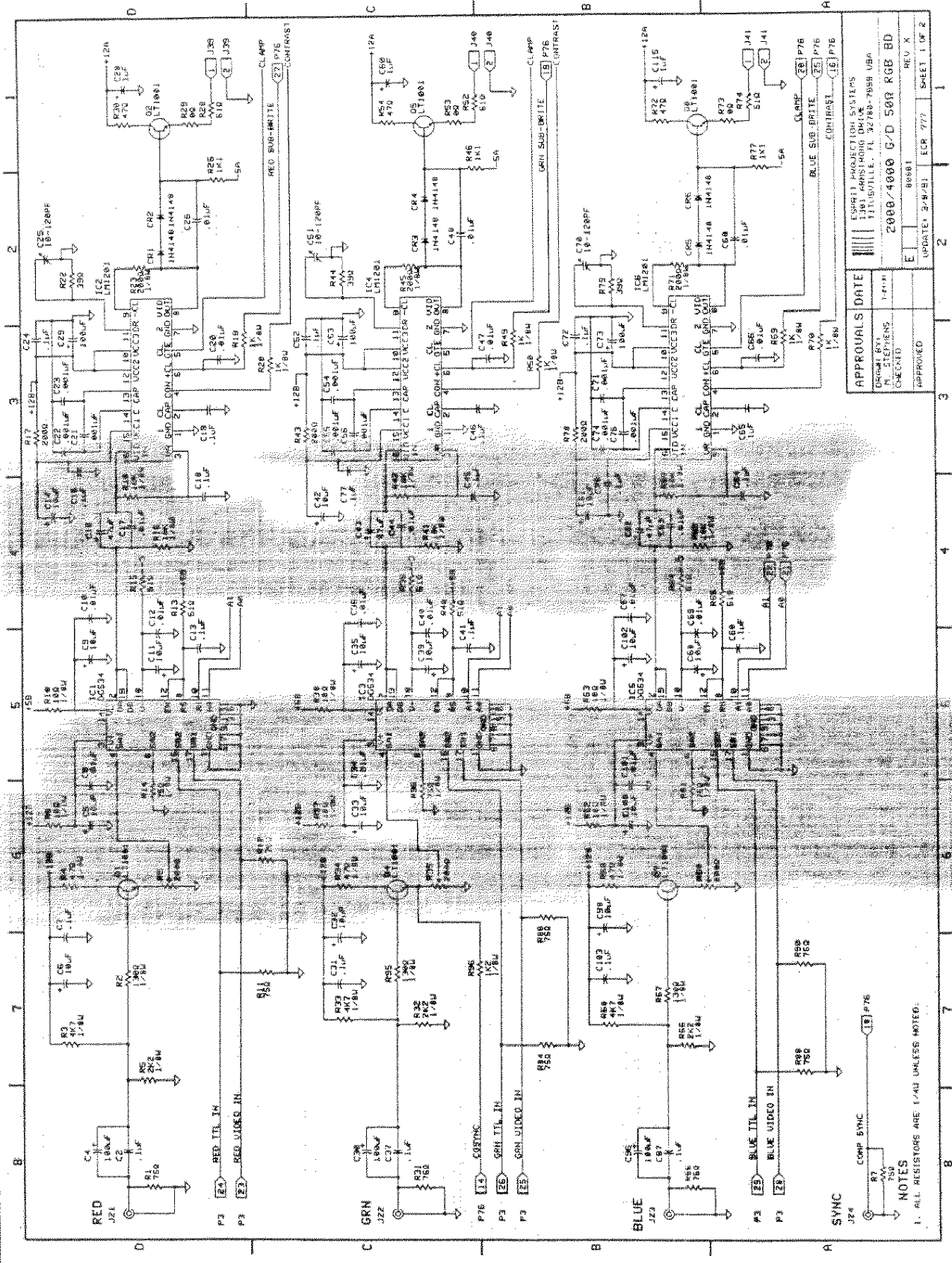

APPROVALS		DATE
DESIGNED BY	M. STEPHENS	12-7-77
CHECKED		
APPROVED		

ESPRIT MONITORING SYSTEMS 1381 HARRISON DRIVE HILLSVILLE, FL 32789-7959 USA	
2000/4000 G/D 500 RGB BD	
REV. X	SHEET 1 OF 2
80881	ECR 777
3-9-81	

ANALOG RGB1 (80881X1) SCHEMATIC 1 of 2

1. ALL RESISTORS ARE 1/4W UNLESS NOTED.

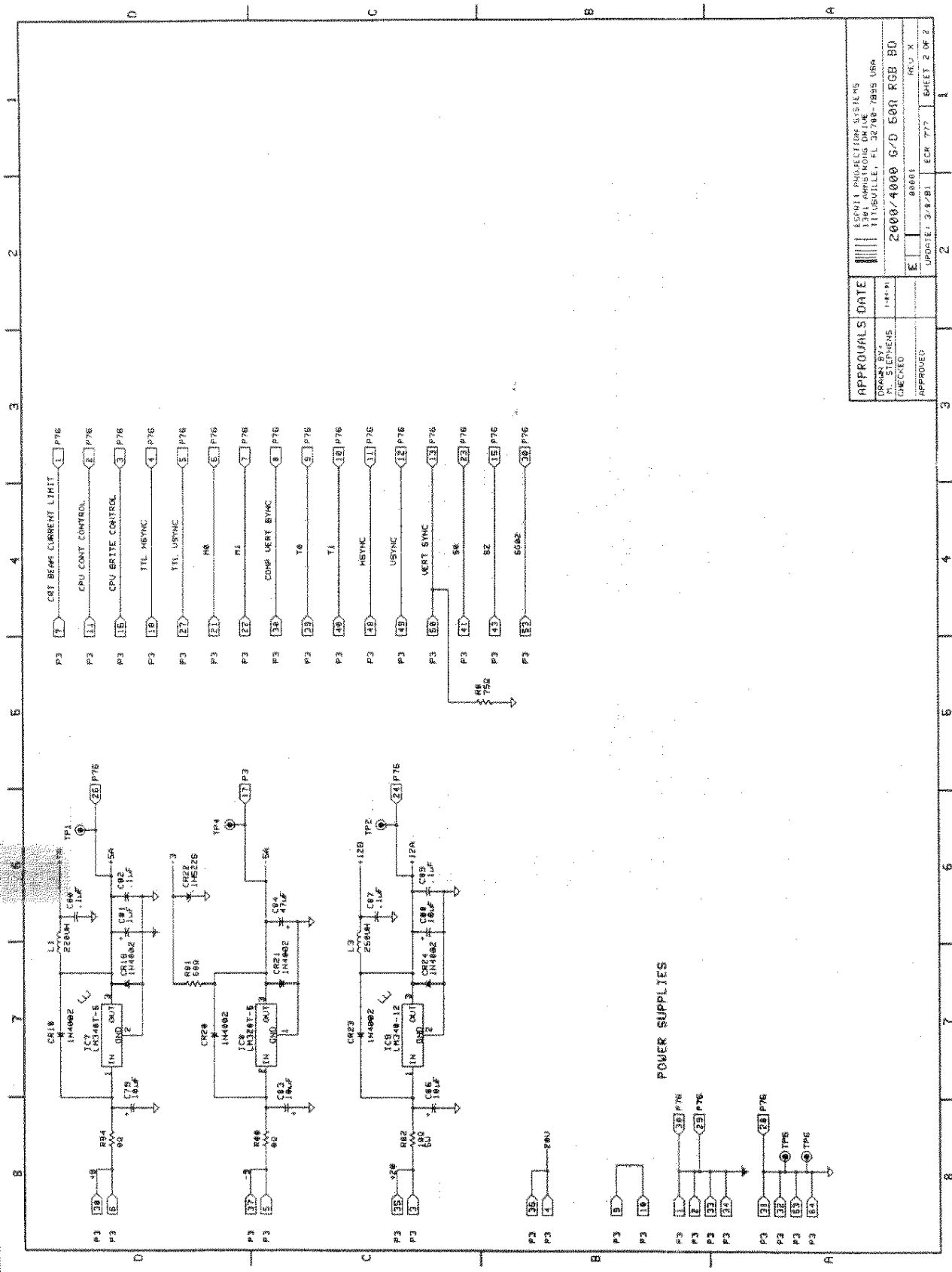

APPROVALS	DATE	DESCRIPTION
DESIGNED BY M. STEPHENS	1-8-88	ESPRIT PROJECTION SYSTEMS 1301 ARMSTRONG DRIVE TITUSVILLE, FL 32780-7895 USA
CHECKED		2000/4000 G/D 500 RGB BD
APPROVED		00001
		UPDATE: 3/4/91 ECR 717
		REV. X
		SHEET 2 OF 2

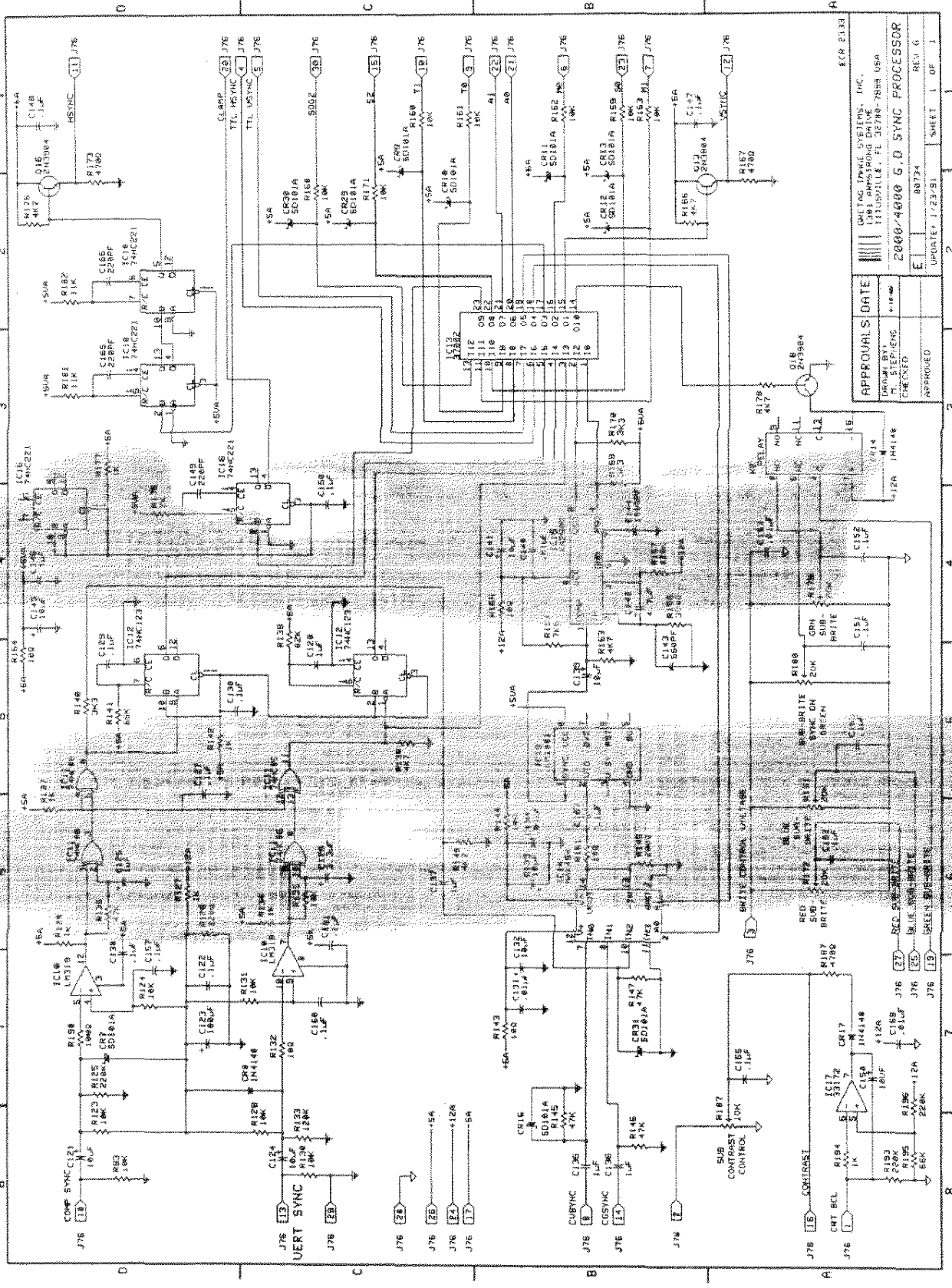

SYNC PROCESSOR (80734G) SCHEMATIC 1011

APPROVALS/DATE		DRAWN BY		CHECKED		APPROVED	
		M. STEPHENS					
DATE		1/23/91		SHEET 1 OF 1		REV G	
E		80734		UPDATE		2000/4000 6.0 SYNC PROCESSOR	
						QETAG IMAGE SYSTEMS, INC. 1303 AMHSBROOK DRIVE, HUNTSVILLE, AL 35894-7858 USA	

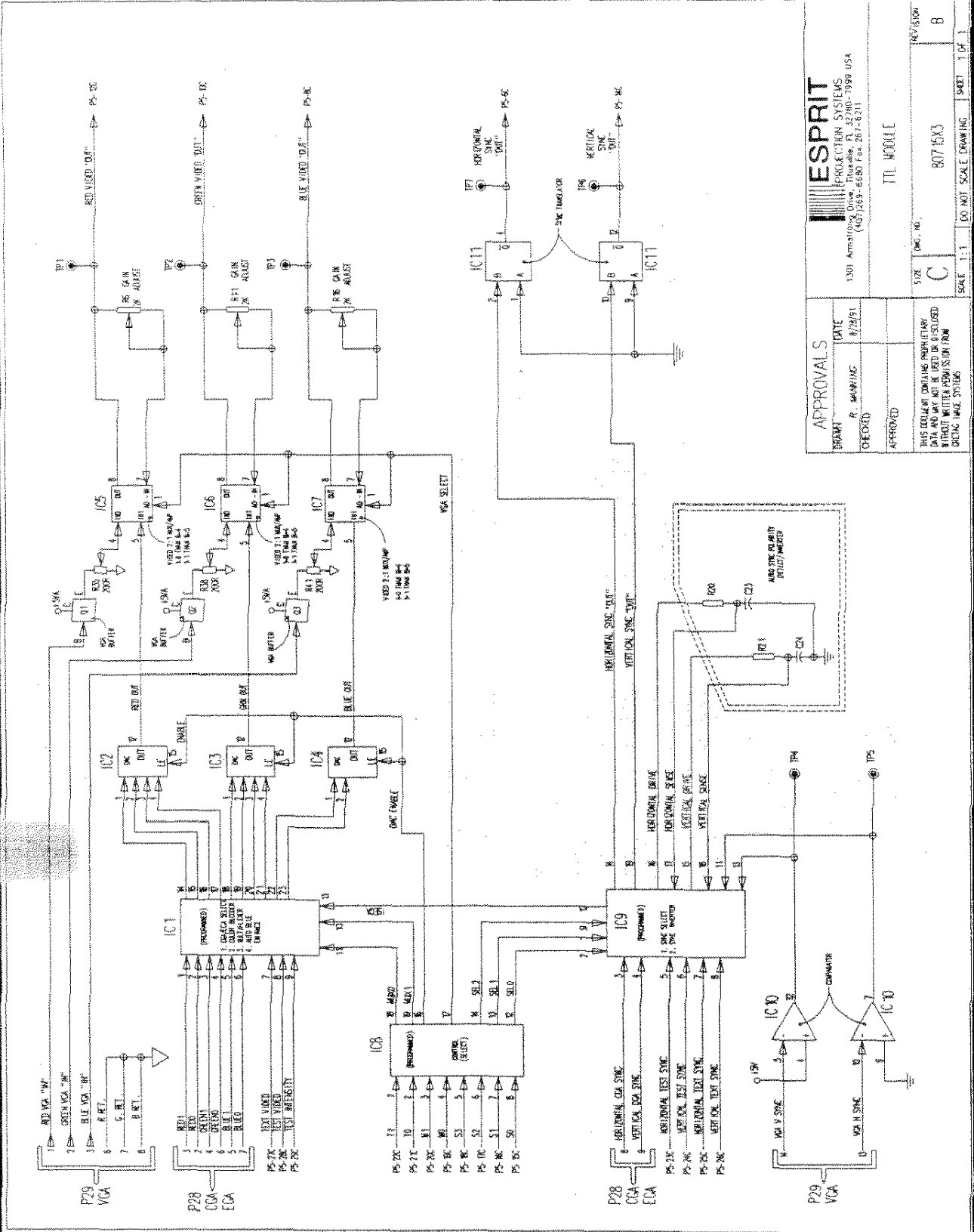

		ESPRIT PROJECTION SYSTEMS 1301 Armstrong Drive Blue Bell, PA 19008-1999 USA (610) 263-8888 Fax: 263-8233	
APPROVALS DRAWN: R. MAWHAIG CHECKED: [] APPROVED: []		DATE: 8/28/81	TITLE: TTL MODULE
THIS DOCUMENT CONTAINS PROPRIETARY DATA AND MAY NOT BE REPRODUCED OR DISCLOSED WITHOUT WRITTEN PERMISSION FROM ESPRIT PROJECTION SYSTEMS		SIZE: 060, 16, C	REV: 010 B
SCALE: 1:1 DO NOT SCALE DRAWING		SHEET: 1 OF 1	

TTL MODULE (80715X3) BLOCK DIAGRAM

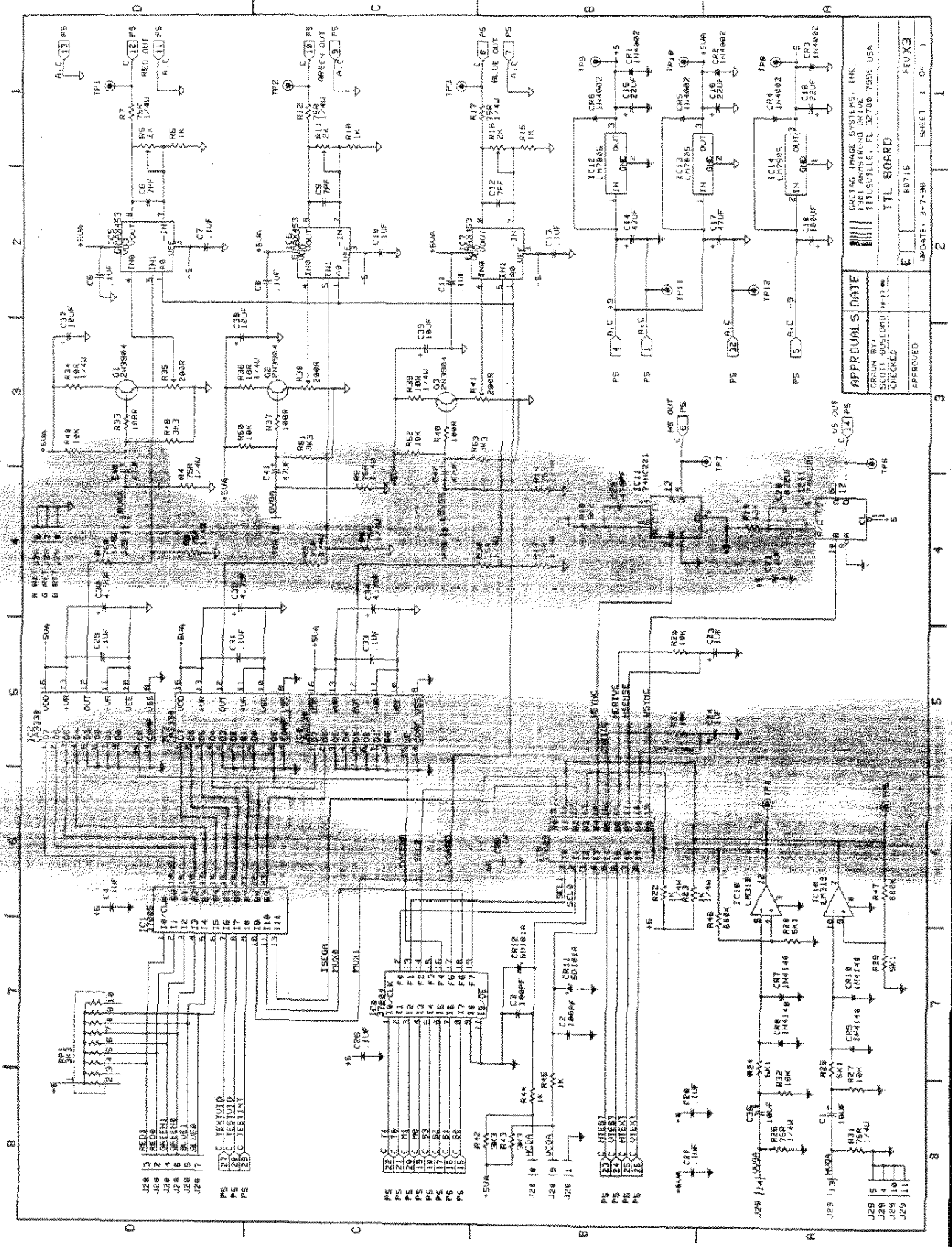

APPROVALS DATE
 DRAWN BY: SCOTT BUSCH
 CHECKED: []
 APPROVED: []

TTL BOARD
 PART NO: 80715
 REVISED: 3-7-96
 SHEET 1 OF 1

REV X3

INDUSTRY MAGAZINE SYSTEMS, INC.
 1381 ARMSTRONG BLVD
 TITUSVILLE, FL 32780-7555 USA

TTL MODULE (80715X3) SCHEMATIC 1 of 1

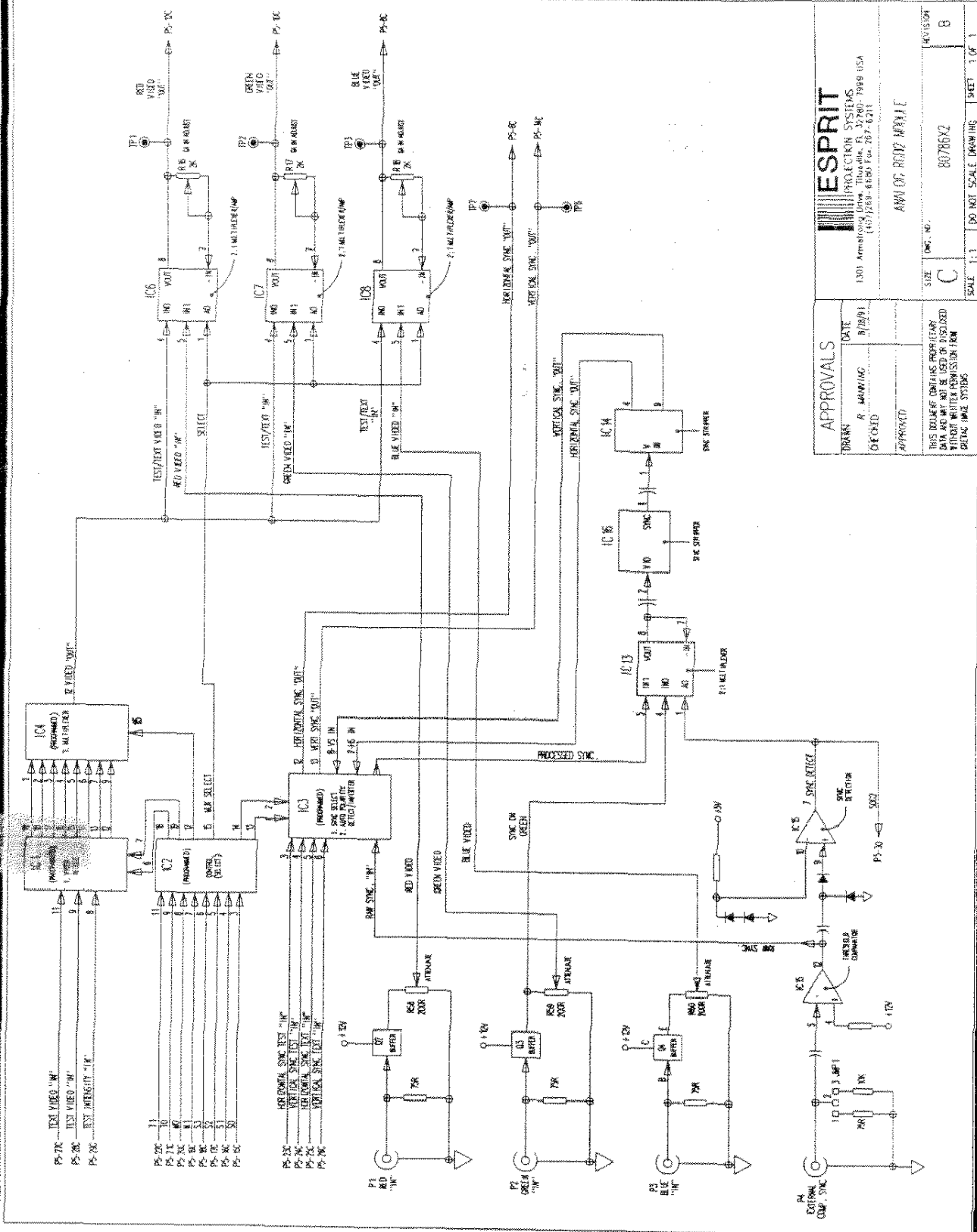

		ESPRIT ELECTRONIC SYSTEMS 1300 Arroyo Avenue, El Segundo, CA 90245-1999 USA (415) 258-6180 Fax: 258-6210	
APPROVALS DRAWN: R. MANNING CHECKED: [] APPROVED: []		DATE: 8/28/91	
THIS DRAWING CONTAINS PROPRIETARY DATA AND MAY NOT BE REPRODUCED OR TRANSMITTED IN ANY FORM OR BY ANY MEANS WITHOUT WRITTEN PERMISSION FROM ESPRIT ELECTRONIC SYSTEMS.		ANALOG RGB2 MODULE	
SIZE: C	DWG. NO.: 80786X2	DIVISION: B	SHEET: 1 OF 1
SCALE: 1:1 DO NOT SCALE DRAWING			

ANALOG RGB2 MODULE (80786X2) BLOCK DIAGRAM

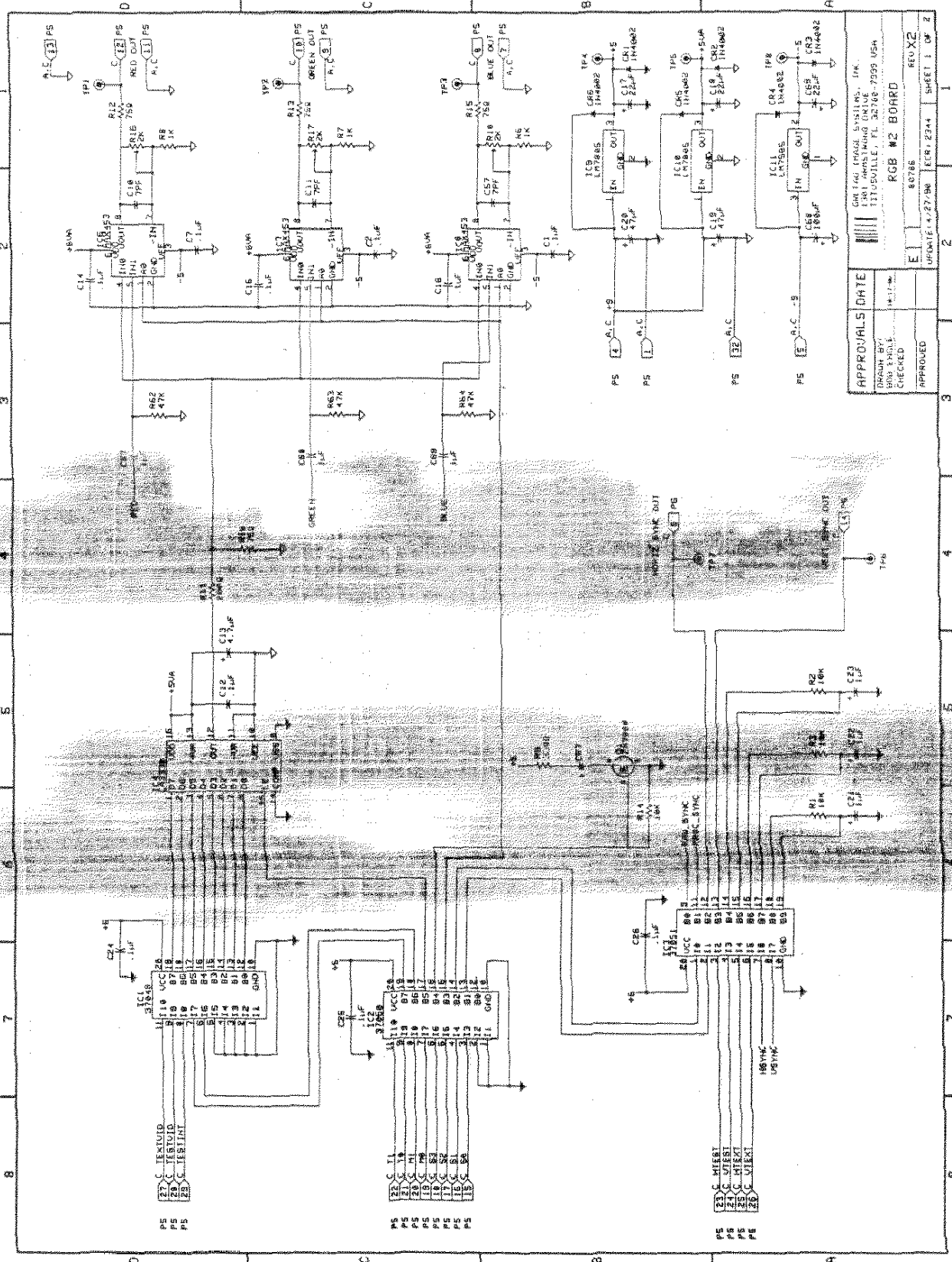

APPROVALS	DATE
DRAWN BY: [Signature]	10/1/80
CHECKED	
APPROVED	

GRIFFIN IMAGE SYSTEMS, INC.
 1315 WINDMILL DRIVE, #2009 USA
 TUSTALVILLE, FL 32780

RGB #2 BOARD
 80786

UPDATE: **27-NB	ECR: 2344	SHEET 1 OF 2
-----------------	-----------	--------------

ANALOG RGB2 MODULE (80786X2) SCHEMATIC 1 of 2

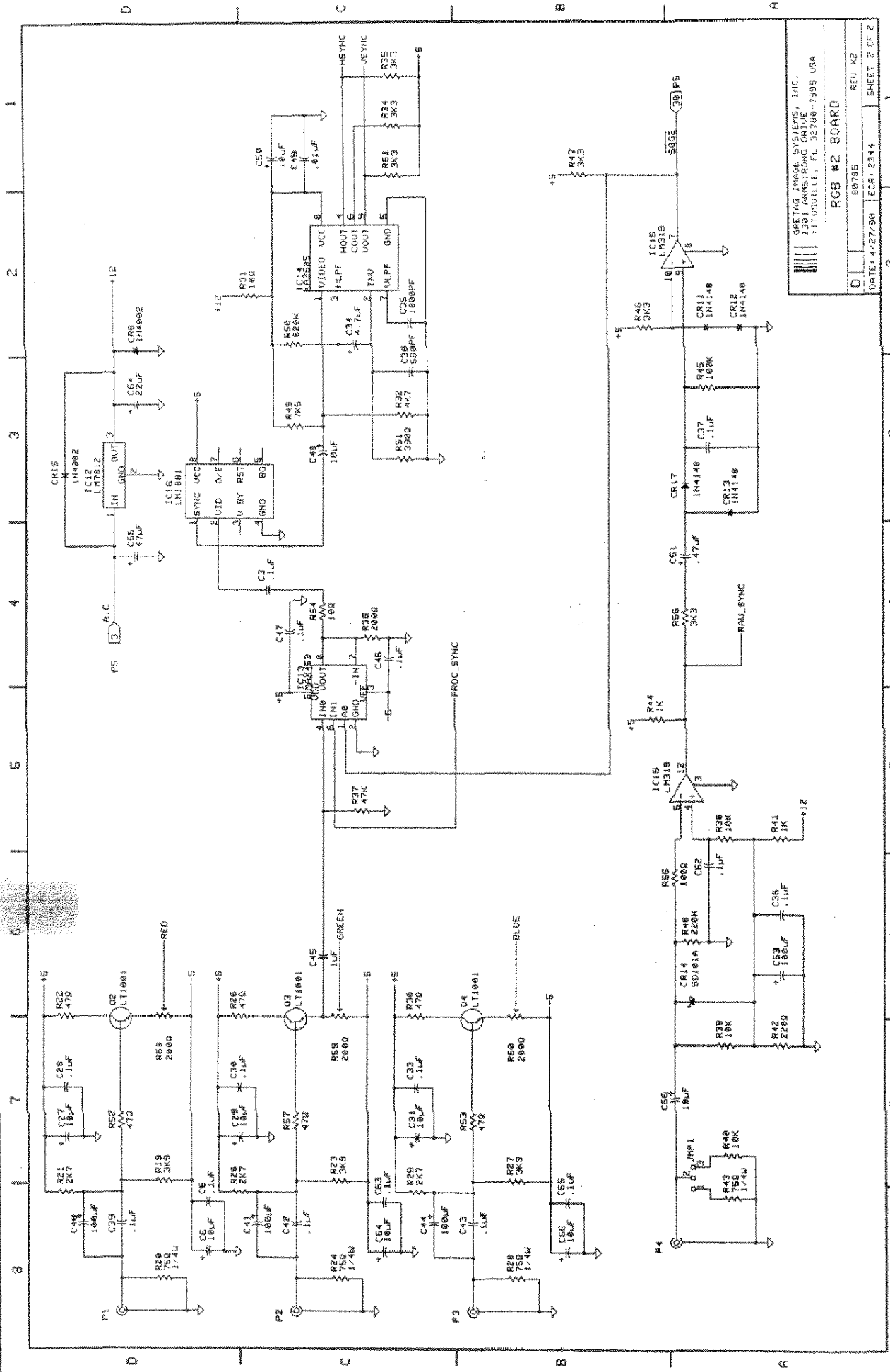

ANALOG RGB2 MODULE (80786X2) SCHEMATIC 2 of 2

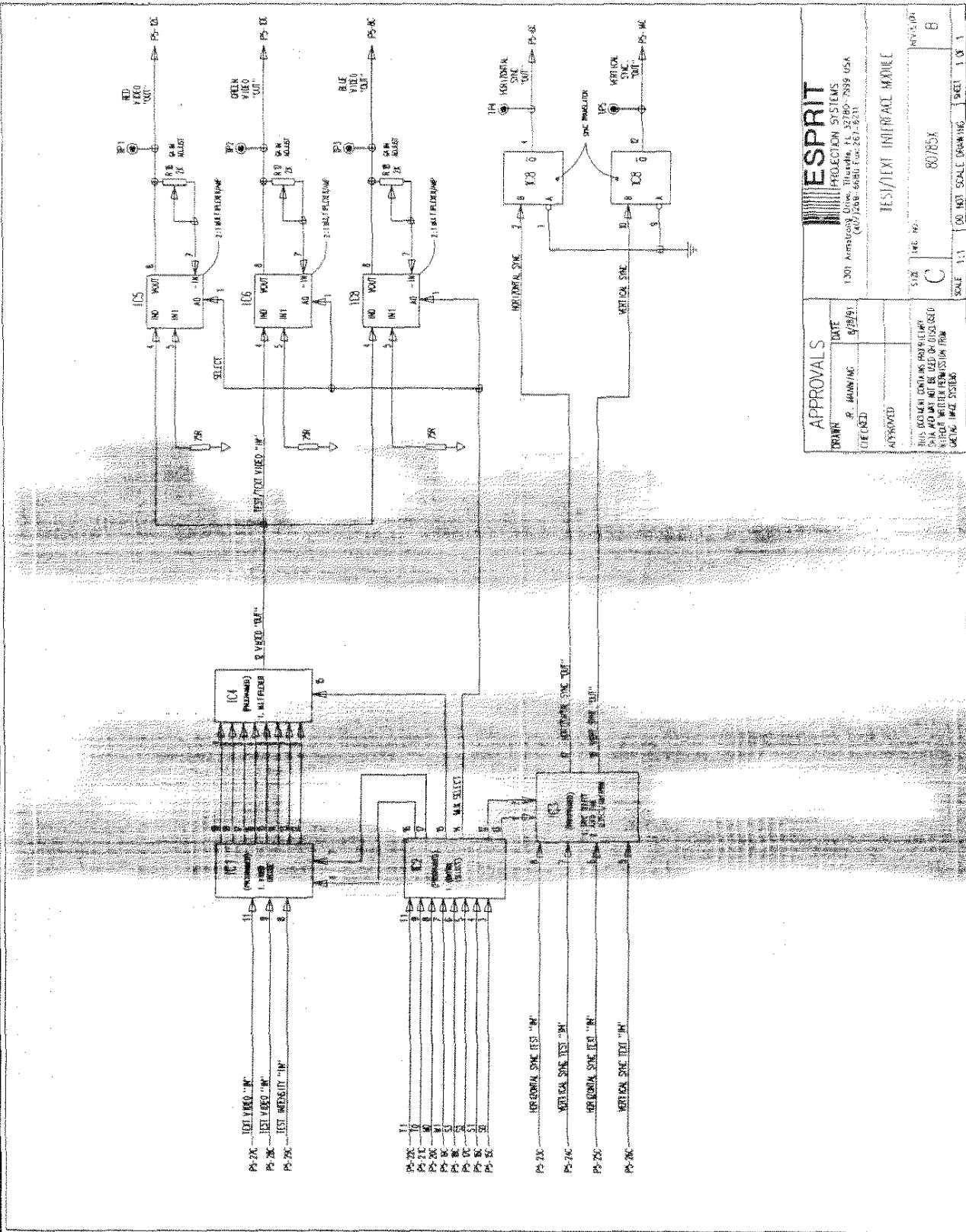

ESPRIT PROJECTION SYSTEMS 1201 Armstrong Drive, Tallahassee, FL 32306-2889 USA (407)268-6801 Fax: 267-8231		TEST/TEXT INTERFACE MODULE SIZE: 140.00 80785X 80785X	
APPROVALS DRAWN: P. HANNING CHECKED: [] APPROVED: []		DATE: 8/28/91 THIS DOCUMENT CONTAINS PROPRIETARY DATA AND MAY NOT BE USED OR DISCLOSED WITHOUT WRITTEN PERMISSION FROM ESPRIT IMAGE SYSTEMS	
SCALE: 1:1 100.00% SCALE DRAWING		SHEET: 1 OF 1 80785X	

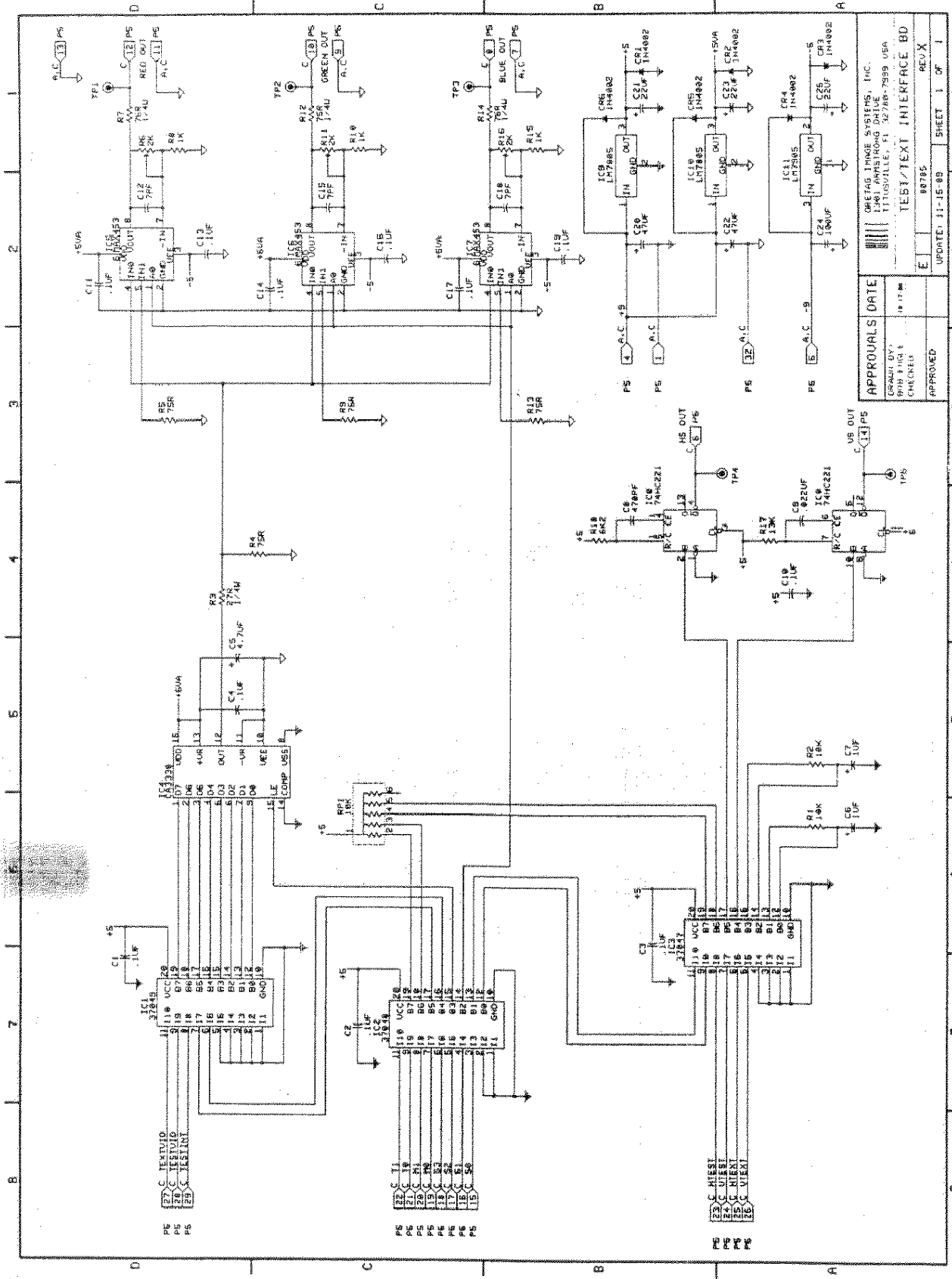

APPROVALS DATE	OPERATED BY	DATE
APPROVED	CHANGED	18 12 88
REPORTED 11-15-88	88785	REU X
SHEET 1 OF 1		

OMETAG IMAGE SYSTEMS, INC.
 1180 ANNSTRONG DRIVE
 VITTIUSVILLE, IL 32748-7999 USA

TEST/TEXT INTERFACE BD

TEST/TEXT INTERFACE MODULE (80785X) SCHEMATIC 1 of 1

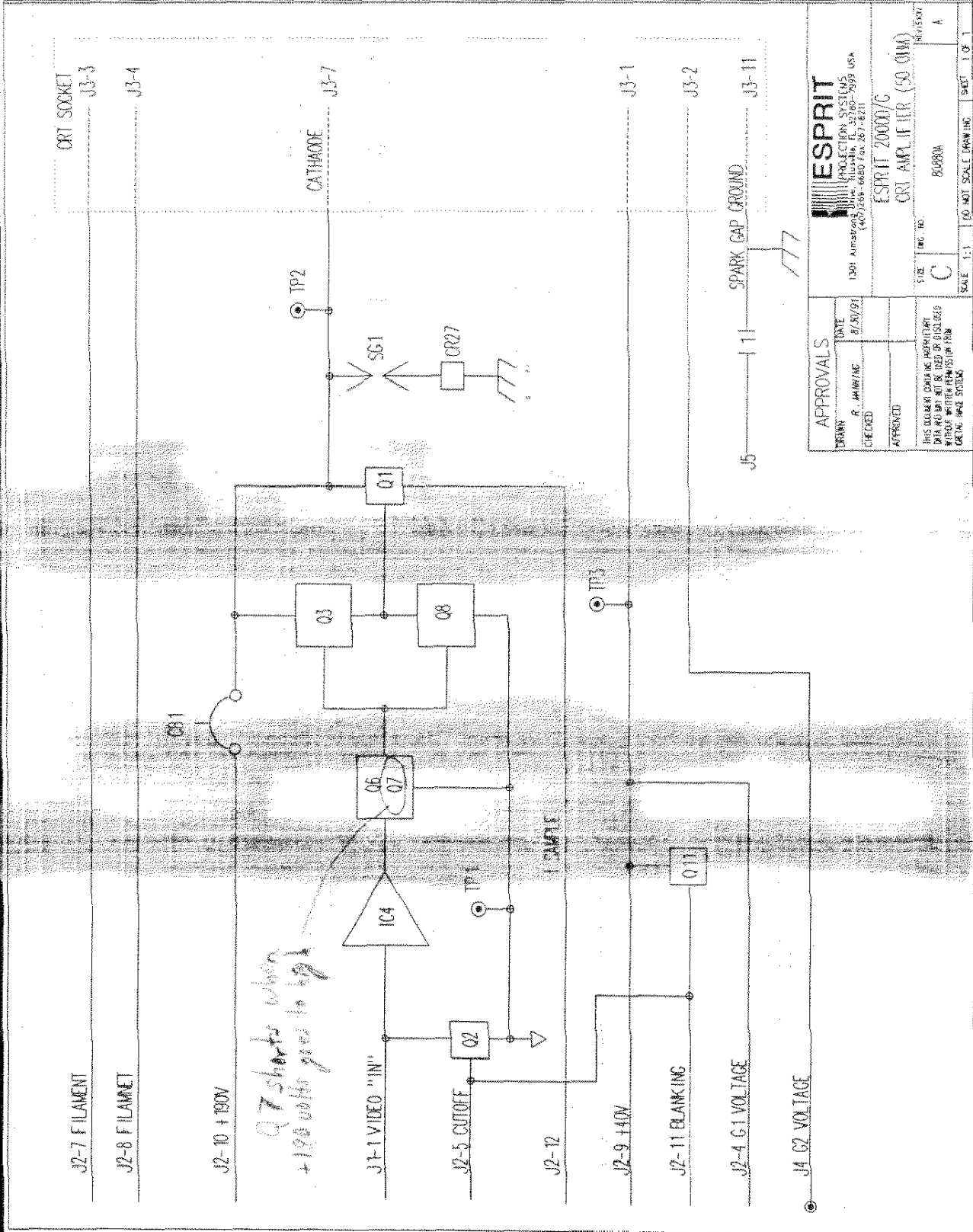

APPROVALS		DATE	
DESIGNED	R. HAWKING	8/25/91	
CHECKED			
APPROVED			

THIS DOCUMENT CONTAINS PROPRIETARY DATA AND IS NOT TO BE REPRODUCED WITHOUT WRITTEN PERMISSION FROM METAL WORKS SYSTEMS

ESPRIT PRODUCTION SYSTEMS 1300 Alismont Dr. Tulsa, OK 74105-7999 USA (405)268-6680 Fax: 267-8711	ESPRIT 2000D/G CRT AMPLIFIER (50 OHM)	REV. NO. 80880B	REV. DATE A
---	--	--------------------	----------------

SIZE: C
SCALE: 1:1
SHEET: 1 OF 1

CRT AMPLIFIER CARD (80880B) BLOCK DIAGRAM

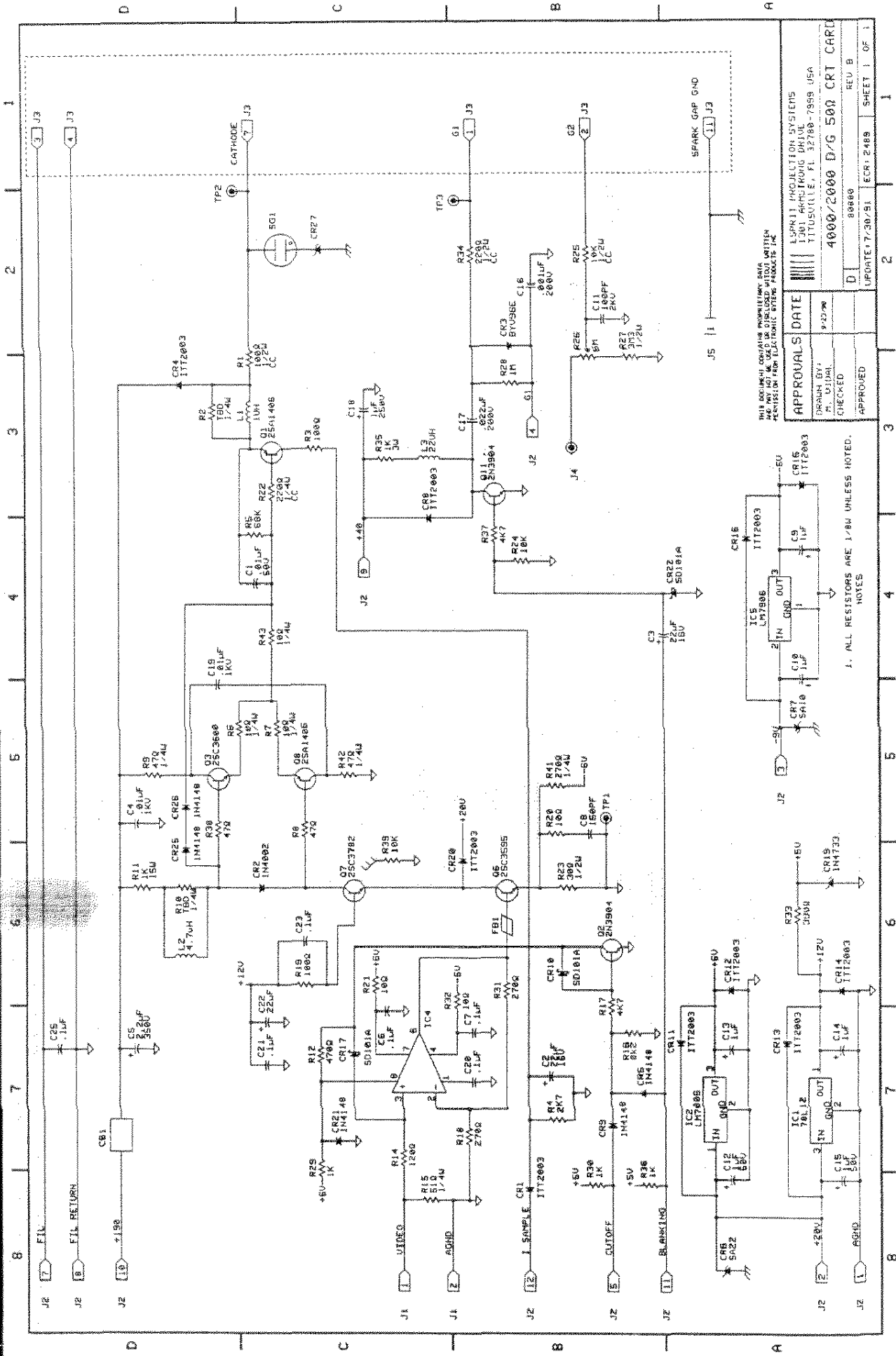

ALL RIGHTS RESERVED. NO PARTS OR MATERIALS TO BE REPRODUCED OR TRANSMITTED IN ANY FORM OR BY ANY MEANS, ELECTRONIC OR MECHANICAL, INCLUDING PHOTOCOPYING, RECORDING, OR BY ANY INFORMATION STORAGE AND RETRIEVAL SYSTEM.

APPROVALS DATE

DRAWN BY: A. D'JHAI
 CHECKED: 9-27-90
 APPROVED: 98869

DATE: 9-27-90

ESPRIT 2000 D/G 500 CRT CARD

REV. B

UPDATE: 7-30/91 ECR1 2489 SHEET 1 OF 1

1. ALL RESISTORS ARE 1/8W UNLESS NOTED.
 NOTES

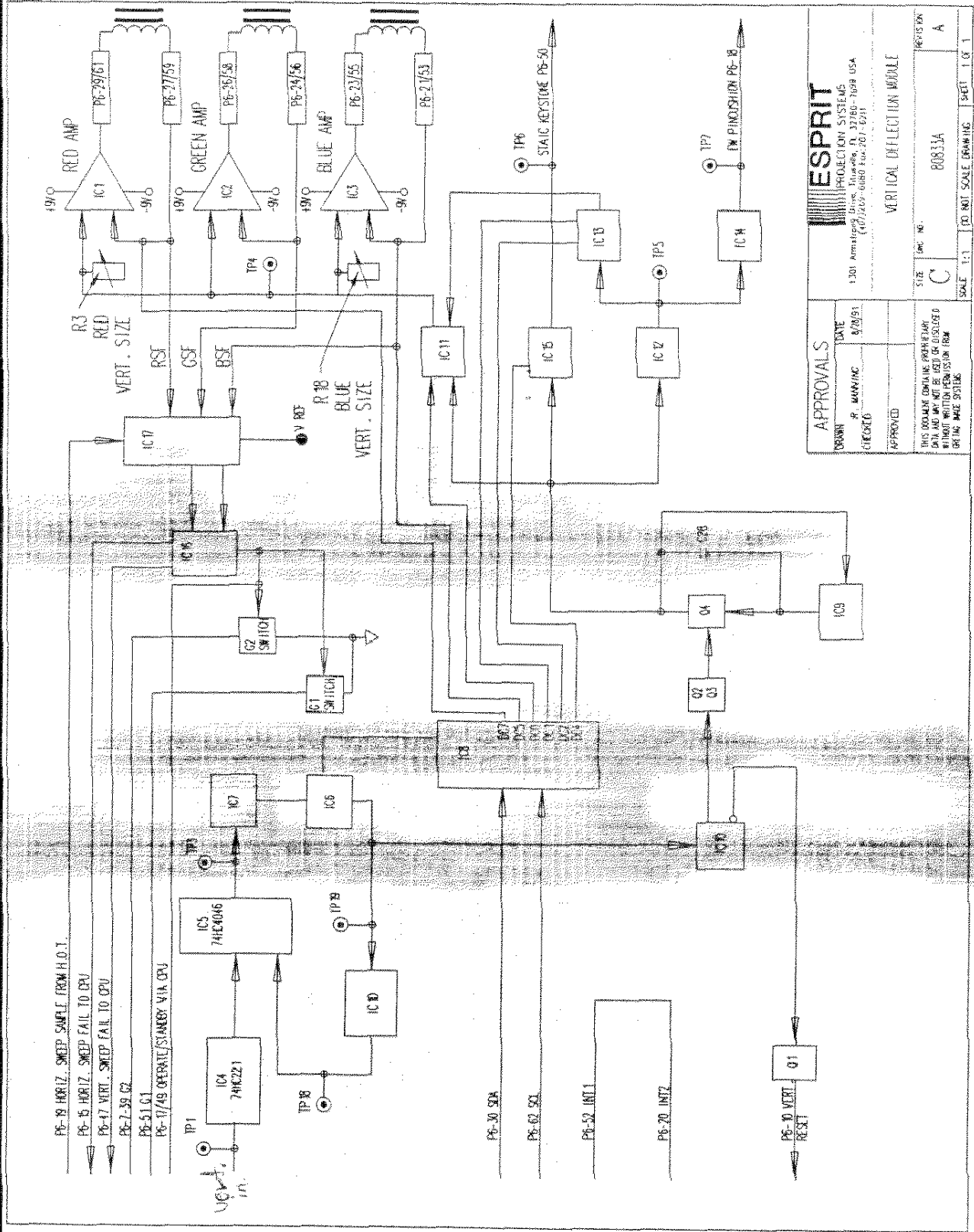

		PROJECTION SYSTEMS 1201 Armadillo Drive, Tulsa, OK 74116-1099 USA (405) 243-0880 Fax: (405) 243-0211	
APPROVALS DRAWN: R. MANNING CHECKED: [] APPROVED: []		DATE: 9/29/91	
THIS DOCUMENT CONTAINS PROPRIETARY DATA AND MAY NOT BE USED OR DISCLOSED WITHOUT THE WRITTEN PERMISSION OF PROJECTION SYSTEMS		TITLE: 80833A SCALE: 1:1 (DO NOT SCALE DRAWING)	
SHEET: 1 OF 1		DRAWING: 80833A	

VERTICAL DEFLECTION MODULE (80833A) BLOCK DIAGRAM

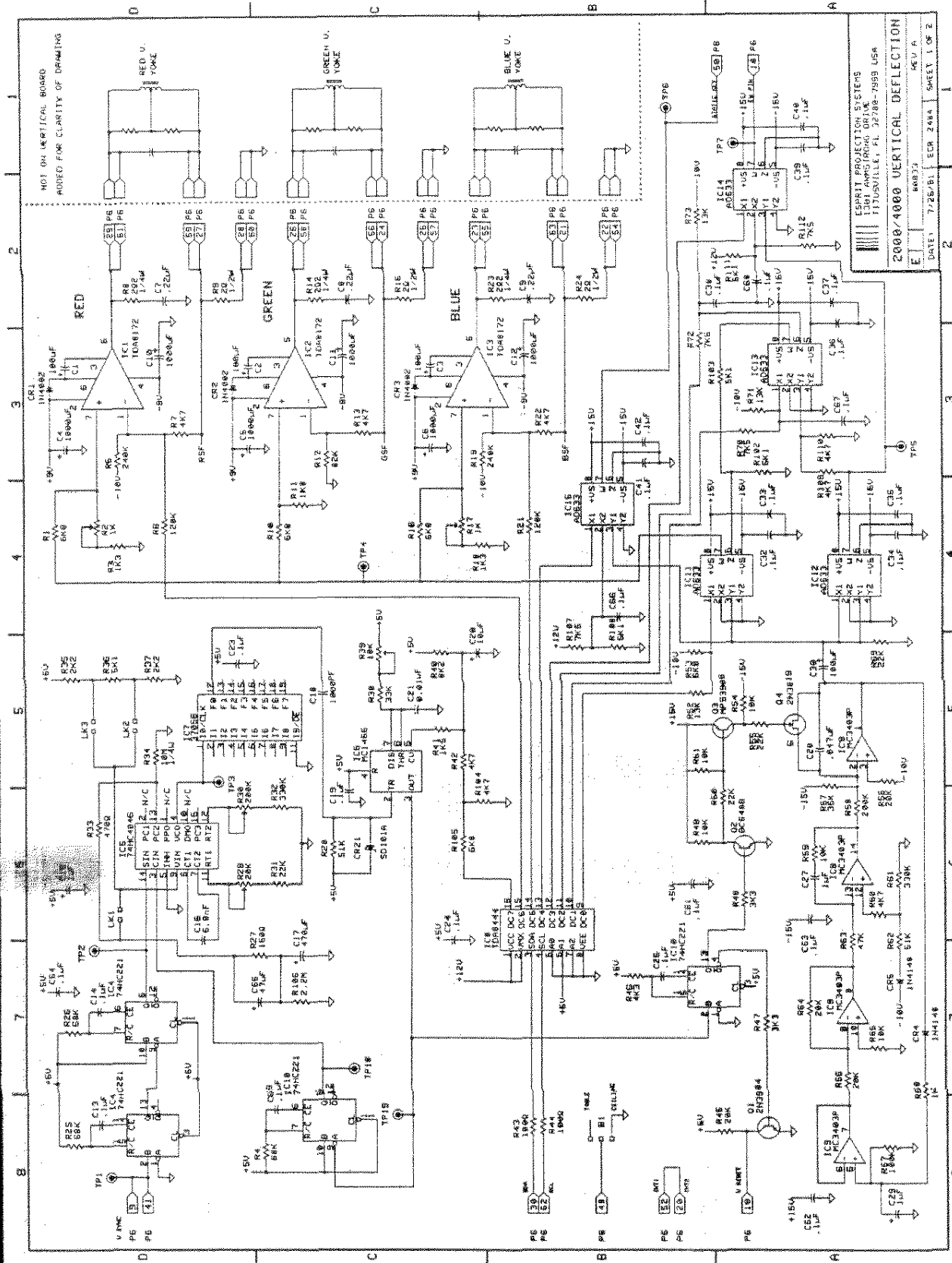

NOT ON VERTICAL BOARD
ADDED FOR CLARITY OF DRAWING

ESPRIT PRODUCTION SYSTEMS
1381 AMPS DRIVE
FITZGERALD, FL 32788-7999 USA

2000/4000 VERTICAL DEFLECTION
REV A
DATE: 7/25/81 ESR 2484 SHEET 1 OF 2

VERTICAL DEFLECTION MODULE (80833A) SCHEMATIC 1 of 2

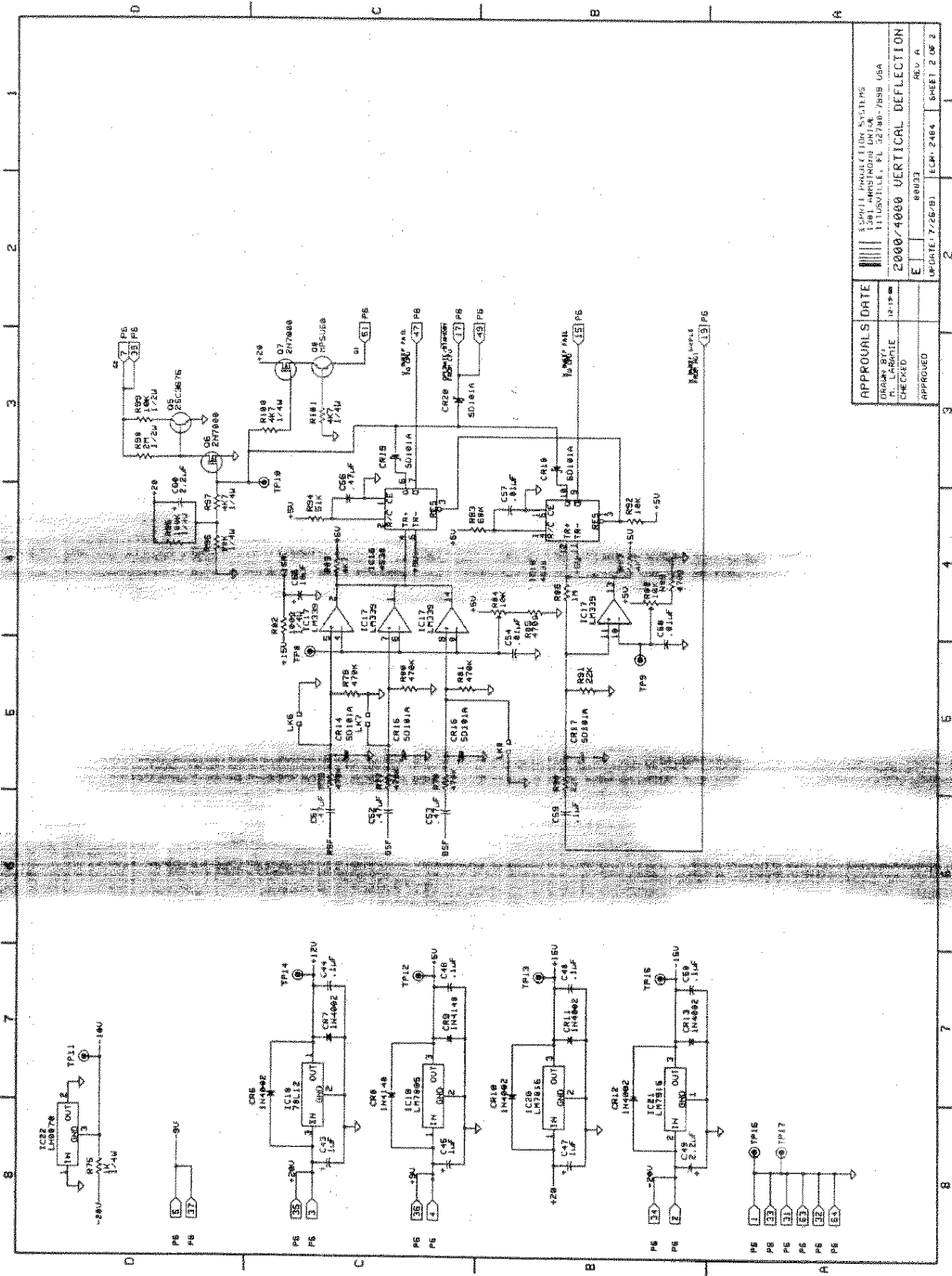

APPROVALS DATE	8/19/88	88023	ECM: 2464	SHEET 2 OF 2
DRAWN BY	H. LARANTE			
CHECKED				
APPROVED				

SUPPLIERS PRODUCTION SYSTEMS
 1361 AMPLINOVA DRIVE
 MIAMI, FL 33156
 2000/4000 VERTICAL DEFLECTION
 UPDATE: 7/26/81

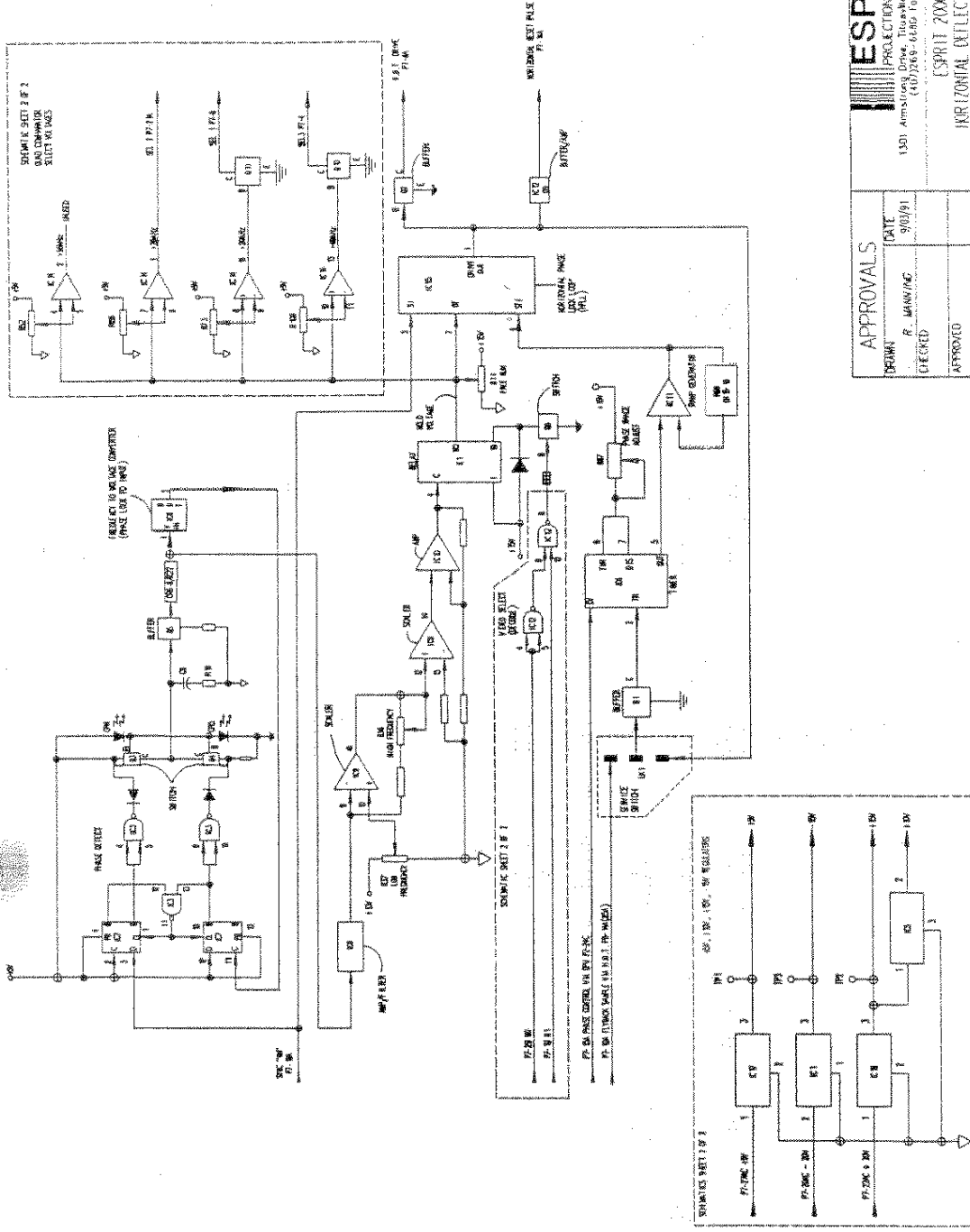

		ESPRIT PROJECTION SYSTEMS 1301 Armstrong Drive, Biscayne, FL 33290-7999 USA (407)269-6400 for 267-6211	
APPROVALS DRAWN: B. MANNING CHECKED: [] APPROVED: []		DATE: 9/01/91	
THIS DOCUMENT IS THE PROPERTY OF ESPRIT SYSTEMS. IT IS TO BE USED ONLY FOR THE PROJECT FOR WHICH IT WAS ISSUED. IT IS NOT TO BE REPRODUCED OR TRANSMITTED IN ANY FORM OR BY ANY MEANS, ELECTRONIC OR MECHANICAL, INCLUDING PHOTOCOPYING, RECORDING, OR BY ANY INFORMATION STORAGE AND RETRIEVAL SYSTEM.		ESPRIT 2000D/G HORIZONTAL DEFLECTION MODULE	
SIZE: C	DOC. NO.: 2000D - 80762A	2000G - 80732A	REV. 006
SCALE: 1:1	DO NOT SCALE DRAWING	SHEET 1 OF 1	

2000G HORIZONTAL DEFLECTION (80732A) BLOCK DIAGRAM

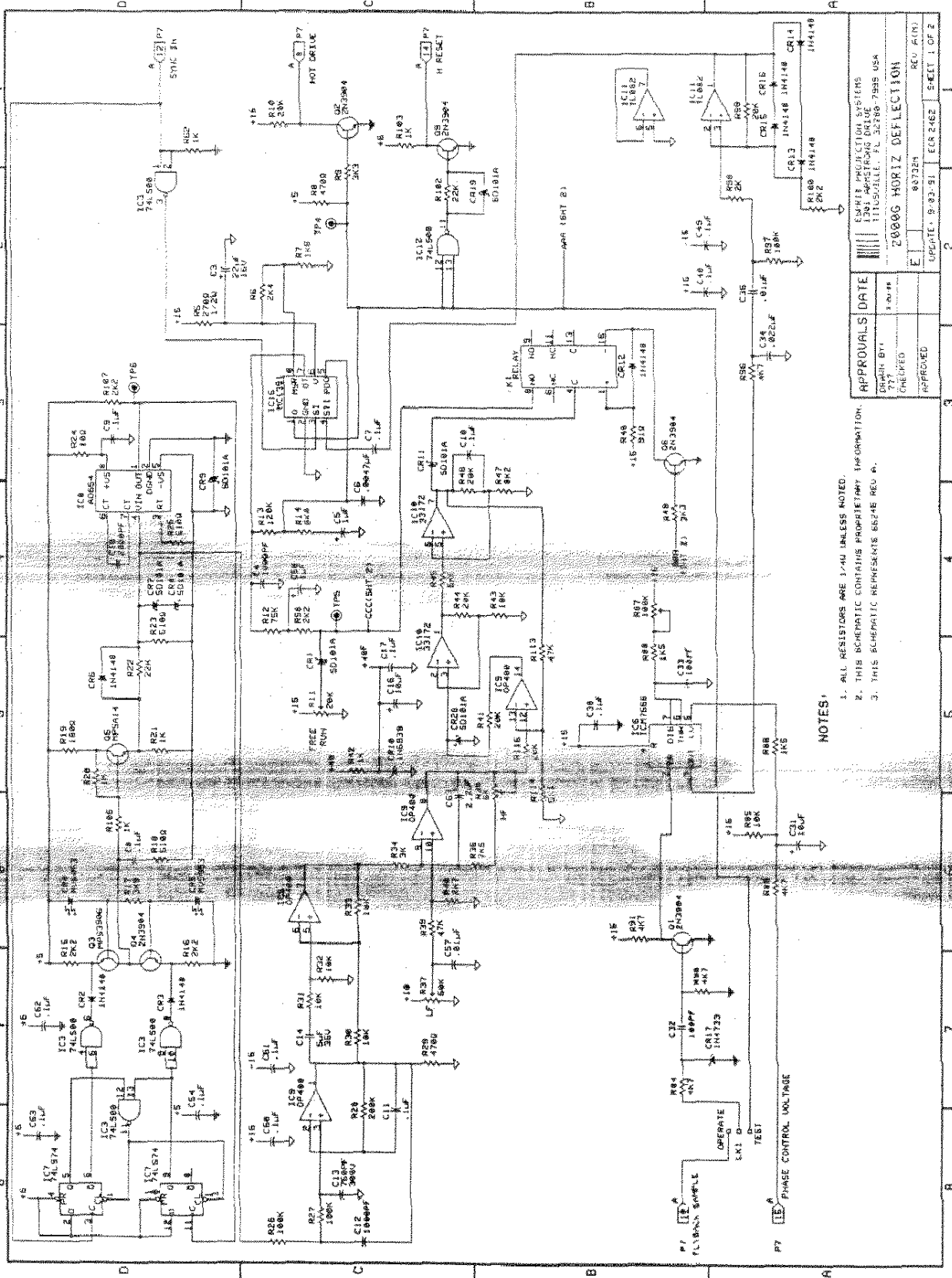

NOTES:

1. ALL RESISTORS ARE 1/4W UNLESS NOTED.
2. THIS SCHEMATIC CONTAINS PROPRIETARY INFORMATION.
3. THIS SCHEMATIC REPRESENTS REVISION 65246 REV. A.

APPROVALS DATE	DATE	BY	CHECKED	APPROVED
ESPIRIT PRODUCTION SYSTEMS 1391 APPELTON DRIVE MIAMI, FL 33186-7995 USA				
2000G HORIZ DEFLECTION				
UPDATE: 9-23-91 ECR 2462				REV. A/ND SHEET 1 OF 2

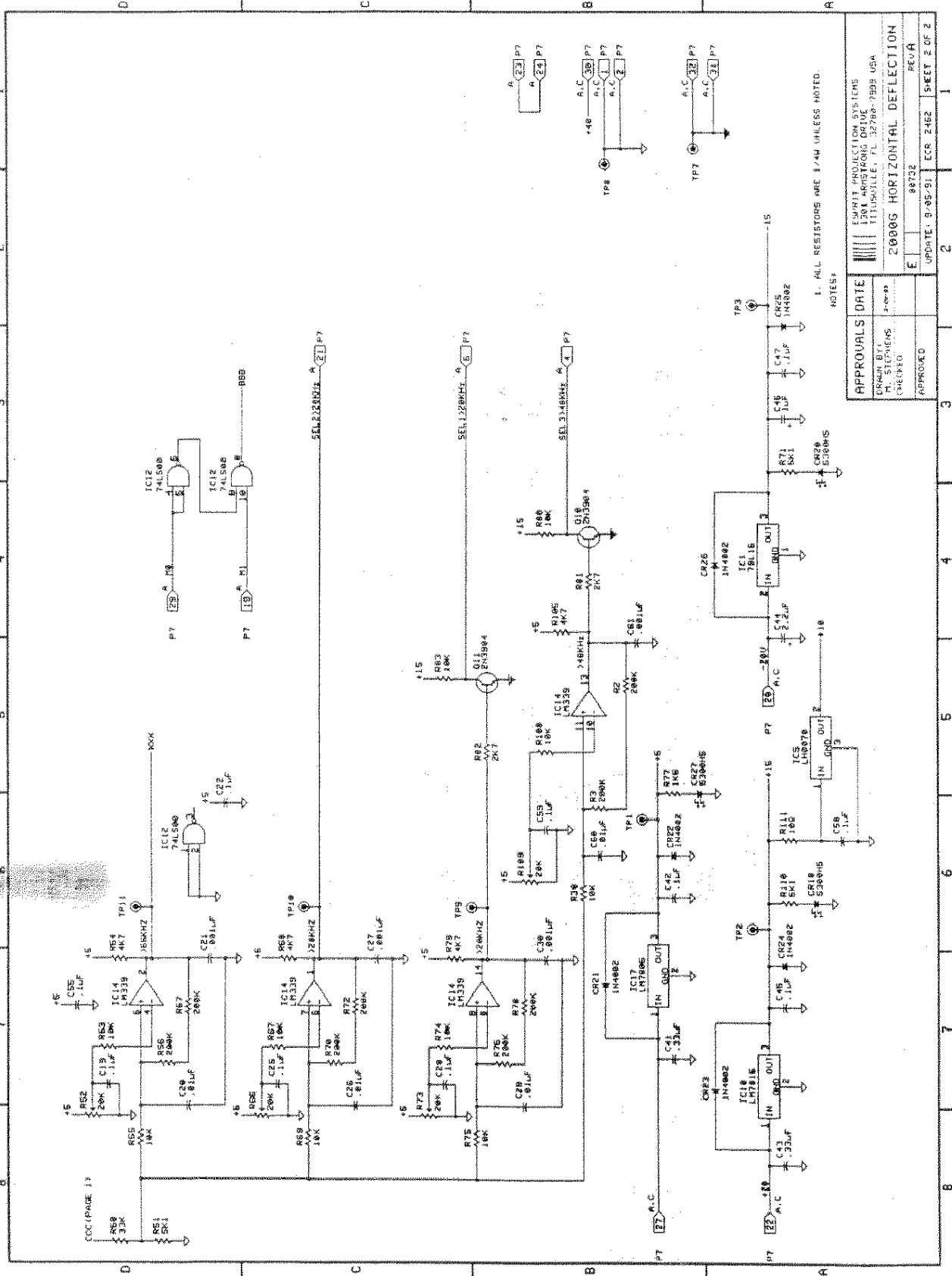

1. ALL RESISTORS ARE 1/4W UNLESS NOTED.

NOTES:

APPROVALS	DATE
DESIGNED BY	2-20-83
CHECKED	
APPROVED	

2000G HORIZONTAL DEFLECTION
 UPDATE: 9-05/91 ECR 2462 SHEET 2 OF 2
 REV A

2000G HORIZONTAL DEFLECTION (80732A) SCHEMATIC 2 of 2

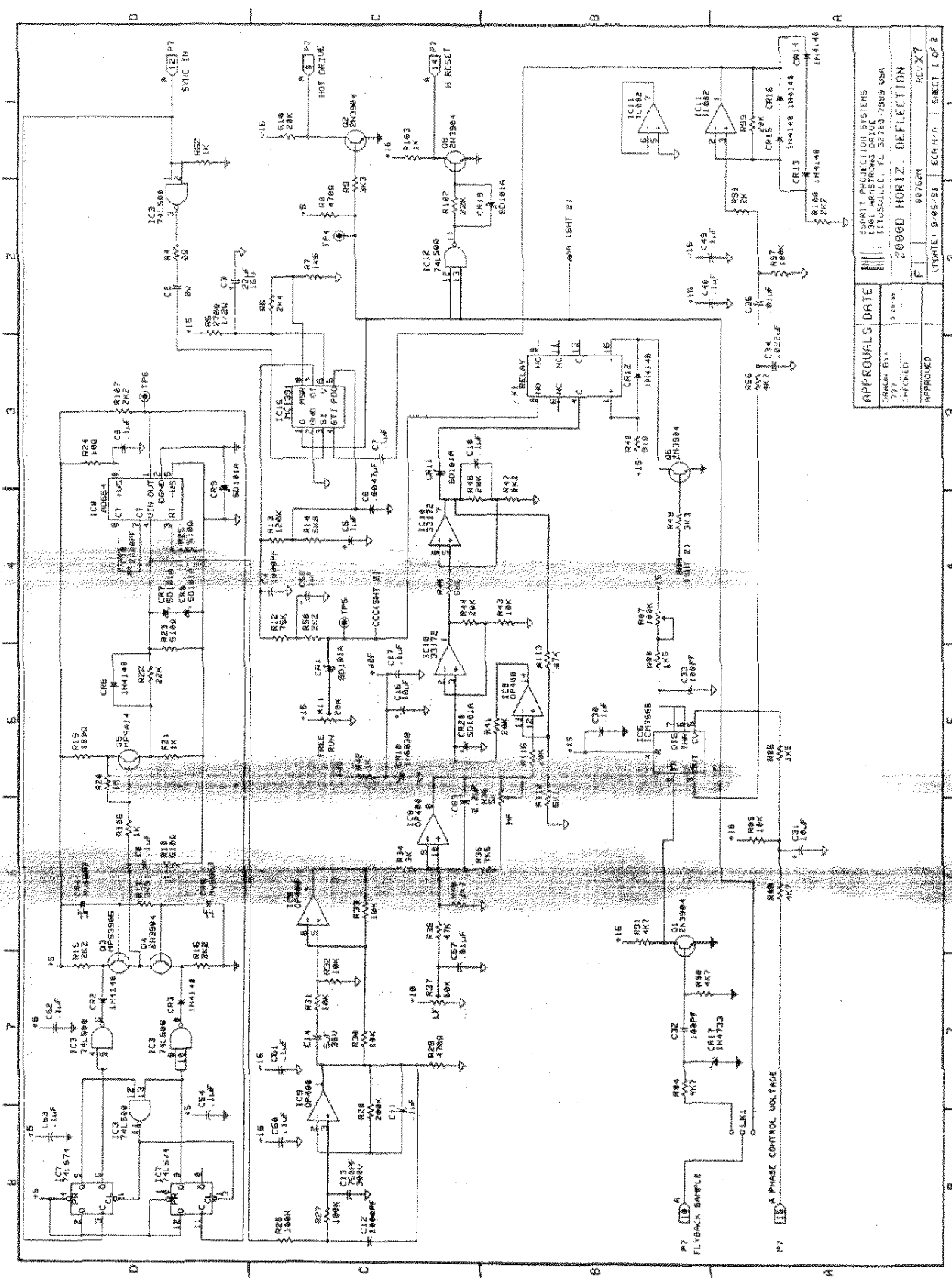

APPROVALS DATE	DATE	BY	CHECKED	APPROVED
	3/20/94			
DESIGN BY	3/20/94			
CHECKED				
APPROVED				

ESPRIT PRODUCTION SYSTEMS
11000 PRODUCTIONS DRIVE
11000 PRODUCTIONS DRIVE
26880 HORIZ. DEFLECTION

UPGRADE 9/05/91 ECR/H/A
80762X7
SHEET 1 OF 2

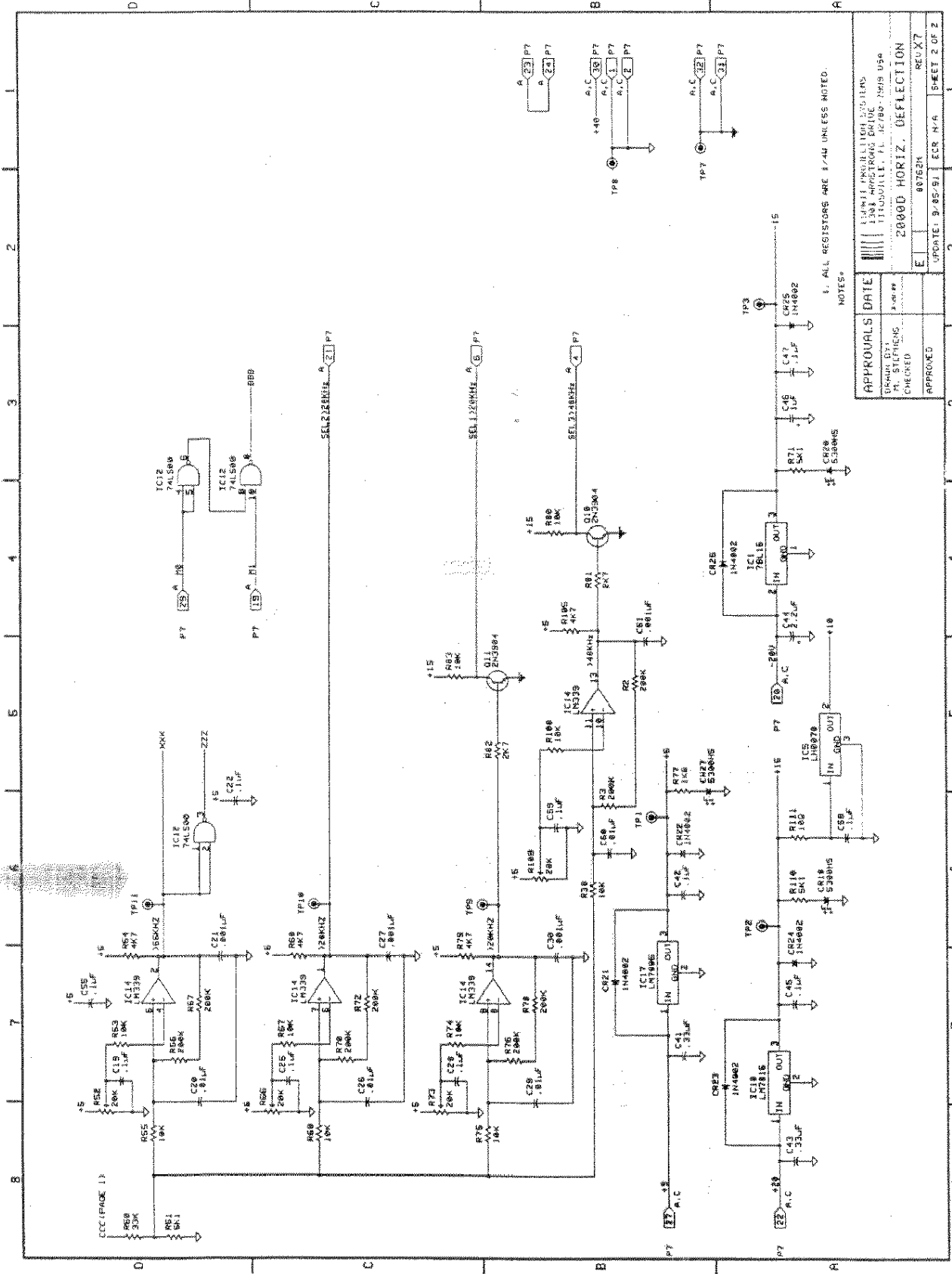

NOTES:
1. ALL RESISTORS ARE 1/4W UNLESS NOTED.

APPROVALS	DATE
DESIGNED BY	3/20/88
CHECKED BY	
APPROVED	

LHM41 PRODUCTION 2/20/88
 LHM1 PRODUCTION 8/10/88
 TTI/SOULTECH, FL 32780-7895 USA
2000D HORIZ. DEFLECTION
 80762X
 UPDATE: 3/85-91 ECR N/A
 REV X7
 SHEET 2 OF 2

2000D HORIZONTAL DEFLECTION (80762X7) SCHEMATIC 2 of 2

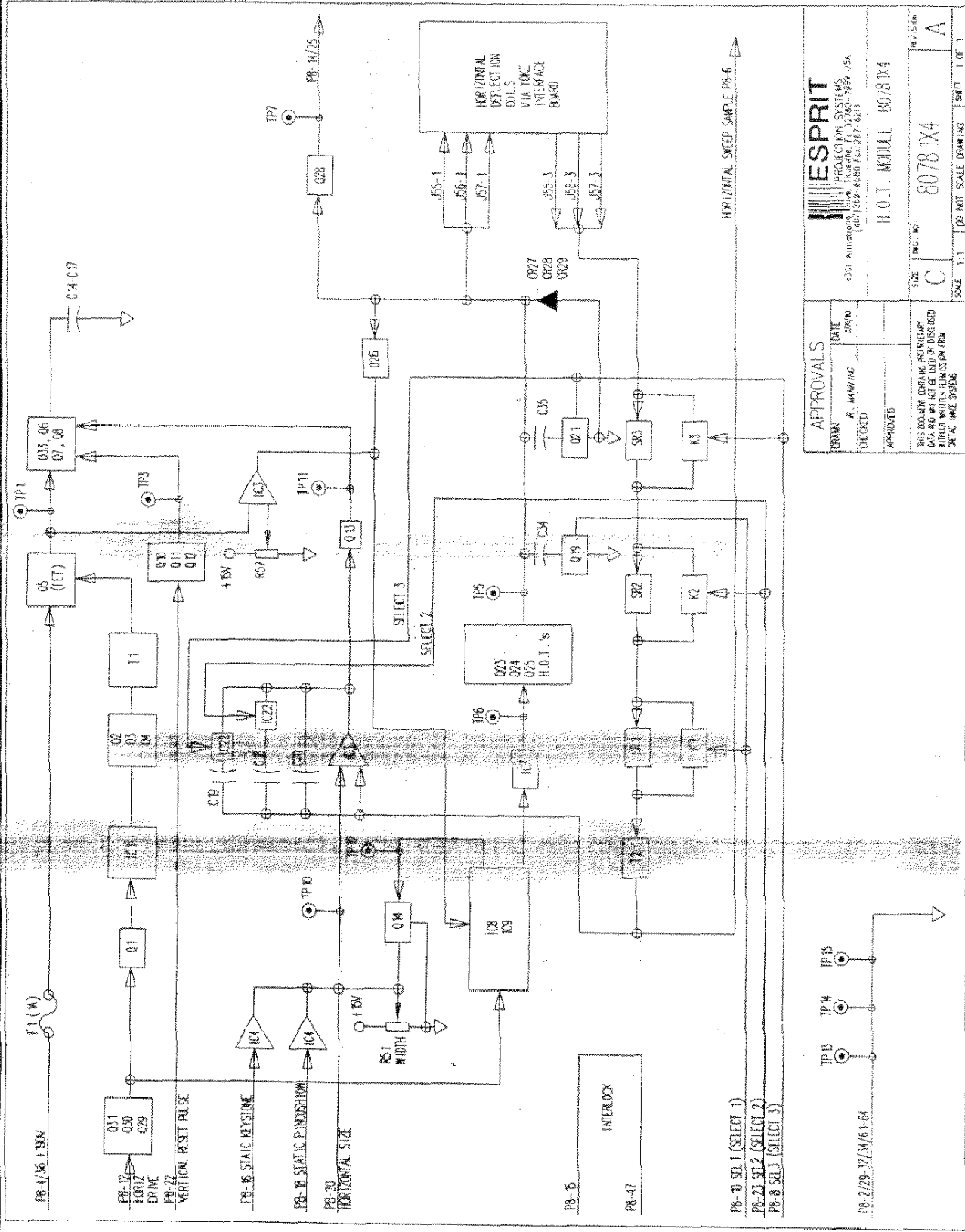

APPROVALS		DATE	
DESIGNED	DATE	BY	DATE
DRAWN	DATE	BY	DATE
CHECKED	DATE	BY	DATE
APPROVED	DATE	BY	DATE

THIS DRAWING OR ANY PART THEREOF IS UNCLASSIFIED
DATE 10/11/01 BY 60321 UCBAW/SMB/STP

ESPRIT PROJECTOR SYSTEMS
1301 Alameda Ave., Ft. Lauderdale, FL 33322-3889 USA
(407) 659-6480 Fax: 267-6311

H.O.T. MODULE 80781X4

REV: 5/84

SIZE: C INCH NO: 80781X4

SCALE: 1:1 (DO NOT SCALE DRAWING)

SHEET: 1 OF 1

H.O.T. MODULE (80781X4) BLOCK DIAGRAM

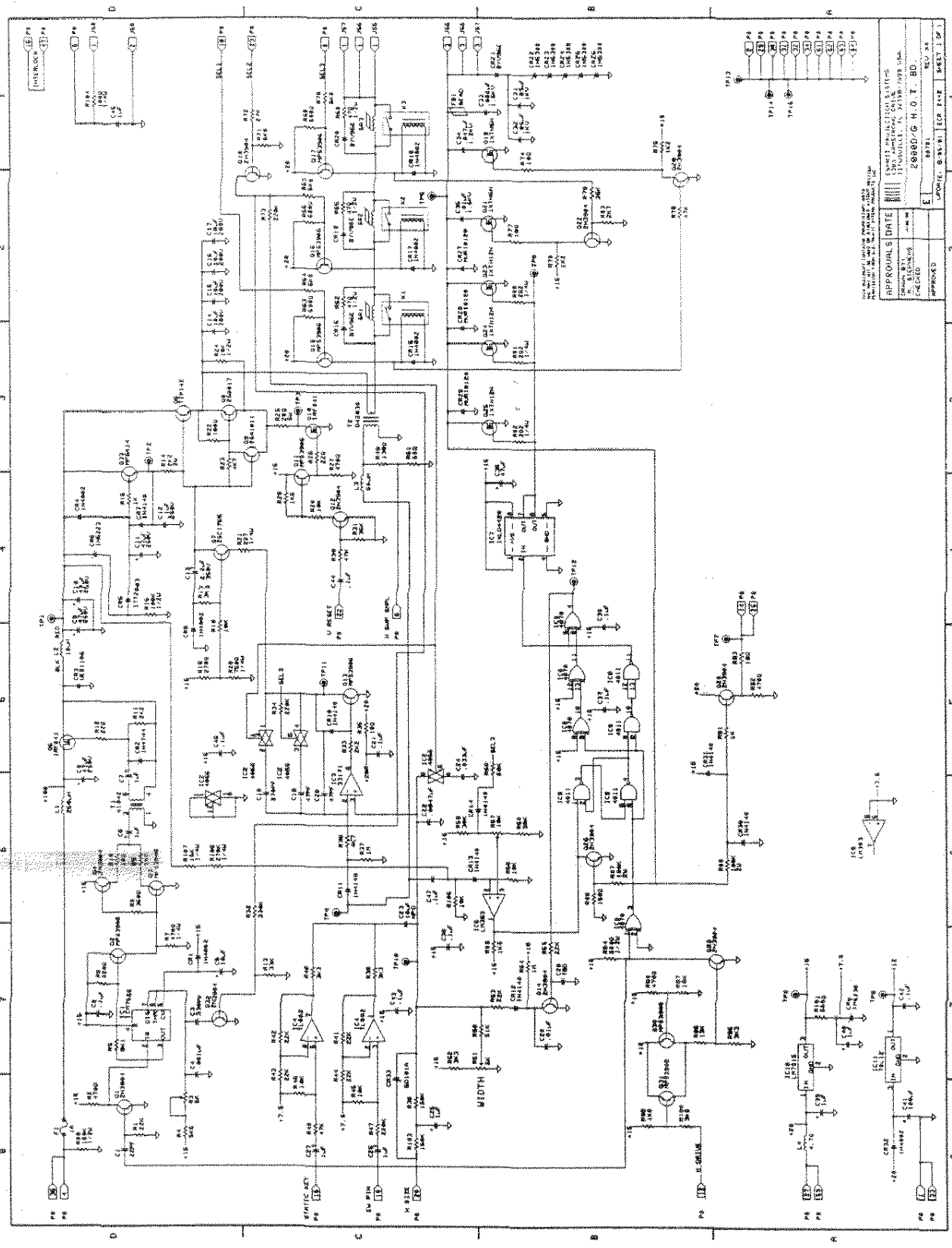

H.O.T. MODULE (80781X4) SCHEMATIC 1 of 1

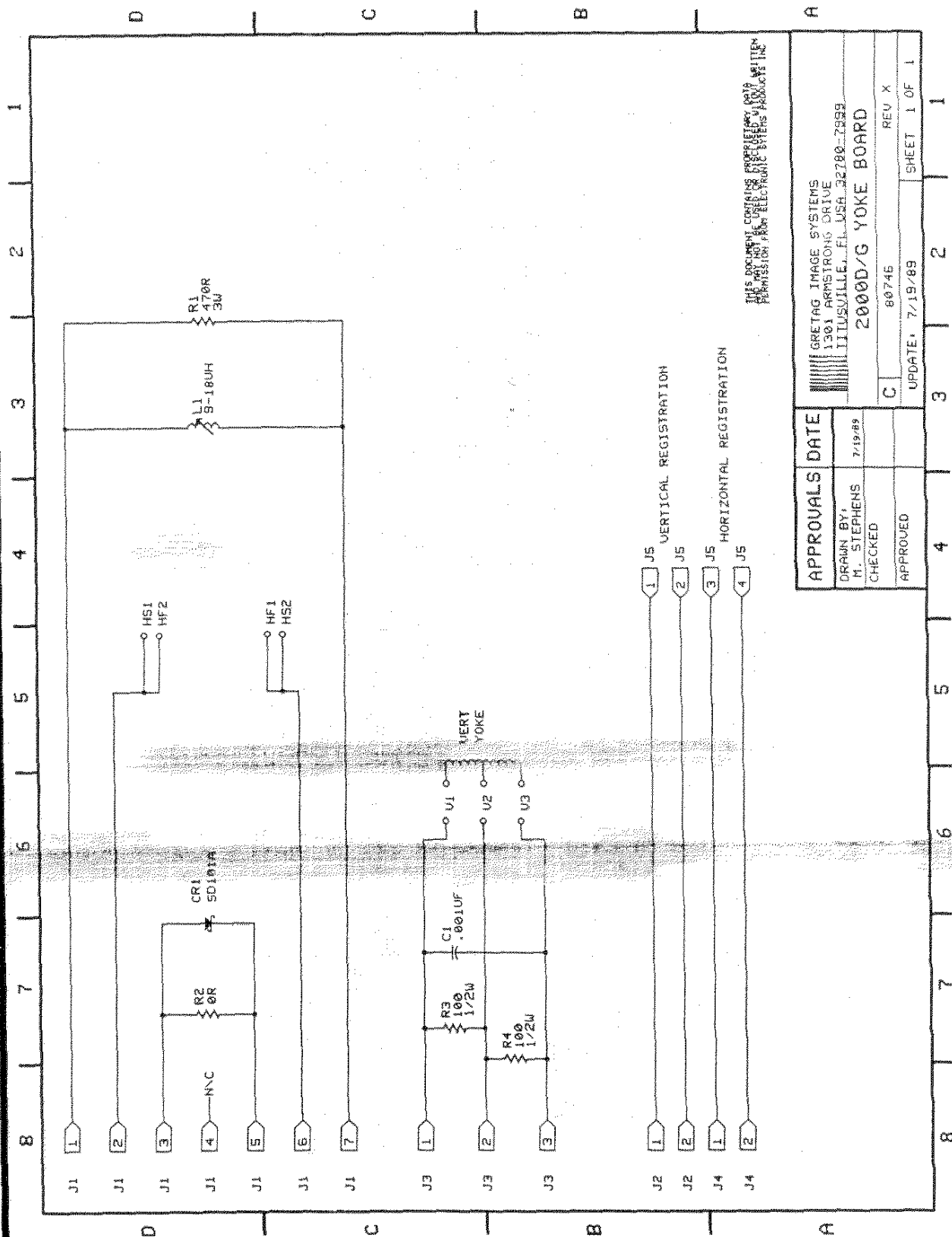

APPROVALS		DATE
DRAWN BY:	M. STEPHENS	7/19/89
CHECKED		
APPROVED		

GRETAG IMAGE SYSTEMS 1301 ARMSTRONG DRIVE JOLIET, ILLINOIS 62200-2899	
2000D/G YOKE BOARD	
C	REV X
80745	SHEET 1 OF 1
UPDATE: 7/19/89	

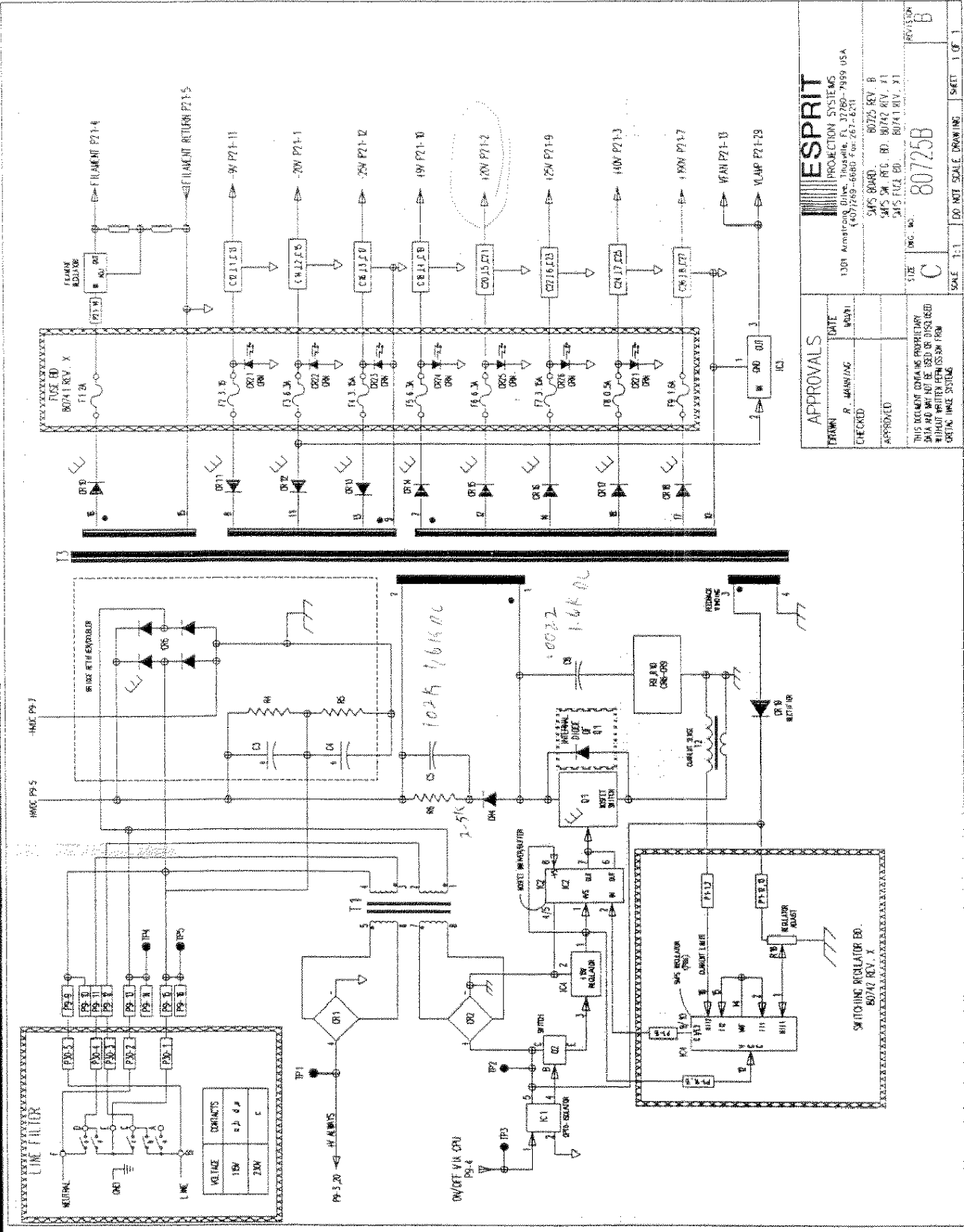

ESPRIT
PROJECTION SYSTEMS
1301 Amherst Drive
Amherst, MA 01001
Tel: 407-7999 USA

APPROVALS

DRAWN	DATE
R. WAINWAG	11/81
CHECKED	
APPROVED	

THIS DOCUMENT IS THE PROPERTY OF ESprit SYSTEMS. IT IS TO BE USED ONLY FOR THE INTENDED PURPOSE.

SIZE: C
REV: 80725B
SCALE: 1:1
SHEET: 1 OF 1

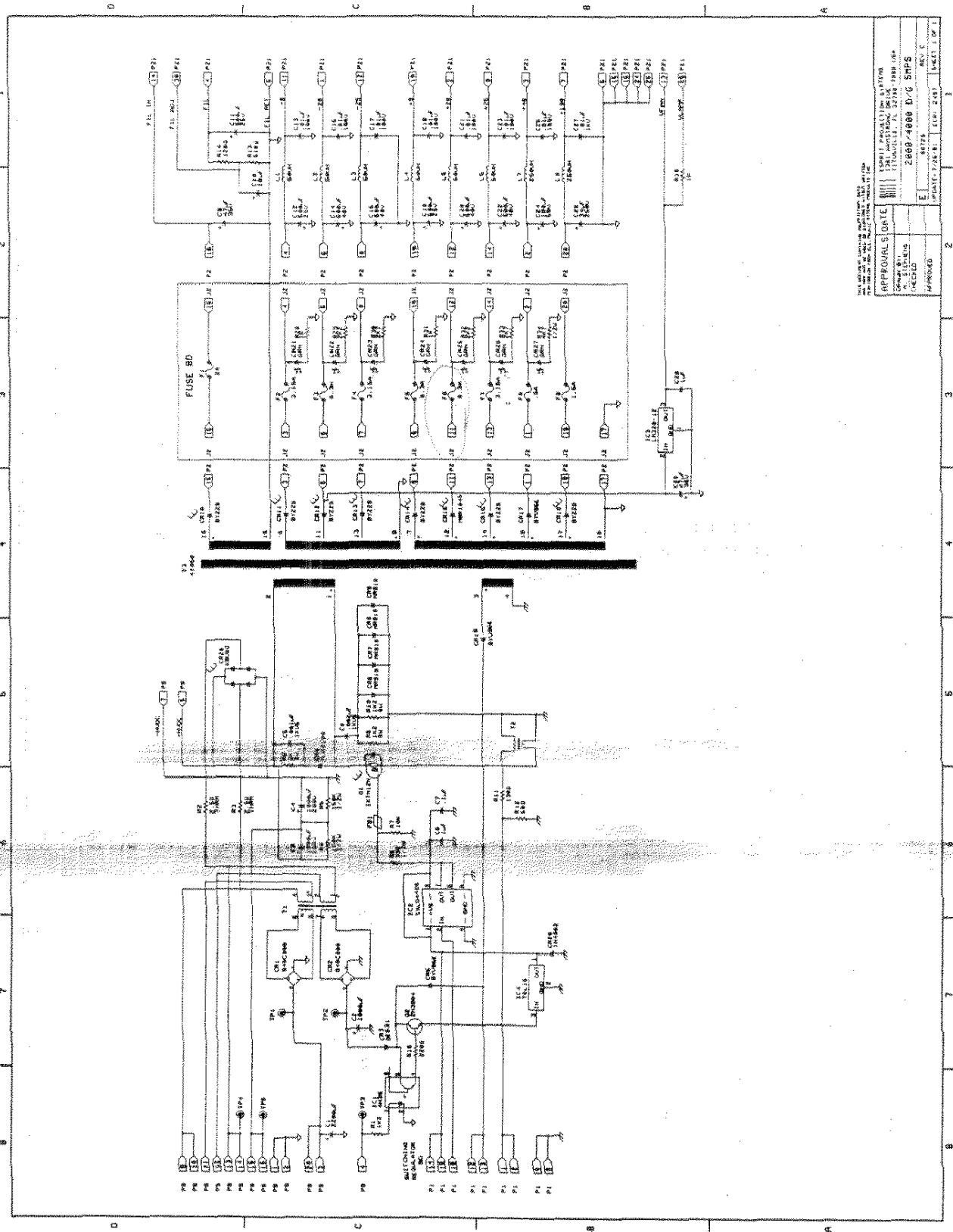

ESPRIT 2000D/G TECHNICAL REFERENCE MANUAL
ESPRIT 2000D/G TECHNICAL REFERENCE MANUAL
ESPRIT 2000D/G TECHNICAL REFERENCE MANUAL

APPROVALS DATE	
DESIGNED BY	ESPRIT 2000D/G TECHNICAL REFERENCE MANUAL
CHECKED BY	ESPRIT 2000D/G TECHNICAL REFERENCE MANUAL
APPROVED BY	ESPRIT 2000D/G TECHNICAL REFERENCE MANUAL

2000-4088 D/G SMPS
REV. C
DATE: 08/22/00
PAGE: 2/37
SHEET: 1 OF 1

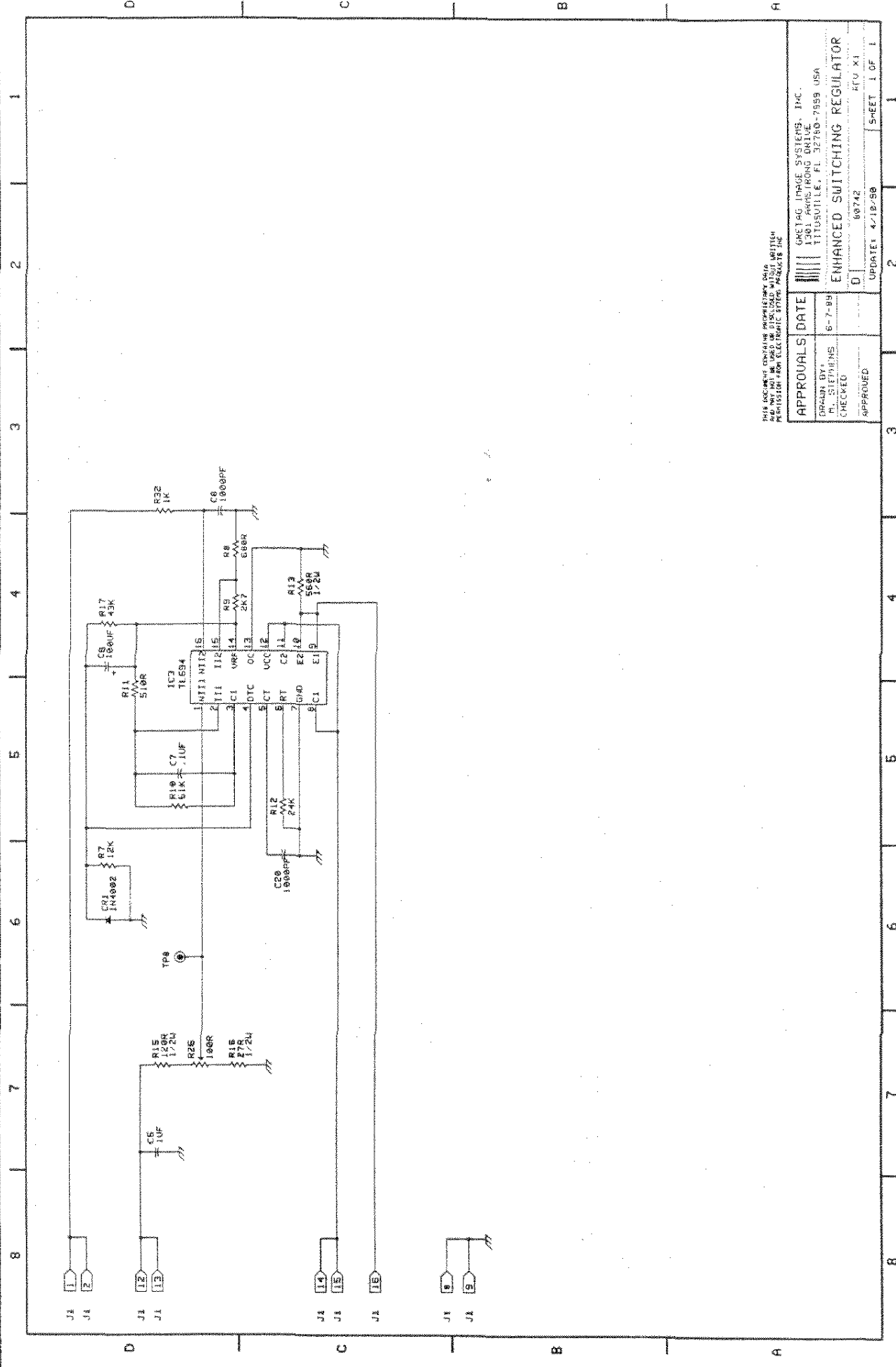

THIS DOCUMENT CONTAINS PROPRIETARY DATA
 WHICH IS UNCLASSIFIED EXCEPT WHERE SHOWN
 OTHERWISE BY A CONTROLLED DATA LABEL

APPROVALS	DATE	BY
DRAWN BY	6-7-99	M. STEPHENS
CHECKED		
APPROVED		

80742
 UPDATE 4/18/99
 SHEET 1 OF 1

SMPS REGULATOR (80742X1) SCHEMATIC 1 of 1

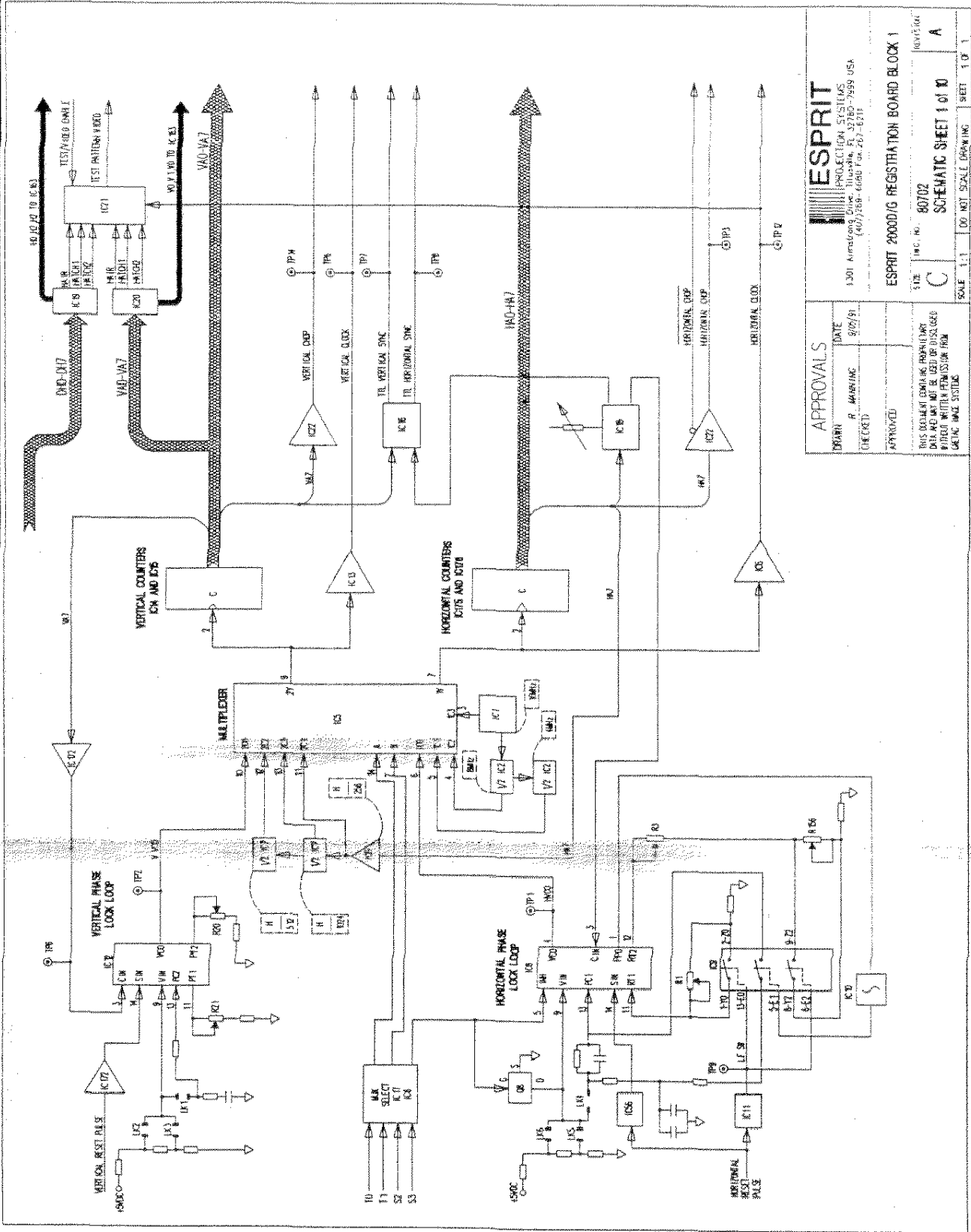

ESPRIT PROJECTION SYSTEMS 1301 Armstrong Drive, Bluevale, PA 37801-7599 USA (607) 568-4600 Fax: (607) 568-6311		ESPRIT 2000D/G REGISTRATION BOARD BLOCK 1 SIZE: INC. NO. 80702 SCHEMATIC SHEET 1 of 10 SCALE: 1:1 DO NOT SCALE DRAWING	
APPROVALS DRAWN: [] DATE: 9/29/91 CHECKED: [] APPROVED: []		THIS DOCUMENT CONTAINS PROPRIETARY DATA AND MUST NOT BE COPIED OR DISCLOSED WITHOUT WRITTEN PERMISSION FROM THE IAC AND ESprit	

REGISTRATION BOARD (80702B) BLOCK DIAGRAM 1

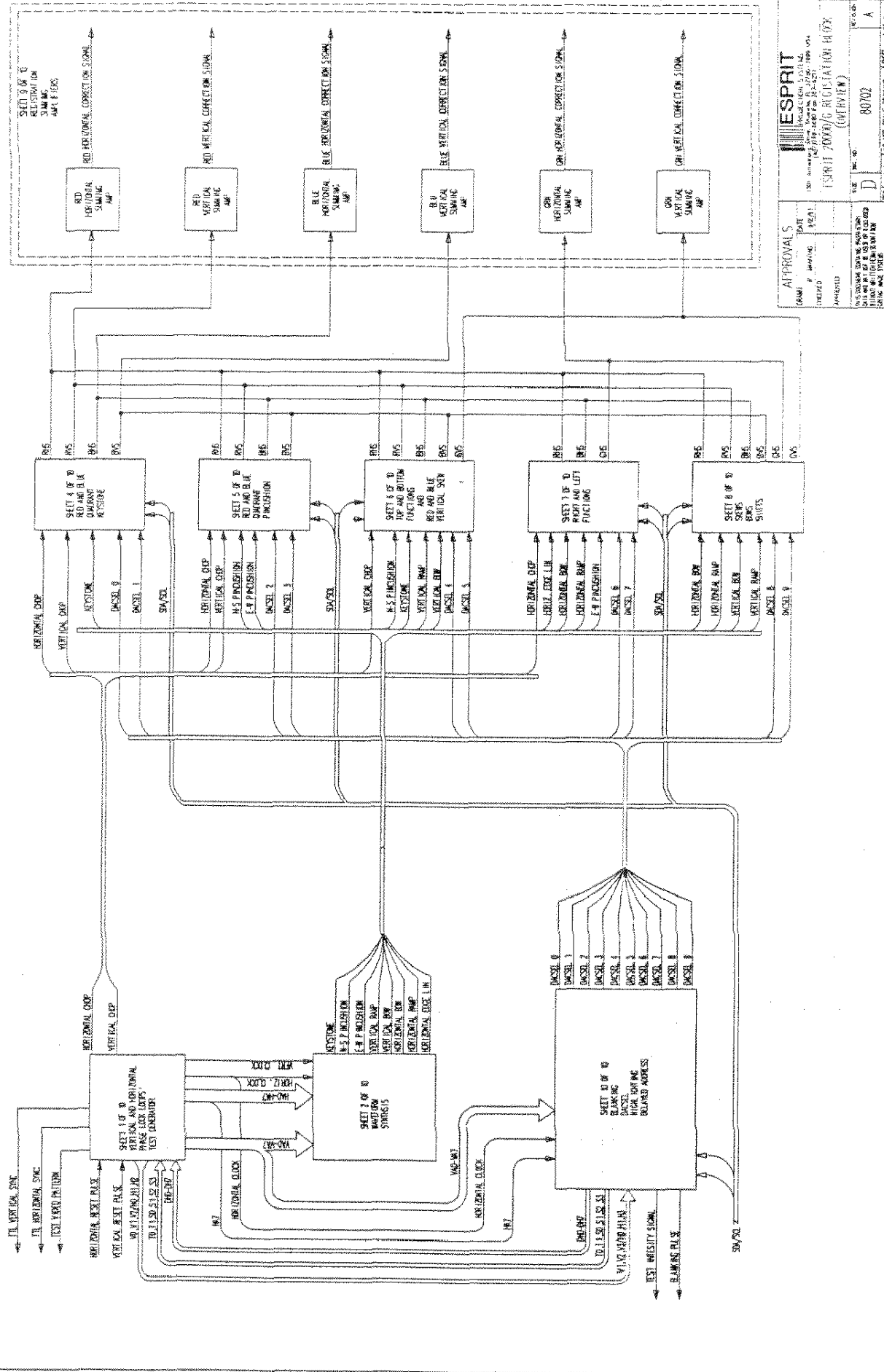

ESPRIT
 3000 Series
 ES-2000/G REGISTRATION BOARD
 (OVERVIEW)

APPROVALS	DATE	REV	NO
DESIGNED BY	DATE	D	80702
APPROVED BY	DATE		

U.S. GOVERNMENT WORKING
 THIS DOCUMENT IS IN THE PUBLIC DOMAIN
 AND IS AVAILABLE TO THE PUBLIC
 WITHOUT LIMITATION

ESPRIT 2000/G REGISTRATION BOARD
 SHEET 13 OF 13

REGISTRATION BOARD (80702B) BLOCK DIAGRAM 2

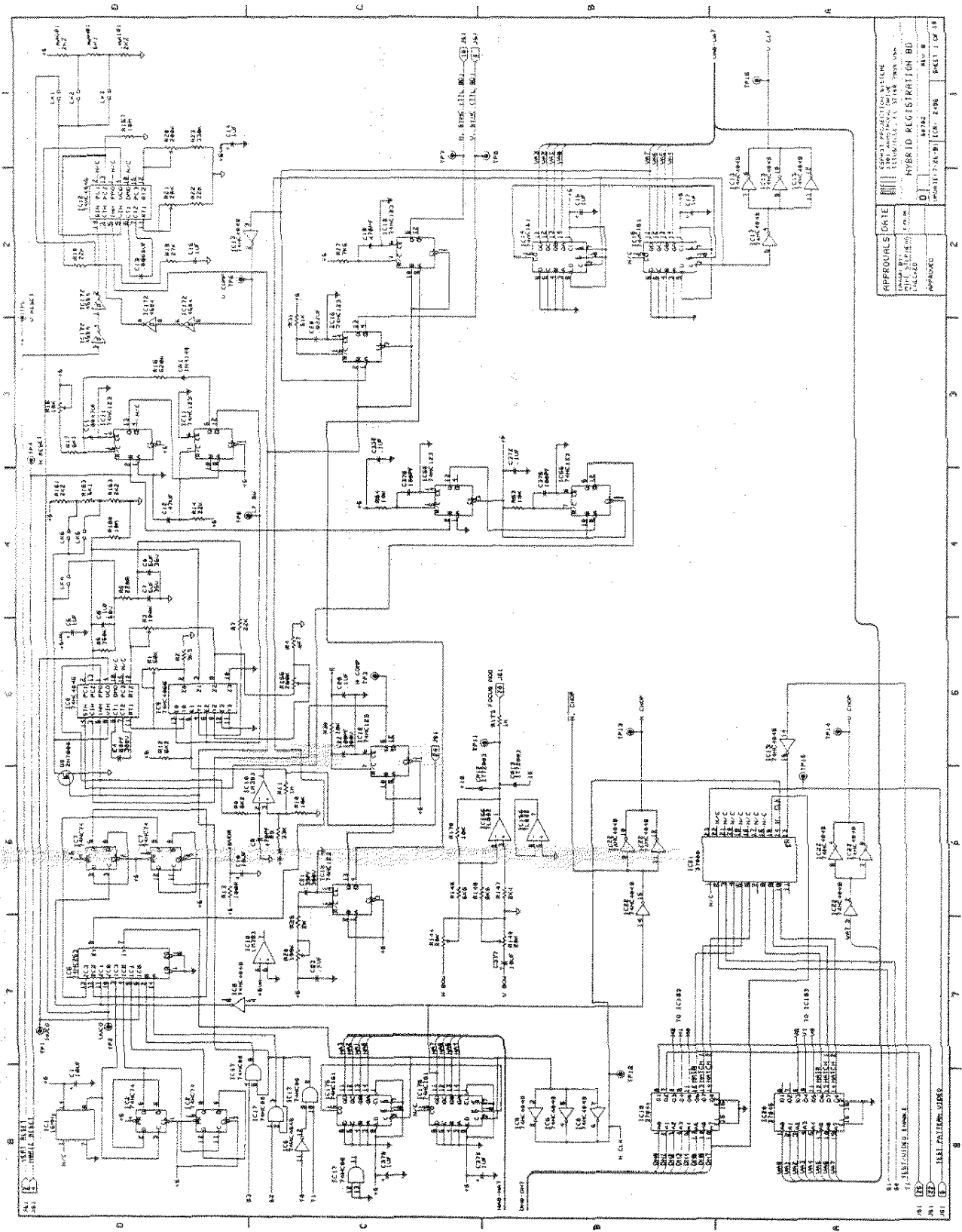

REGISTRATION BOARD (80702B) SCHEMATIC 1 of 10

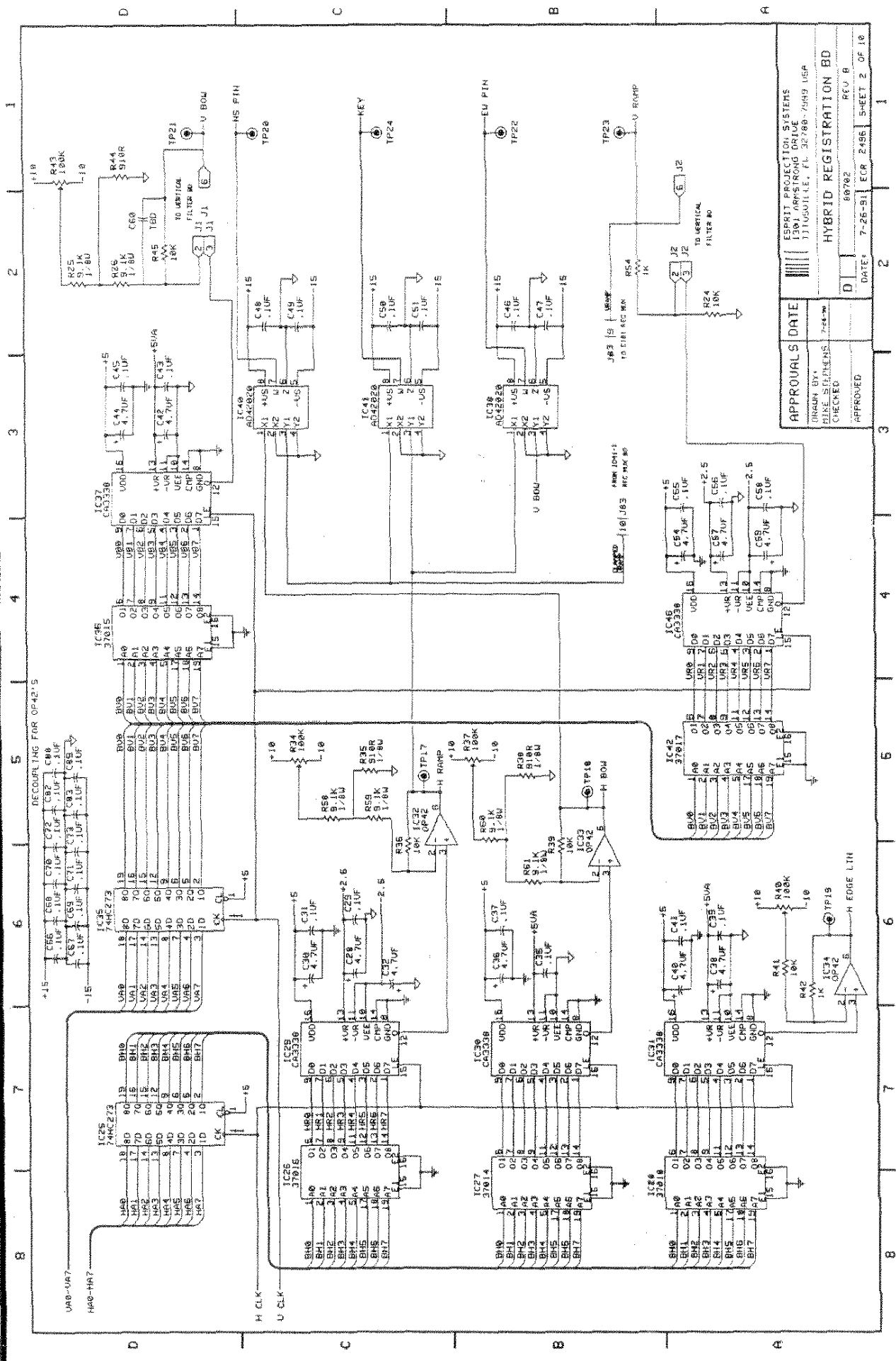

REGISTRATION BOARD (80702B) SCHEMATIC 2 of 10

APPROVALS DATE: _____
 DESIGNED BY: _____
 DRAWN BY: _____
 CHECKED: _____
 APPROVED: _____

DATE: 7-26-91 ECR 2496 SHEET 2 OF 10

ESPRIT PROJECTION SYSTEMS
 1301 ARMSTRONG DRIVE
 JEFFERSONVILLE, IN 47130-1111

HYBRID REGISTRATION BD
 REV. B

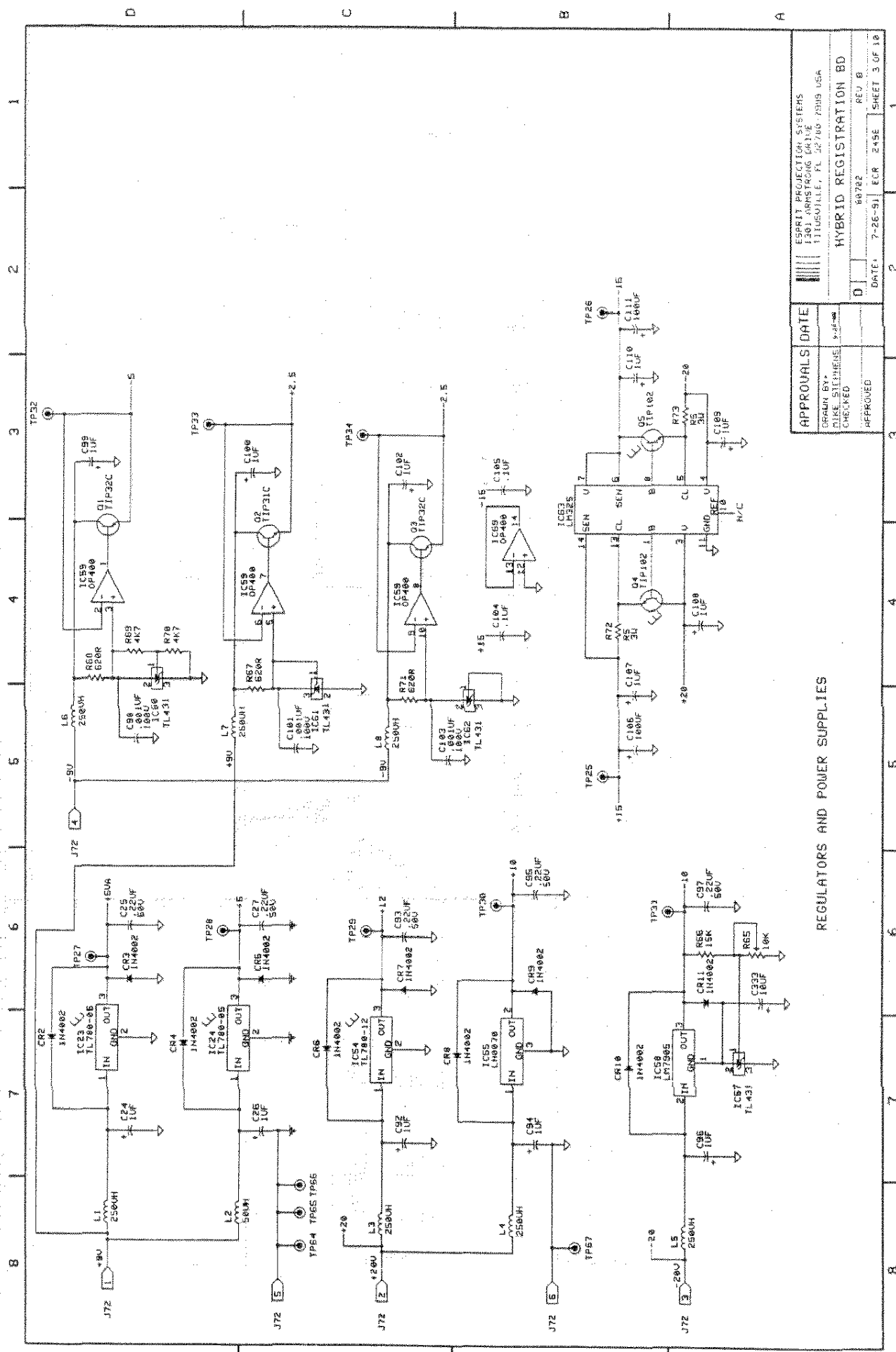

REGULATORS AND POWER SUPPLIES

APPROVALS		DATE
DESIGNED BY D. K. STEPHENS	DATE: 7-26-91	ECR 2456
CHECKED	REV 8	SHEET 3 OF 10
ESPRIT PRODUCTION SYSTEMS 11166 WILSON BLVD 11166 WILSON BLVD HYBRID REGISTRATION BD		

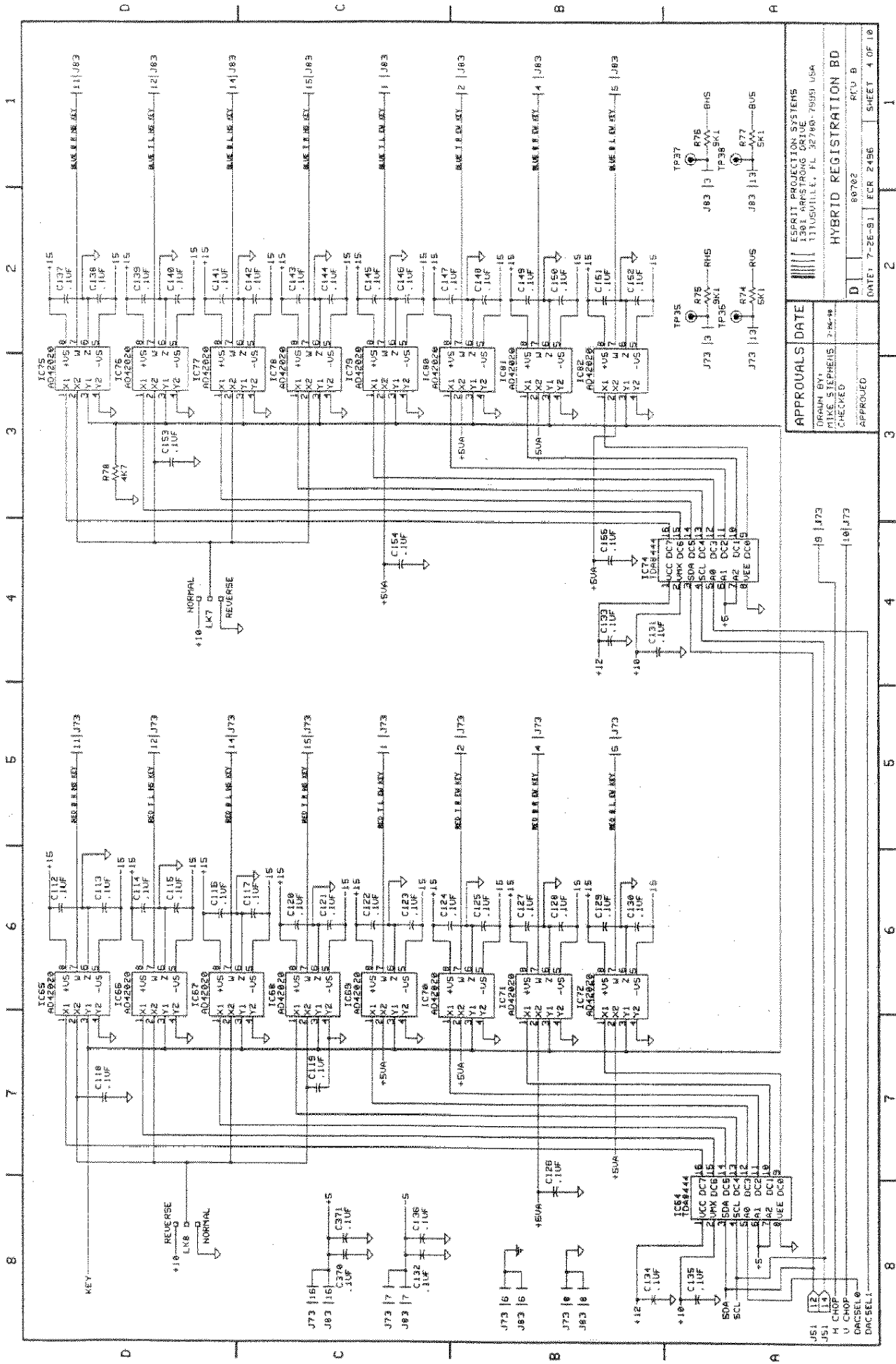

APPROVALS DATE		DATE: 7-26-81	
DESIGNED BY	TP-66-88	DATE	7-26-81
CHECKED		ECR	2486
APPROVED		SHEET	4 OF 10

HYBRID REGISTRATION BD	
ESPRIT PROJECTION SYSTEMS	1301 ARMSTRONG DRIVE
	TITUSVILLE, FL 32780-7593 USA
ORIGIN BY	TP-66-88
CHECKED	
APPROVED	
DATE	7-26-81
ECR	2486
SHEET	4 OF 10

REGISTRATION BOARD (80702B) SCHEMATIC 4 of 10

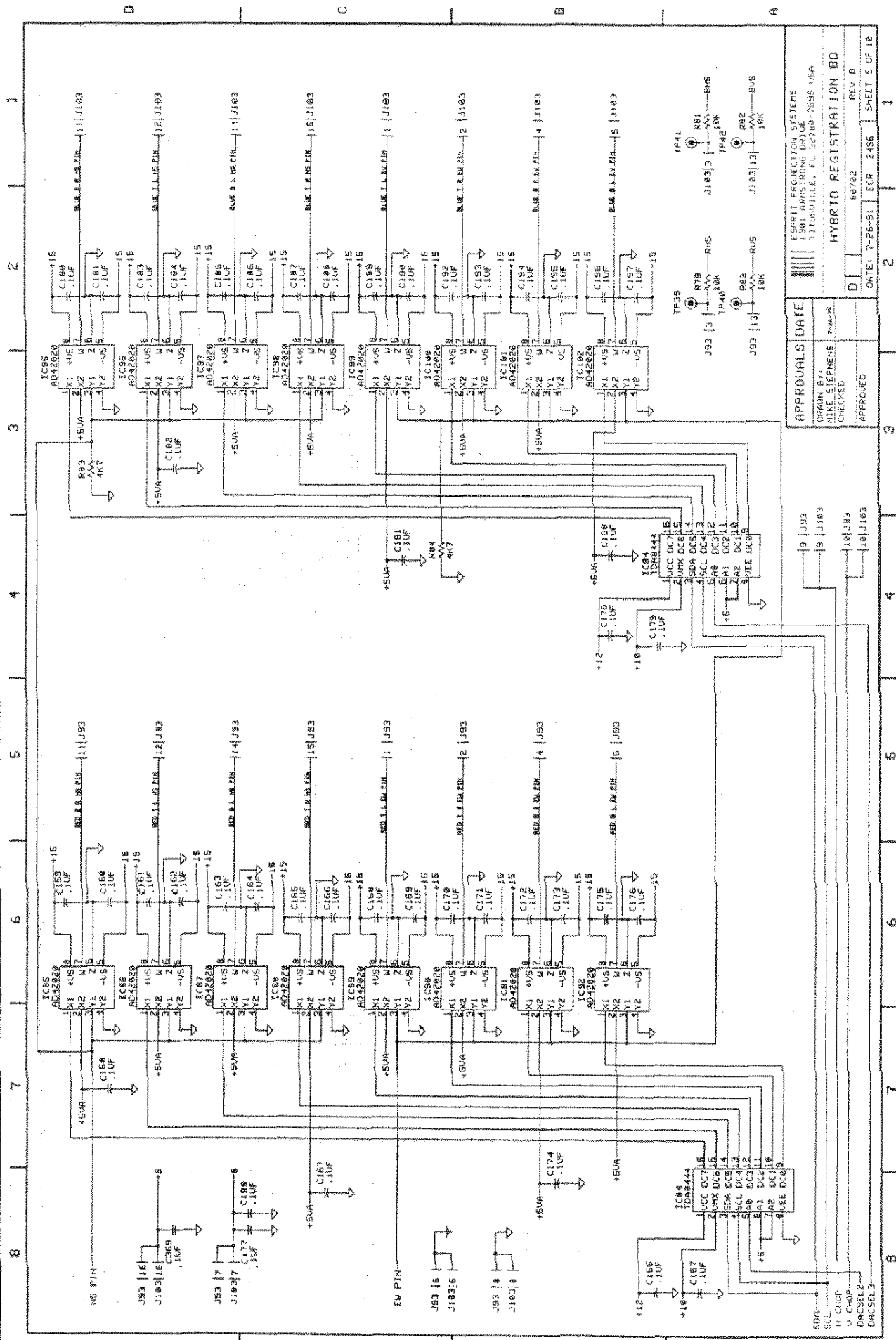

APPROVALS	DATE	BY
DESIGNED	6/7/92	TCJ
CHECKED		
APPROVED		

ESPRIT PROJECTION SYSTEMS
1301 AARSTRONG DRIVE
TITUSVILLE, FL 32780-7959 USA

HYBRID REGISTRATION BD

DATE: 7-26-91 ECR 2456 SHEET 5 OF 16

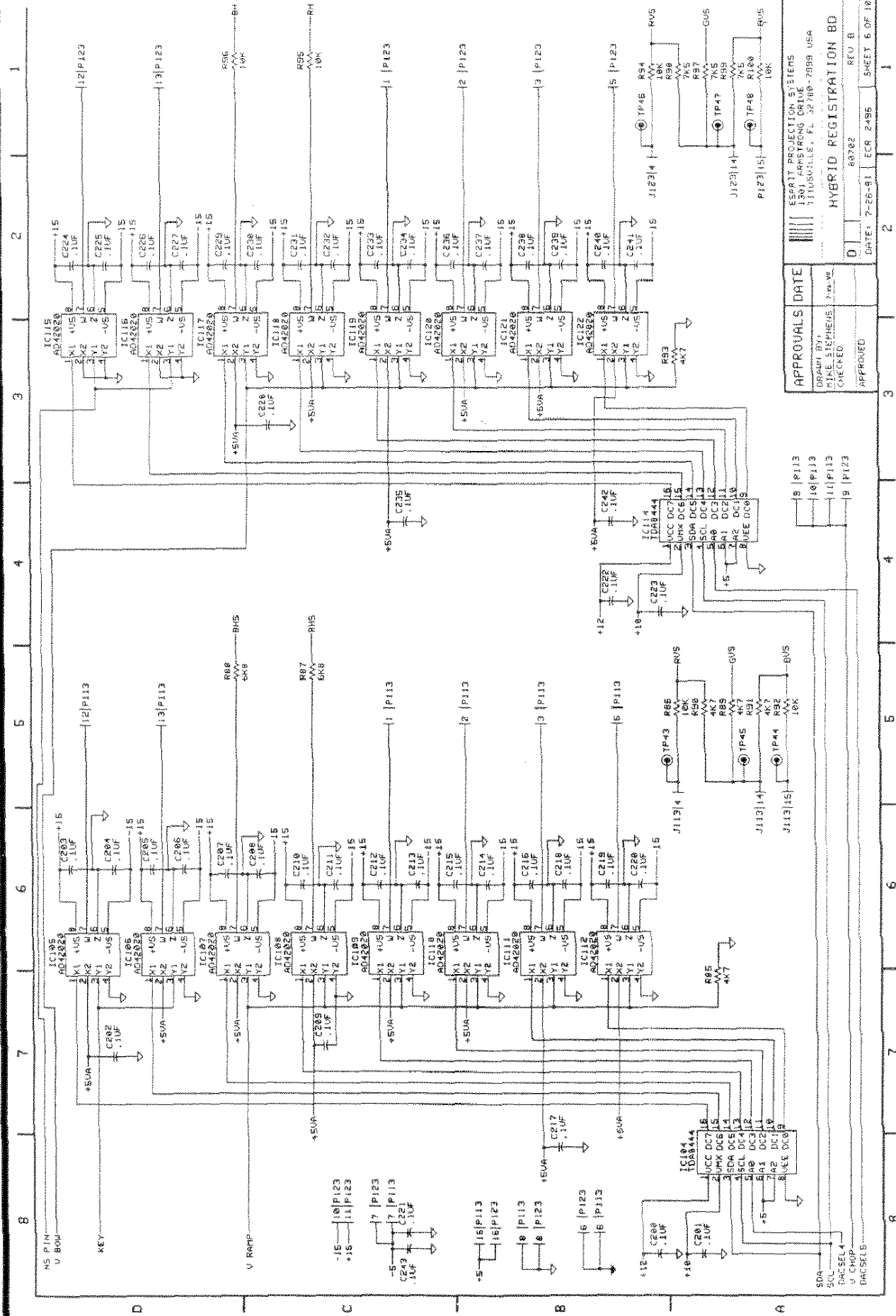

REGISTRATION BOARD (80702B) SCHEMATIC 6 of 10

APPROVALS	DATE
DESIGNED BY PIKE STEPHENS	7-9-92
CHECKED	
APPROVED	

ESPRIT PROJECTION SYSTEMS 1301 HARRISON DRIVE 11105VILLE, FL 32789-7899 USA	
HYBRID REGISTRATION BD	
REV B	80702
DATE: 7-26-91	ECR 2495
SHEET 6 OF 10	

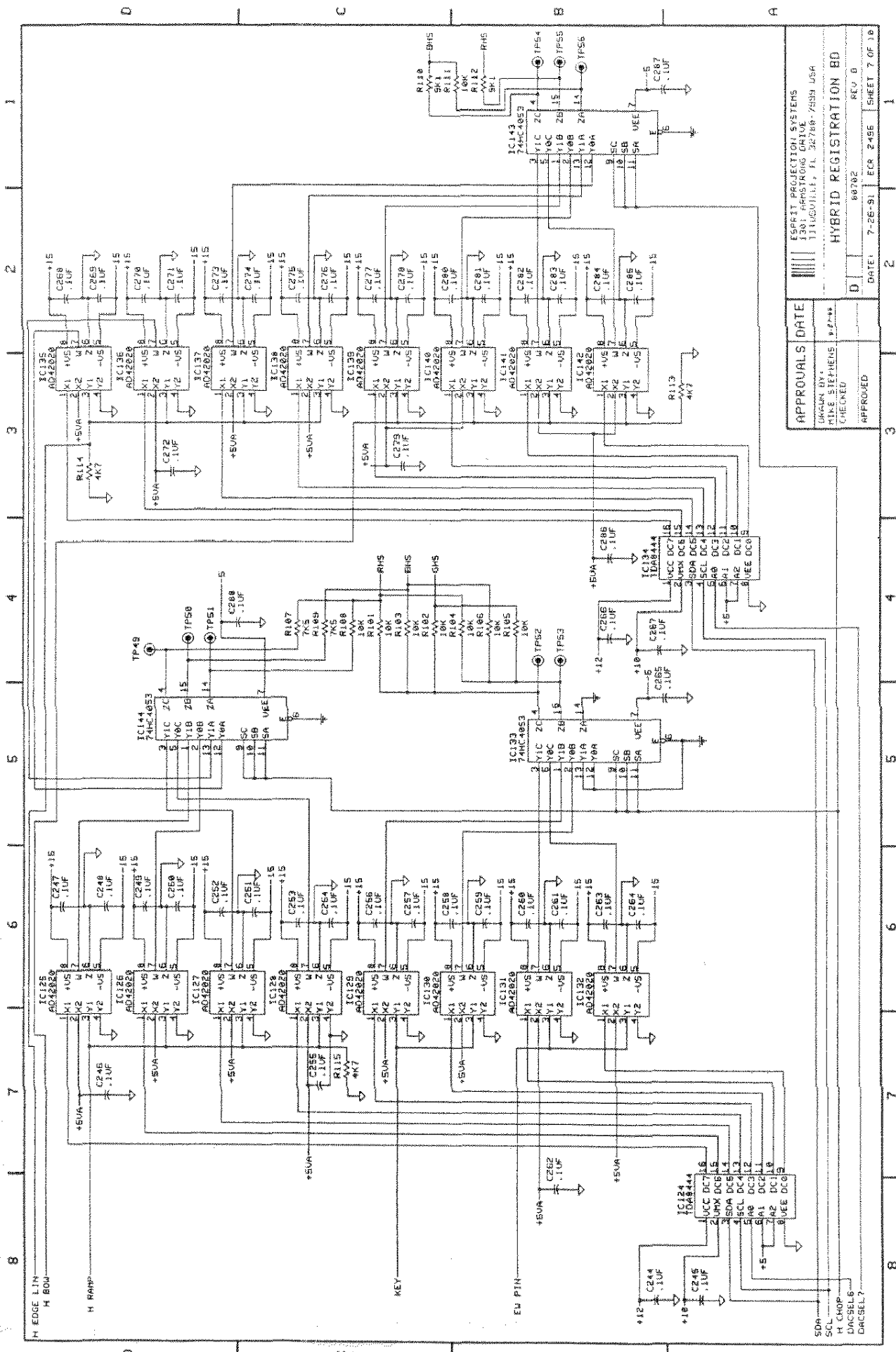

APPROVALS	DATE	DATE	DATE	DATE
UNAPPROVED	UNAPPROVED	UNAPPROVED	UNAPPROVED	UNAPPROVED
DATE: 7-26-91	ECR 2456	SHEET 7 OF 18	REV. B	

ESPRIT PROJECTION SYSTEMS
 1301 ARMSTRONG DRIVE
 JENNINGSVILLE, FL 32759-7859 USA

HYBRID REGISTRATION BD

80702

SDA
 SOL
 H CHOP
 H CHOP
 H CHOP
 DACSEL6
 DACSEL7

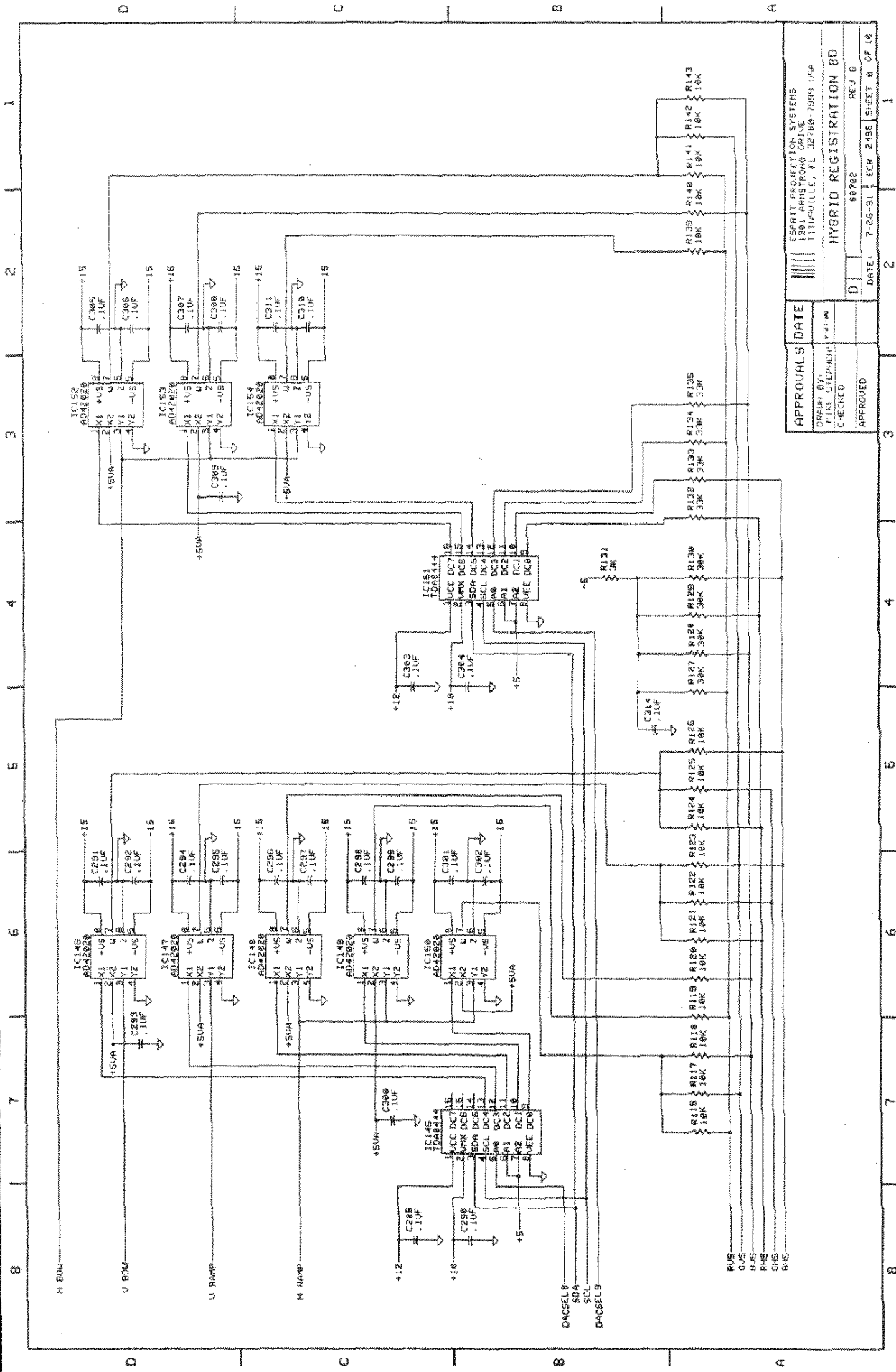

APPROVALS DATE		ESPRIT PRODUCTION SYSTEMS 1301 ARMSTRONG DRIVE TITUSVILLE, FL 32780-7889 USA	
DESIGNED BY DAN LUTHEMUS	DATE 08/28/82	HYBRID REGISTRATION BD	
CHECKED	APPROVED	REV. 0	DATE 7-26-91
			ECR 2486 SHEET 8 OF 10

REGISTRATION BOARD (80702B) SCHEMATIC 8 of 10

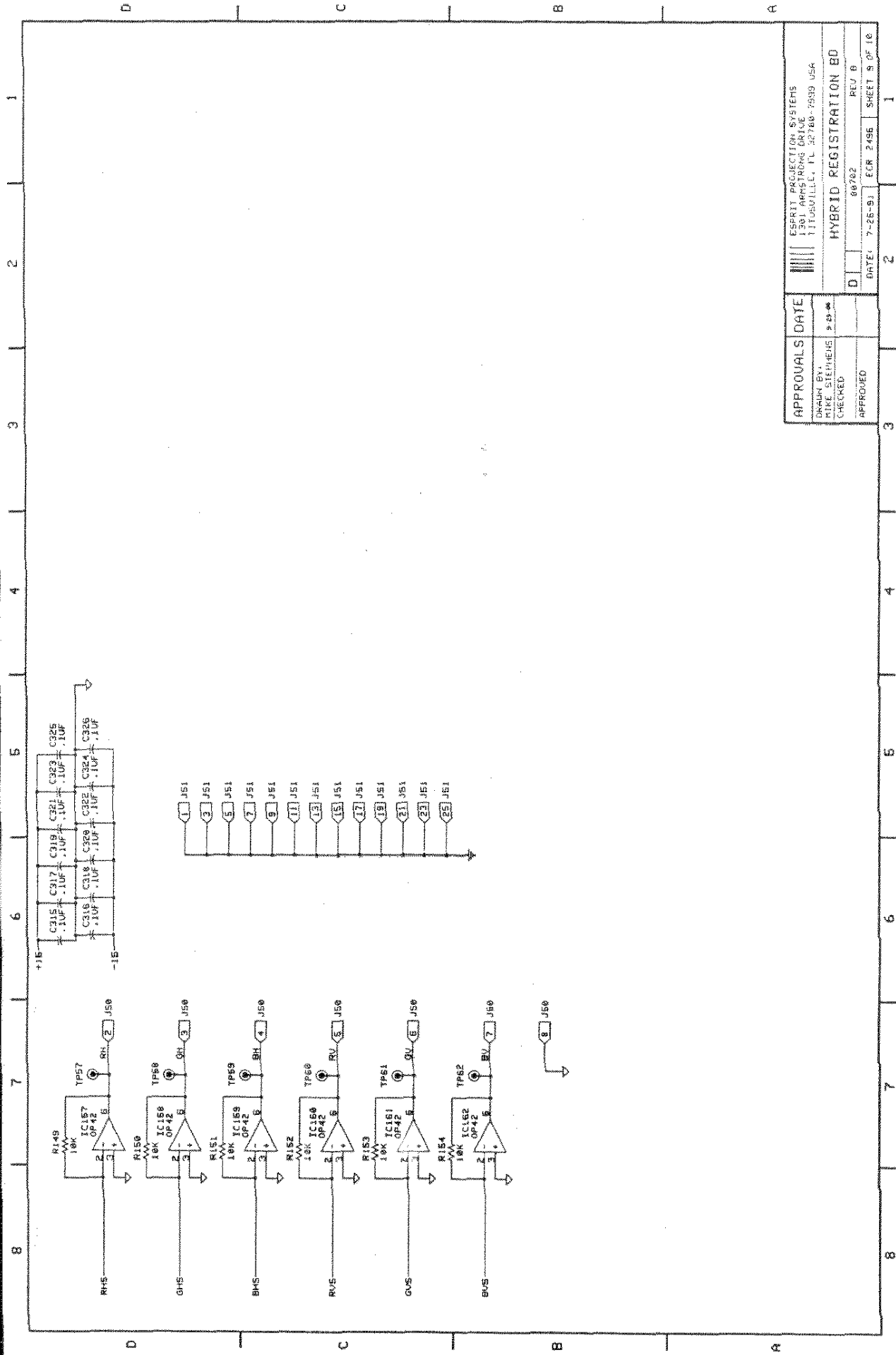

APPROVALS	DATE	 ESPRIT PROJECTION SYSTEMS 1301 ARMSTRONG DRIVE TITUSVILLE, FL 32780-7899 USA	HYBRID REGISTRATION BO 80702	REV. B
CHECKED	9-23-94			
APPROVED		DATE: 7-26-93	ECR: 2496	SHEET 9 OF 16

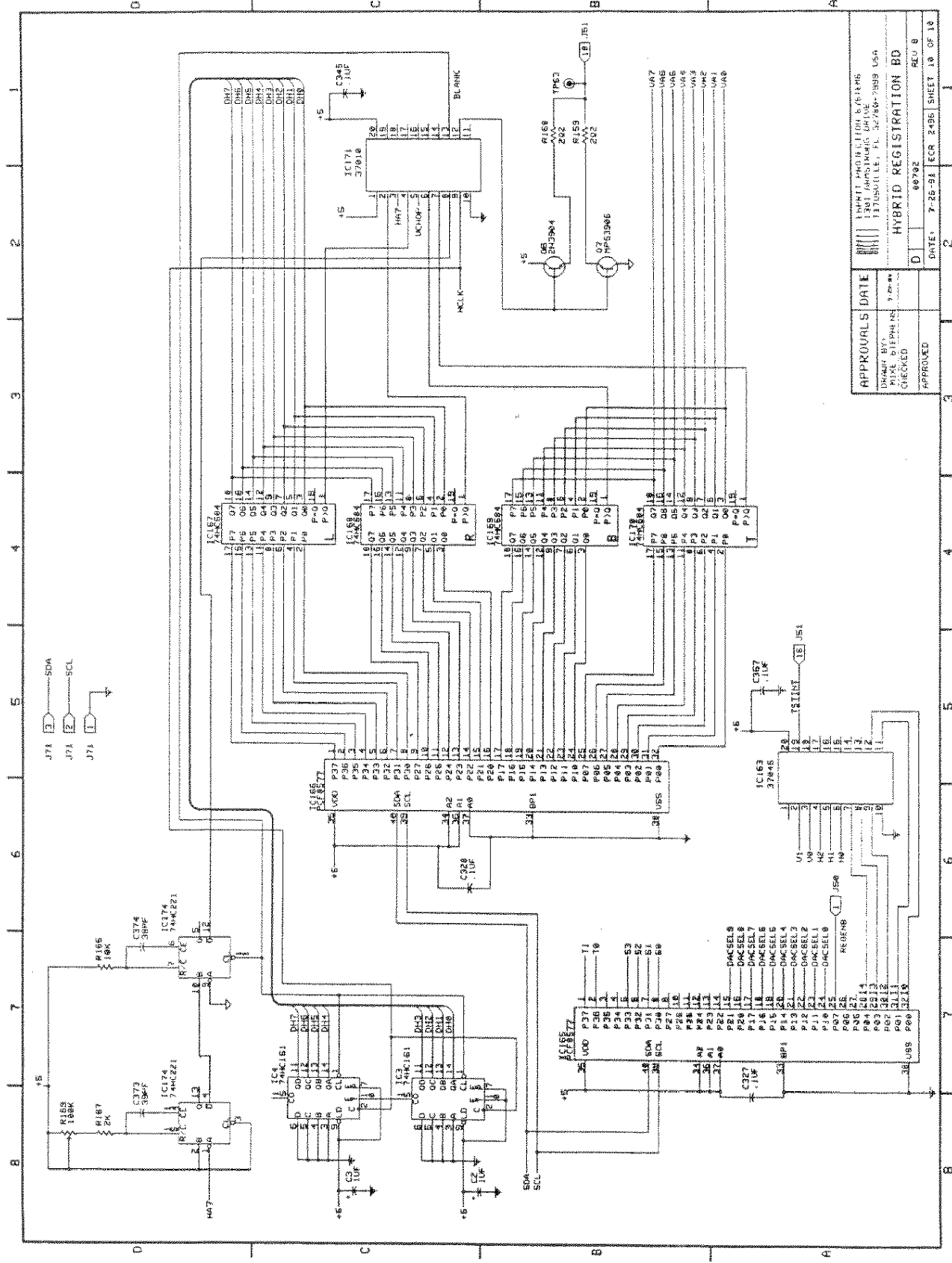

APPROVALS DATE	1991 MAR 21 10:45 AM
DESIGNED BY	MIKE BISHOP
CHECKED	
APPROVED	
DATE	7-25-91
ECR	2496
SHEET	10 OF 18

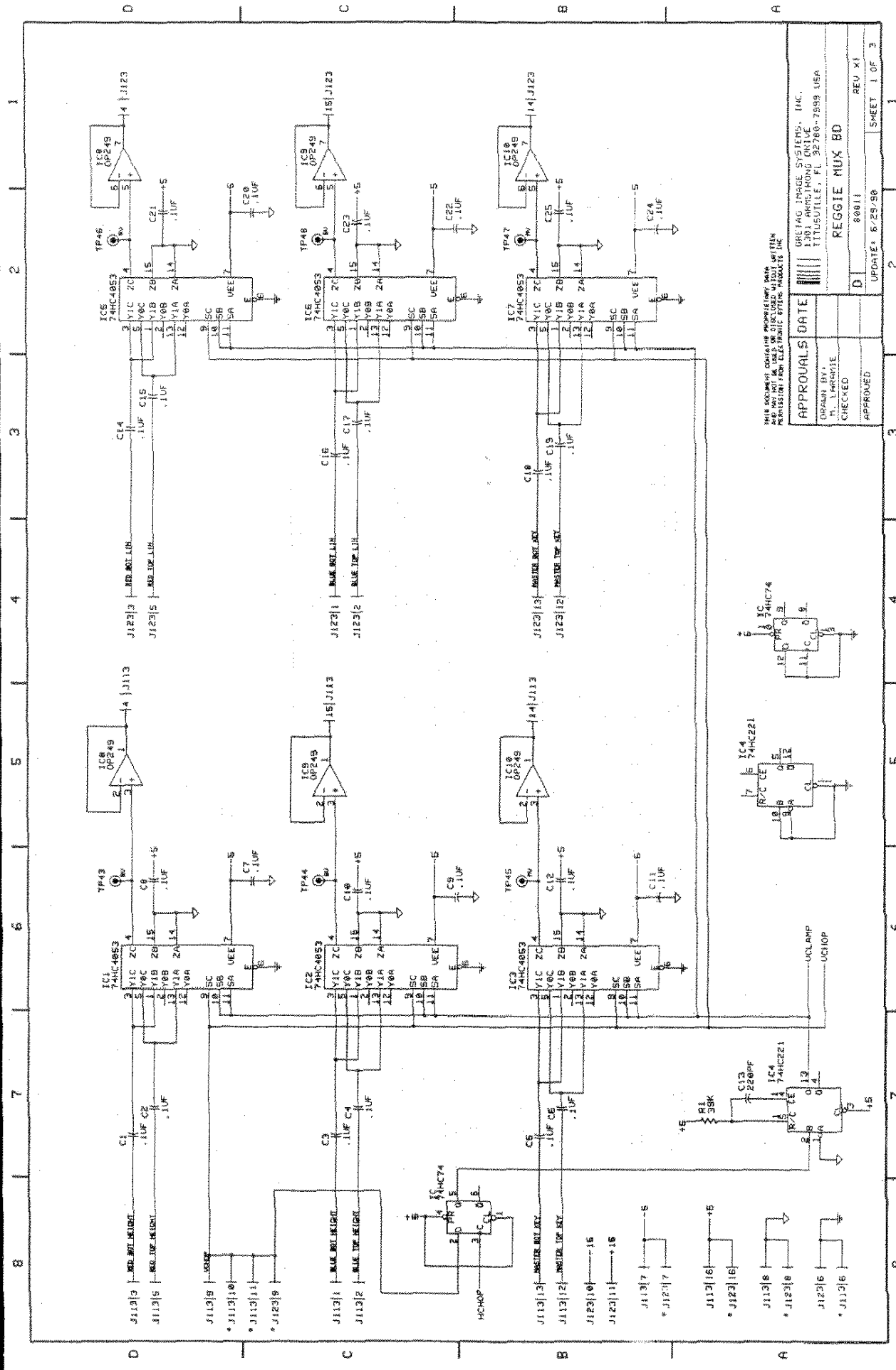

THIS DOCUMENT CONTAINS PROPRIETARY DATA
 AND MAY NOT BE DISCLOSED WITHOUT WRITTEN
 PERMISSION FROM ELECTRONIC SYSTEMS, INC.

APPROVALS DATE

DRAWN BY: T. L. LARMANIE
 CHECKED: _____
 APPROVED: _____

REGGIE MUX BD
 80811
 UPDATE: 6/29/98
 SHEET 1 OF 3

REGISTRATION MUX BOARD (80811X) SCHEMATIC 1 of 3

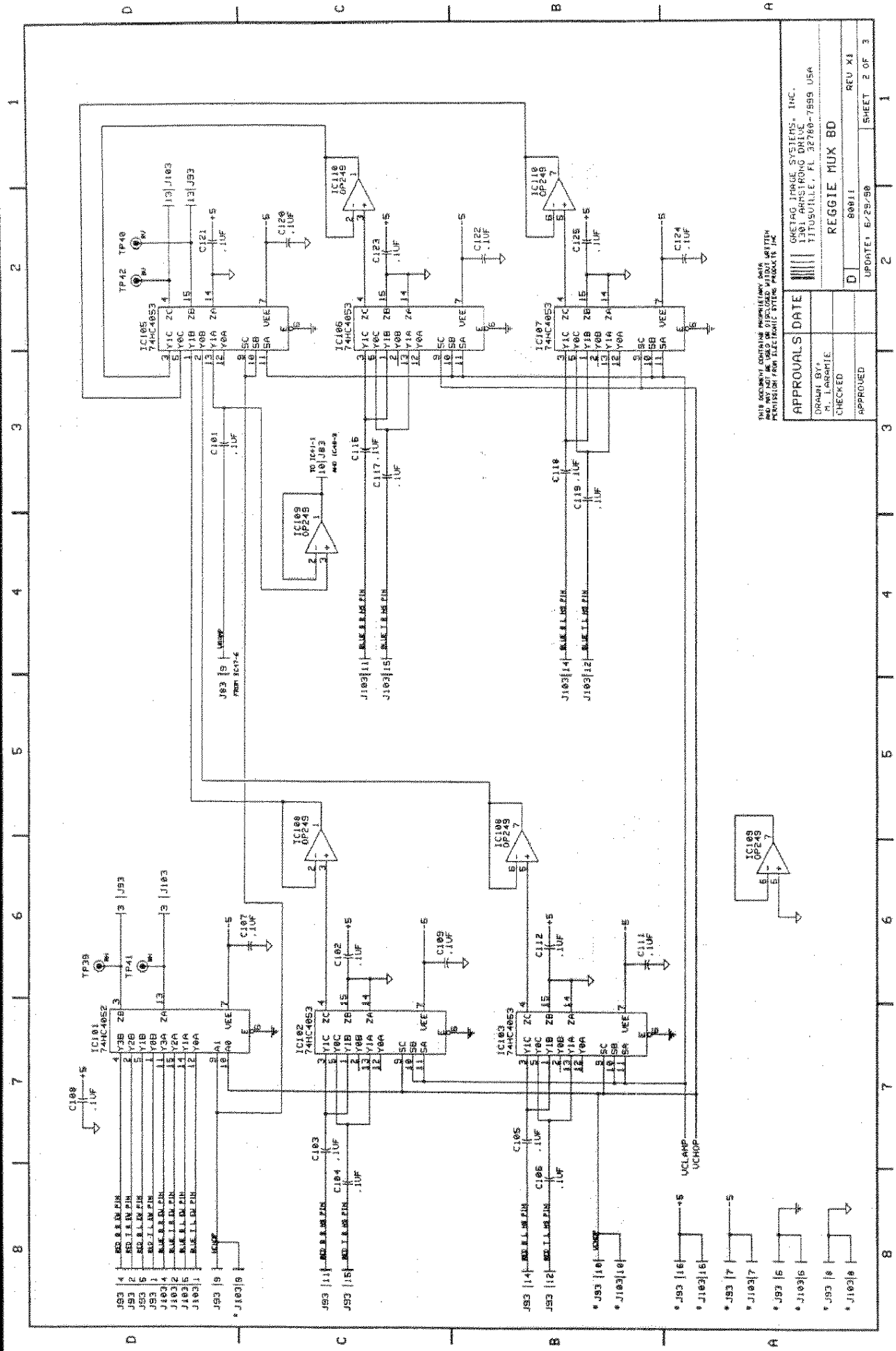

THIS DRAWING CONTAINS PROPRIETARY DATA
AND MAY NOT BE COPIED OR DISCLOSED WITHOUT WRITTEN
PERMISSION FROM ELECTRONIC SYSTEMS PRODUCTS, INC.

APPROVALS	DATE	REGGIE MUX BD
DRAWN BY:		80811
CHECKED:		REV. X1
APPROVED:		SHEET 2 OF 3

GACTAG JARGUE SYSTEMS, INC.
1301 PARKSTRONG DRIVE
TITUSVILLE, FL 32780-7999 USA

REGISTRATION MUX BOARD (80811X) SCHEMATIC 2 of 3

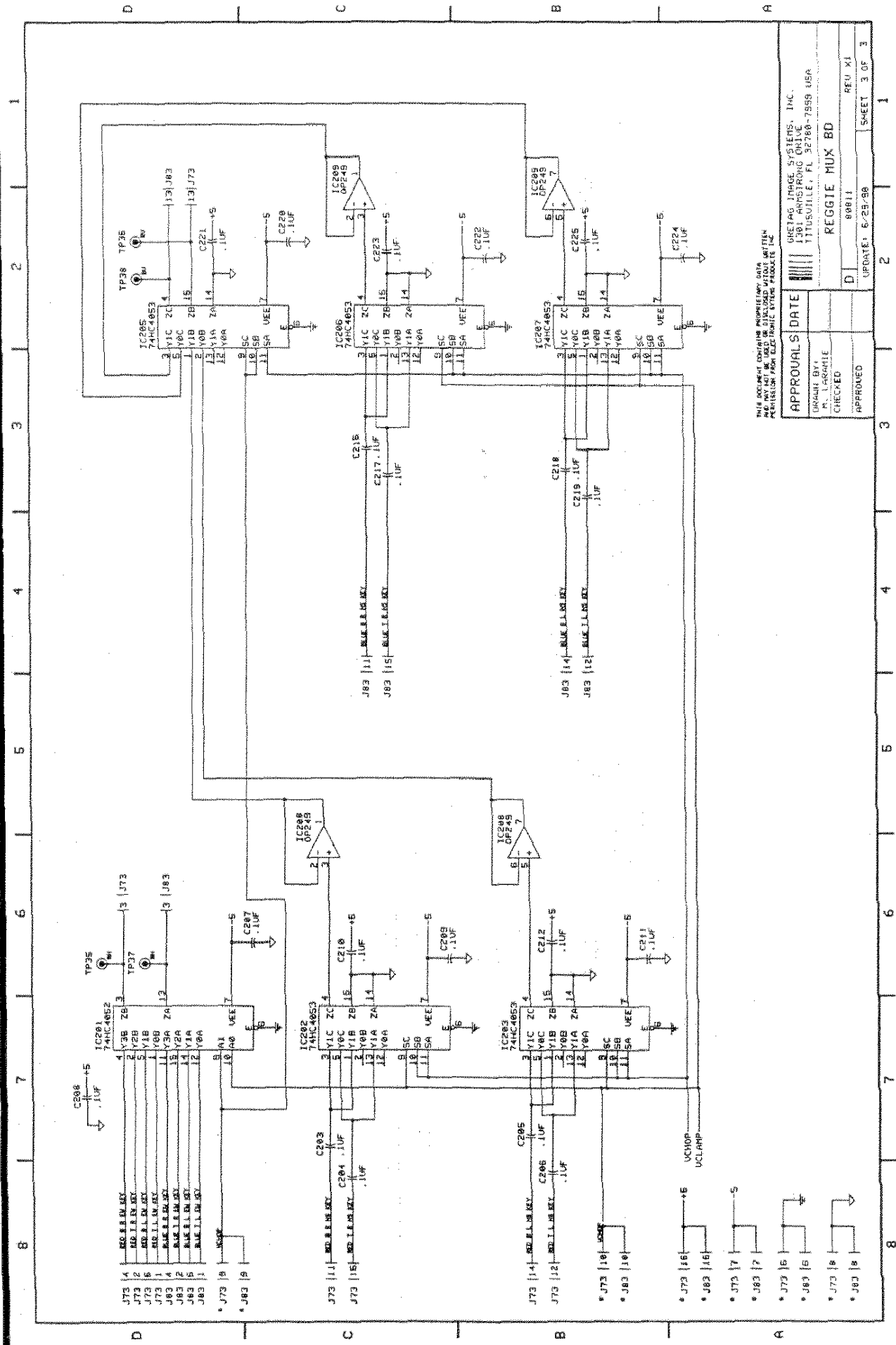

THIS DOCUMENT CONTAINS PROPRIETARY DATA AND MAY NOT BE USED OR DISCLOSED WITHOUT WRITTEN PERMISSION FROM ELECTRONIC SYSTEMS PRODUCTS, INC.

APPROVALS	DATE
DESIGNED BY	
CHECKED	
APPROVED	
REGGIE MUX BD	
80811	
UPDATE: 6/25/98	
SHEET 3 OF 3	

ESRTECS IMAGE SYSTEMS, INC.
1301 AMSTRONG DRIVE
TITUSVILLE, FL 32780-7899 USA

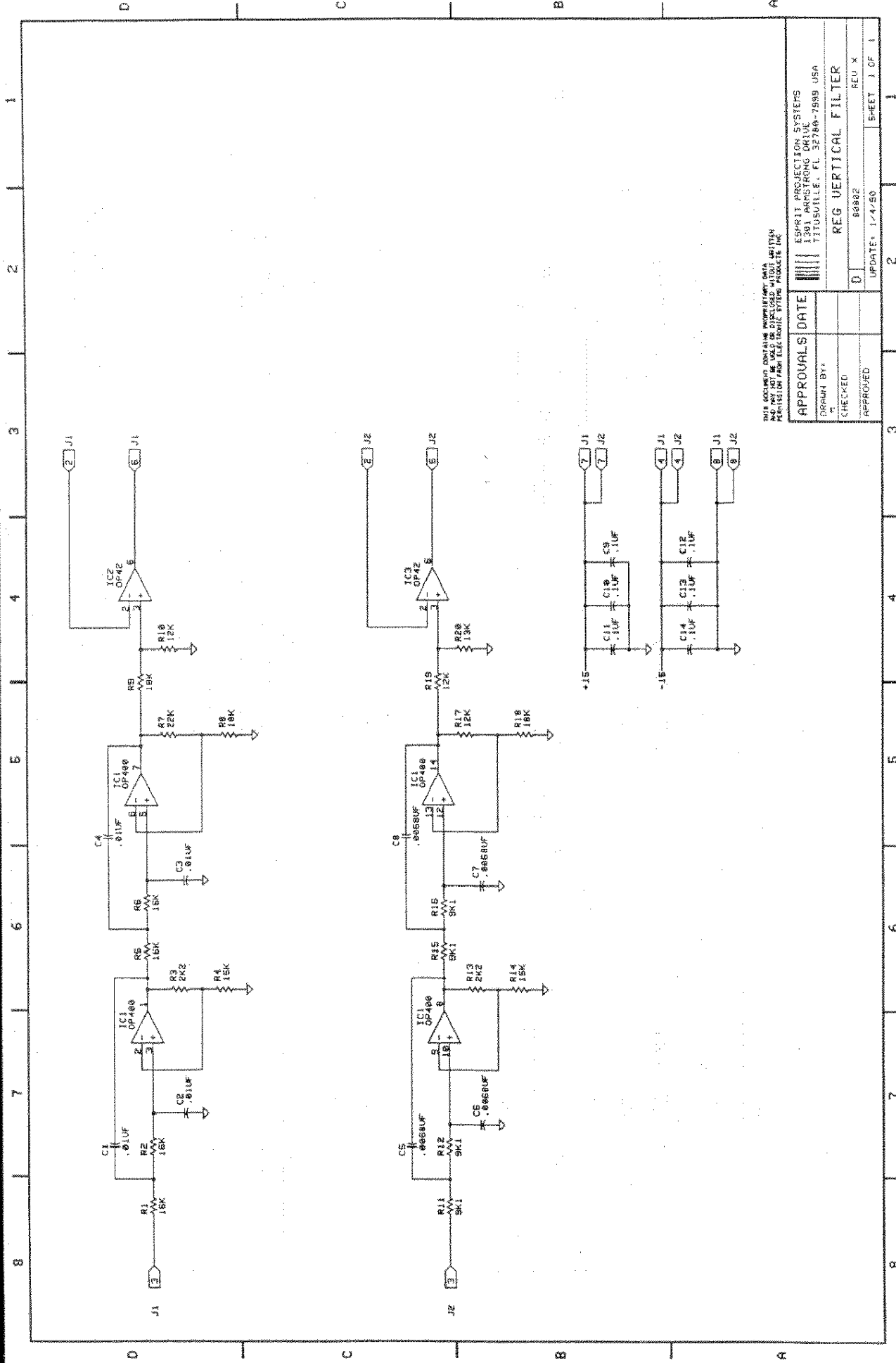

THIS DOCUMENT CONTAINS PROPRIETARY DATA
 AND MAY NOT BE USED OR DISCLOSED WITHOUT WRITTEN
 PERMISSION FROM ELECTRONIC SYSTEMS PRODUCTS, INC.

APPROVALS DATE	
DRAWN BY:	
CHECKED	
APPROVED	
REV X	
80802	
UPDATE: 1/4/90	
SHEET 1 OF 1	

ESPRIT PROJECTION SYSTEMS
 1381 ARMSTRONG DRIVE
 TITUSVILLE, FL 32780-7999 USA

REGISTRATION VERTICAL FILTER BOARD (80802X) SCHEMATIC 1 of 1

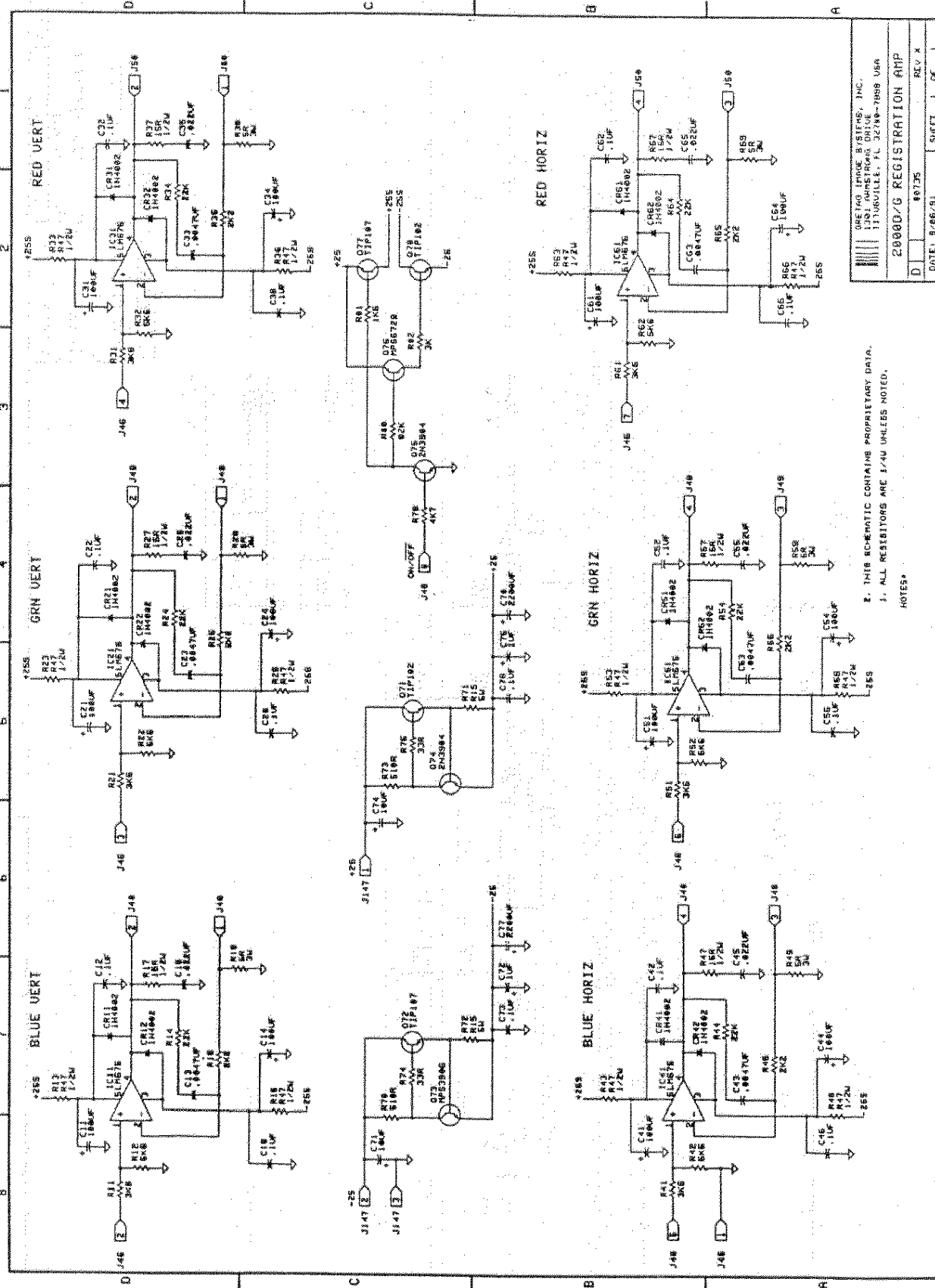

GREGG ENGINE SYSTEMS, INC.
 11700 BELLEVILLE, IL 62218-7008 USA
2000D/G REGISTRATION AMP
 DATE: 9/86/91 SHEET 1 OF 1

2. THIS SCHEMATIC CONTAINS PROPRIETARY DATA.
 3. ALL RESISTORS ARE 1/4W UNLESS NOTED.
 NOTES:

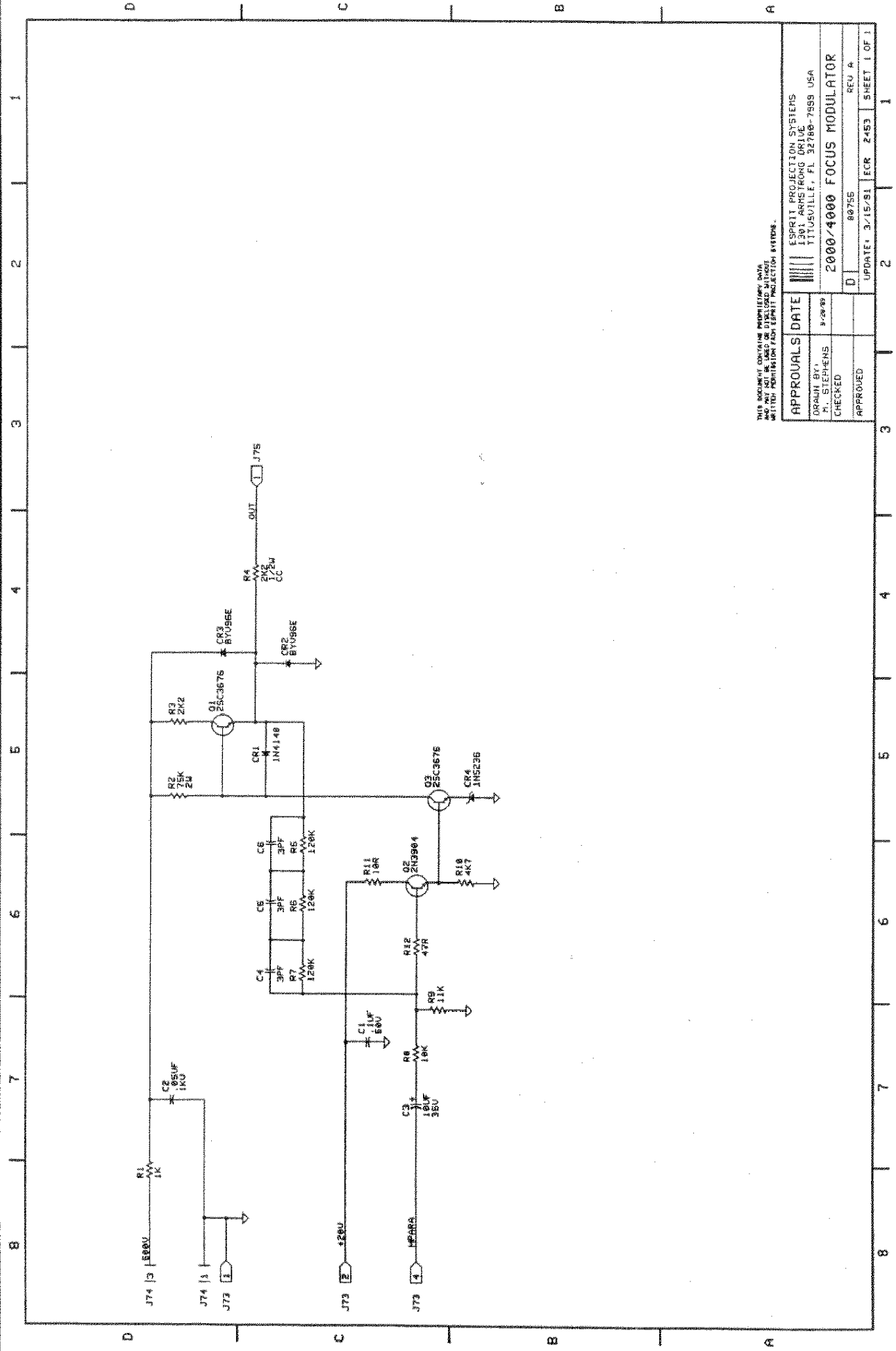

THIS DOCUMENT CONTAINS PROPRIETARY DATA AND MAY NOT BE USED OR DISCLOSED WITHOUT THE WRITTEN PERMISSION FROM ESPRIT PROJECTION SYSTEMS.

APPROVALS DATE	
DESIGNED BY	9/20/99
CHECKED	M. STEPHENS
APPROVED	
ESPRIT PROJECTION SYSTEMS 1301 ARMSTRONG DRIVE TITUSVILLE, FL 32780-7559 USA	
2000/4000 FOCUS MODULATOR	
D	80755
UPDATE: 3/15/01	ECR 2453
SHEET 1 OF 1	

FOCUS MODULATOR (80755A) SCHEMATIC 1 of 1

SECTION 3

MODULE AND CRT REPLACEMENT PROCEDURES

CPU	3-1
QUAD VIDEO DECODER	3-3
QUAD VIDEO DECODER FIELD INSTALLATION SUPPLEMENT	3-5
<i>set with scope</i> ANALOG RGB1	3-7
TTL/VGA	3-11
TTL/VGA FIELD INSTALLATION SUPPLEMENT	3-13
ANALOG RGB2	3-15
ANALOG RGB2 FIELD INSTALLATION SUPPLEMENT	3-17
TEST/TEXT INTERFACE	3-19
CRT AMPLIFIER CARD	3-21
VERTICAL DEFLECTION	3-23
HORIZONTAL DEFLECTION	3-25
H.O.T.	3-27
SWITCH MODE POWER SUPPLY	3-29
REGISTRATION BOARD	3-31
REGISTRATION AMPLIFIER	3-33
HIGH VOLTAGE POWER SUPPLY	3-35
7 INCH CRT	3-37
7 INCH CRT ASSEMBLY EXPLODED PARTS VIEW	3-40
LENS/BRACKET EXPLODED PARTS VIEW	3-41
7 INCH PIVOTING HEAD ASSEMBLY EXPLODED PARTS VIEW	3-42



CPU MODULE (80857) REPLACEMENT PROCEDURE

TOOLS REQUIRED



SMALL SLOTTED AND PHILLIPS SCREWDRIVER

REPLACEMENT PROCEDURE

CAUTION

CPU MODULE HANDLING IS CRITICAL. DO NOT PLACE THE SOLDER SIDE OR FOIL SIDE OF THIS MODULE ON ANY CONDUCTIVE MATERIAL, AS THIS WILL DAMAGE THE MODULE. OBSERVE NORMAL STATIC SENSITIVE HANDLING PROCEDURES.

- STEP 1. Disconnect the main A.C. power cord, and remove the top cover assembly.
- STEP 2. Disconnect all connections to the "HOST" or "SLAVE" ports of the CPU module.
- STEP 3. Unlock and tilt up the Registration board.
- STEP 4. Remove the two 4-40 phillips screws mounting the CPU module to the rear panel. Refer to Figure 3-1.
- STEP 5. Remove the single phillips screw securing the CPU module to the left side (as viewed from the rear) of the main chassis. Refer to Figure 3-1. NOTE: If not hinged, remove the left rear top cover mounting bracket.
- STEP 6. Carefully remove the CPU module from the main chassis.
- STEP 7. Install the replacement CPU and secure with the hardware previously removed and perform Steps 1 through 3 in reverse order.

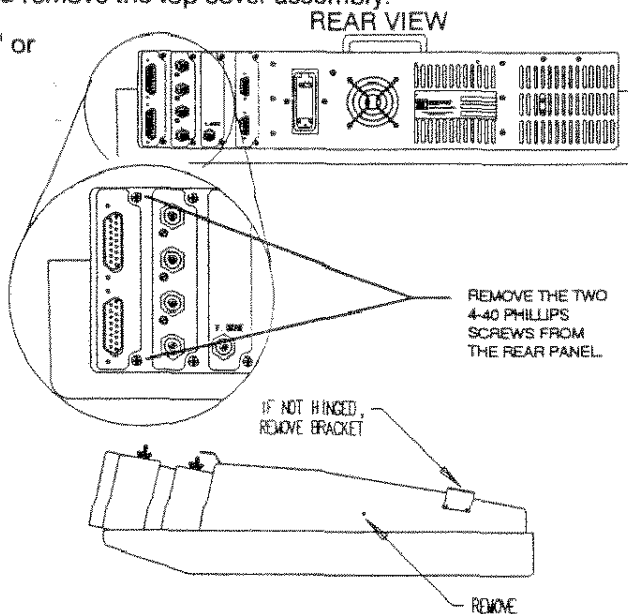

FIGURE 3-1. CPU MODULE REMOVAL/REPLACEMENT.

● NOTE 1: It may be necessary to setup all channels previously used.

● NOTE 2: Ensure that the address switches (S1/S2), baud rate switch (S3) and Dip switches (SW4) are in the proper configuration for your particular applications. See Figure 3-2

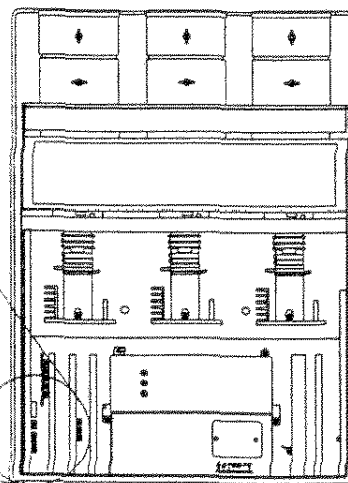
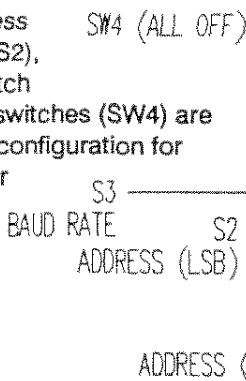

FIGURE 3-2.

ADDRESS, BAUD RATE AND DIP SWITCH 4 LOCATION.

NOTES:

QUAD VIDEO DECODER (80779) REPLACEMENT PROCEDURE

TOOLS REQUIRED



SLOTTED
SCREWDRIVER



SMALL
PHILLIPS
SCREWDRIVER

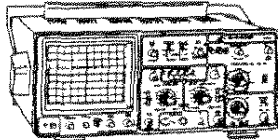

120MHz DUAL TRACE OSCILLOSCOPE
W/PROBES



NTSC COLOR BAR VIDEO
GENERATOR



AN ESPRIT
EXTENDER CARD
AmPro P/N 80738

REPLACEMENT PROCEDURE

- STEP 1. Disconnect the main A.C. power cord and remove the top cover assembly.
- STEP 2. Unlock and lift up the Registration board.
- STEP 3. Remove the two 4-40 phillips screws and lock washers securing the QVD¹ module to the rear panel. Third module from the left as viewed from the rear. See Figure 3-3.
- STEP 4. Lift the QVD module straight up and out of the main chassis.
- NOTE 1: DO NOT install the QVD module at this time. Please refer to the PRE-ADJUSTMENT REQUIREMENTS for further instructions.

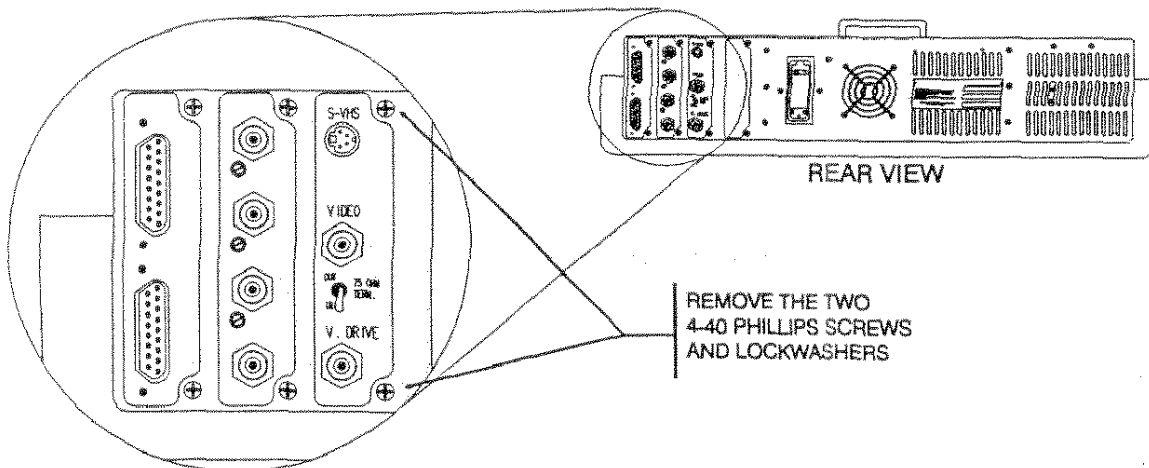

FIGURE 3-3. QUAD VIDEO DECODER MODULE REMOVAL

PRE-ADJUSTMENT REQUIREMENTS

- Input: 1vp-p color bars with IWQ, burst and chroma "off".
- Channel: any channel that has been setup for NTSC 3.58 video operation. (write-protect "off"-20 CODE).
- Remote settings: brightness 95%, contrast 95%
- Place the QVD module onto the ESPRIT extender card and then into the QVD module slot.
- On the QVD module, ensure the 75Ω termination switch is placed to the "IN" position.

QVD¹: QUAD VIDEO DECODER

ADJUSTMENT PROCEDURE

ENSURE THAT THE ANALOG RGB1 MODULE HAS BEEN ADJUSTED PROPERLY BEFORE CONTINUING WITH THIS PROCEDURE.

- STEP 1. Apply A.C. power and energize the system.
- STEP 2. With the oscilloscope, probe TP2 on the Green CRT Amplifier card
- STEP 3. Set Master Sub-brite (R111-foil side of the QVD module) to +170V above ground and Master Sub-contrast (R91) for peak white of +40V above ground.
- STEP 4. With the oscilloscope, probe TP2 on the RED CRT Amplifier card.
- STEP 5. Set Red Sub-brite (R86) for peak white of +40V above ground.
- STEP 6. Repeat STEP 5 for the Blue video signal by setting the Blue Sub-brite (R98) for peak white of +40V above ground.
- STEP 7. Select an "off-the-air" composite video signal and enable the monochrome mode of operation by entering (49-CODE).
- STEP 8. Optimize the gray scale as necessary by further adjustment of the Red Sub-brite (R86) and the Blue Sub-brite (R98).
- STEP 9. De-energize the system.
- STEP 10. Install the replacement QVD into the appropriate slot and secure with the hardware previously removed.
- STEP 11. Lower and lock the Registration board into place and replace the top cover assembly.

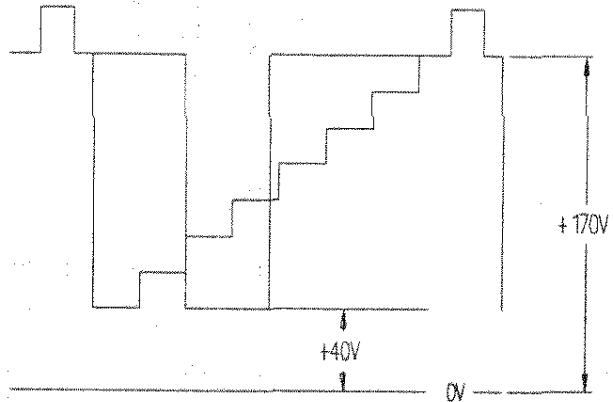

FIGURE 3-4.

Quad Video Decoder required video setup pattern.

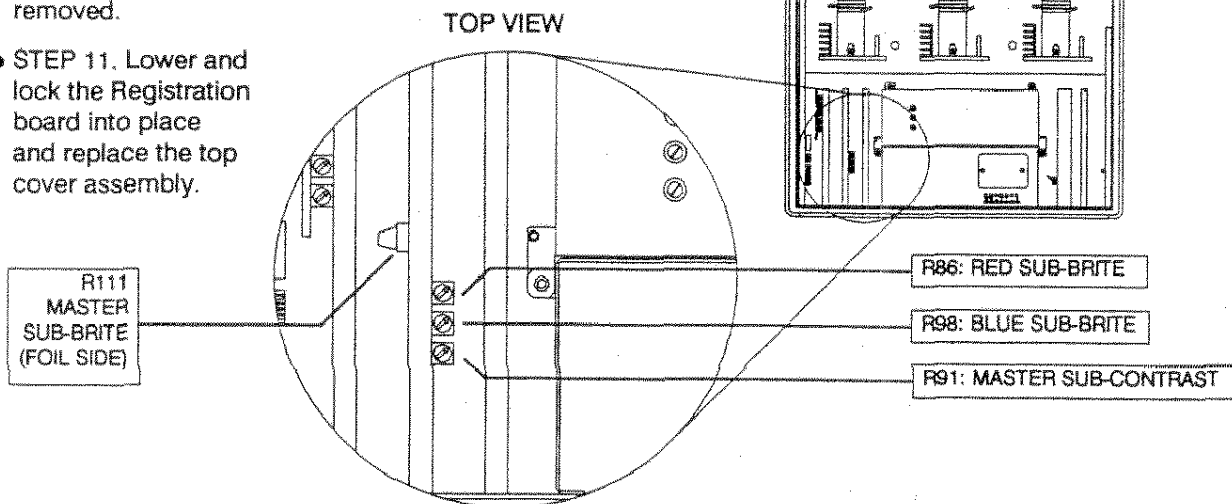

FIGURE 3-5. QUAD VIDEO DECODER ADJUSTMENTS.

QVD MODULE INSTALLATION PROCEDURE SUPPLEMENT

This section provides the necessary information for installing, as a new addition, the optional Quad Video Decoder module for the ESPRIT 2000 D/G Series Display Systems.

For the following installation procedure, the top cover must be removed and the registration board unlocked and tilted up.

INSTALLATION PROCEDURE

- STEP 1. De-energize the system and remove the main A.C. power cord.
- STEP 2. The QVD module is installed into the third slot from the left , as viewed from the rear.
- STEP 3. Remove the Vertical Sync panel from the third slot from the left by removing the two 4- 40 phillips screws/lock washers, disconnect J40 (2 pin plug) , and lift out the Vertical Sync panel.
- STEP 4. With this slot empty, insert the S-VHS/Quad Video Decoder module and secure with the two 4-40 phillips screws and lockwashers previously removed.
- STEP 5. Locate DIP switch SW4 on the CPU module. Change SW4-1 to the "ON" position, replace the power cord and energize the system. Refer to figure 3-6.

- STEP 6. Once the system has been initialized, use the numeric keypad and enter 72, then press the CODE button. The LCD will display:
QUAD DECODER INSTALLED
- STEP 7. Return SW4-1 (CPU module) to the "OFF" position and enter 44 then press the CODE button [READ SWITCHES].

- STEP 8. To verify your installation enter 34, then press the CODE button [DISPLAYS BOARD STATUS ON LCD].

● NOTE: Refer to the ADJUSTMENT PROCEDURE if required.

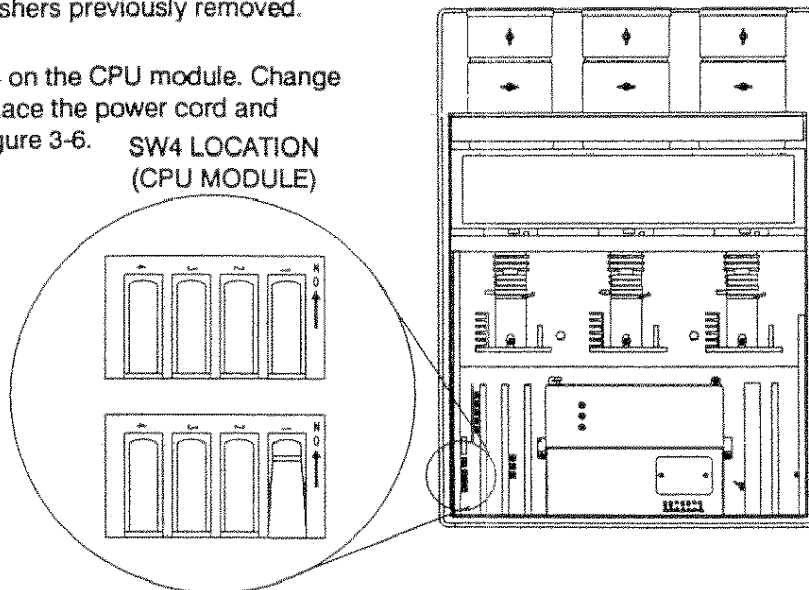

FIGURE 3-6. ADDING A QUAD VIDEO DECODER MODULE.
LOCATION OF DIP SWITCH SW4 (CPU MODULE)

ADDITIONAL CODES

- 73 CODE: CLEAR ALL MODULES
- 75 CODE: CLEAR QUAD MODULE.
- NOTE: Refer to your particular operation manual for the operation and selection of the Video Mode of operation.

NOTES

ANALOG RGB1 MODULE (80881) REPLACEMENT PROCEDURE

TOOLS/EQUIPMENT REQUIRED



SMALL
SLOTTED
AND
SMALL
PHILLIPS
SCREWDRIVER

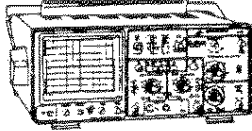

120MHz
DUAL TRACE
OSCILLOSCOPE
W/PROBES



NTSC COLOR
BAR VIDEO
GENERATOR
W/TWO

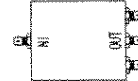

1 1/4" x 3" OUT
VIDEO
DISTRIBUTION
AMPLIFIER

REPLACEMENT PROCEDURE

- STEP 1. Disconnect the main A.C. power cord and remove the top cover assembly.
- STEP 2. Unlock and lift up the Registration board.
- STEP 3. If required, remove the top cover's left rear mounting bracket.
- STEP 4. On the RGB1 module (second module from the left as view from the rear) remove the three berg connectors (coax cables) located at the lens end of this module. Refer to Figure 3-7, Detail A.
- STEP 5. Remove the two 4-40 phillips screws securing the RGB1 module to the rear panel. Refer to Figure 3-7, Detail B.
- STEP 6. Lift the RGB1 straight up and out of the main chassis.
- STEP 7. Install the replacement RGB1 module and secure with the two 4-40 phillips screws.
- STEP 8. Replace the three coax cable from the Red, Green and Blue CRT Amplifier cards to their respective connectors on the RGB1 Module. Refer to Figure 3-7, Detail C. NOTE: Notch points up.

DETAIL A

RGB1 TO CRT AMPLIFIER
CARD CONNECTORS (3 EA.)

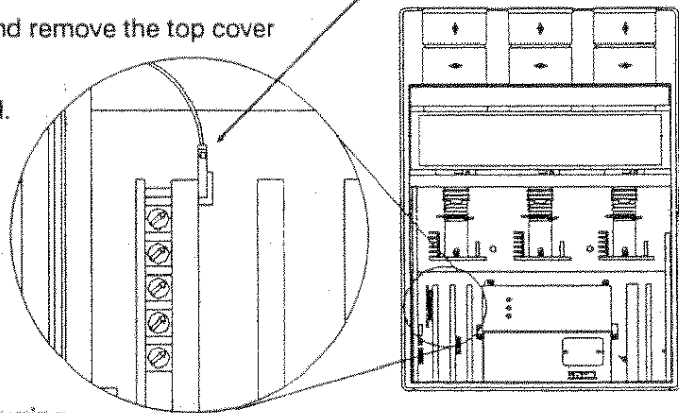

DETAIL B

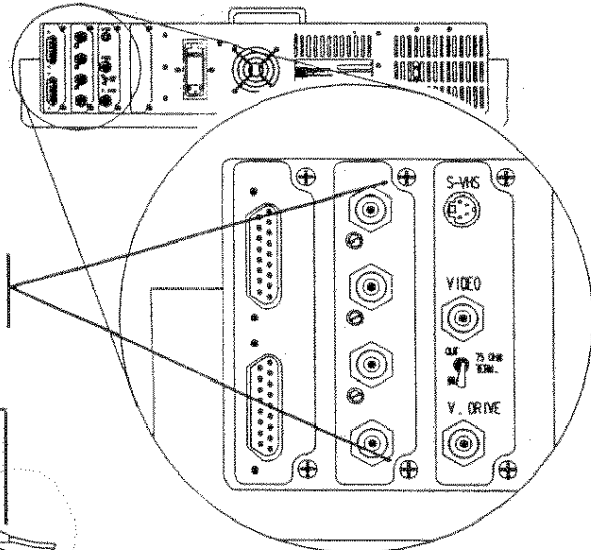

REMOVE THE TWO
4-40 PHILLIPS
SCREWS AND
LOCK WASHERS

DETAIL C

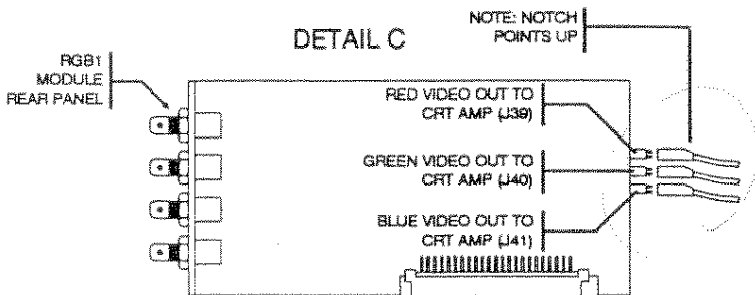

*if reversed
it won't give video.
(note labeling)*

FIGURE 3-7. ANALOG RGB1 REMOVAL/REPLACEMENT.

PRE-ADJUSTMENT REQUIREMENTS

- Input: 1vp-p color bars w/IWO, burst and chroma off...into a 1 "IN" 3 "OUT" DA, and connected to the Red, Green and Blue inputs located on the RGB1 module.
- Clamping: select back porch clamping (48 CODE).
- Channel: any channel setup for 15kHz, RGB mode of operation (write protect "OFF"-20 CODE).
- Remote settings: Brightness 95%, Contrast 95%
- Board settings: set Red, Green and Blue Gain Controls on rear of RGB1 module to max (clockwise). See Figure 3-9.

ADJUSTMENT PROCEDURE

- STEP 1: Set CRT Cutoffs
 - A.) Using the Remote Control, cutoff all three CRT's
 - B.) Adjust each CRT (R26-G2 control, on each CRT Amplifier card) so that there is no color on each raster as viewed from the lens. then restore CRT cutoffs. Refer to Appendix A for further information.
- STEP 2. Setup grayscale for the RGB1 operation. Refer to Figure 3-8 and 3-9 as required.
 - A.) GREEN VIDEO: with the O'scope probe TP2 (backside of Green CRT Amp Board), set Green sub-brite (R179-black level) to +170v above ground and master contrast (R187) for peak white of +40v above ground.
 - B.) RED VIDEO: with the O'scope probe TP2 (backside of Red CRT Amp Card), set Red sub-brite (R172-black level) to +170v above ground. if peak white is less than +40v above ground, reduce master contrast (R187) to obtain +40v above ground.
 - C.) Repeat above step for BLUE VIDEO signal by setting blue sub- brite (R191-black level) to +170v above ground and adjusting master contrast (R187) as necessary to obtain a peak white level of +40v above ground.
 - D.) If the master contrast (R187) has been adjusted during the above procedure, reduce the respective gain control on the rear of the RGB1 panel to achieve a sub-brite level of +170v above ground and a peak white level of +40v above ground for each color.
 - E.) As required, readjust the Remote Control brightness and contrast for each channel being used.
- STEP 3. Connect your external source and readjust the rear panel gain controls to achieve a proper color balance of your displayed image. Refer to Figure 3-9.

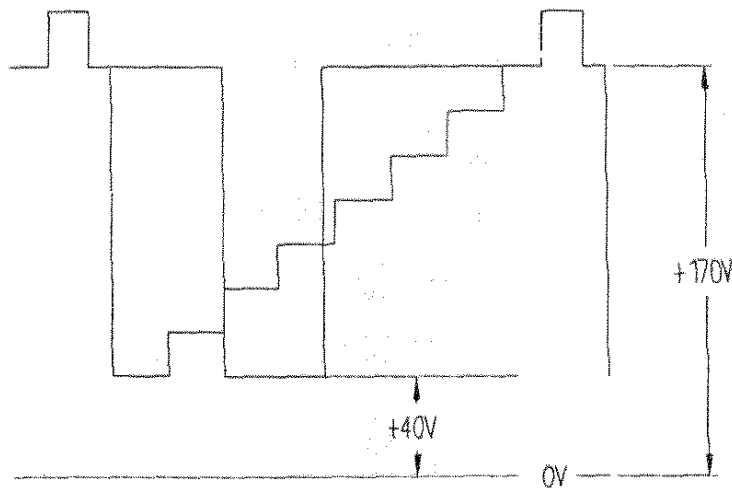

FIGURE 3-8. GRAYSCALE SETUP PATTERN (STAIRSTEP).

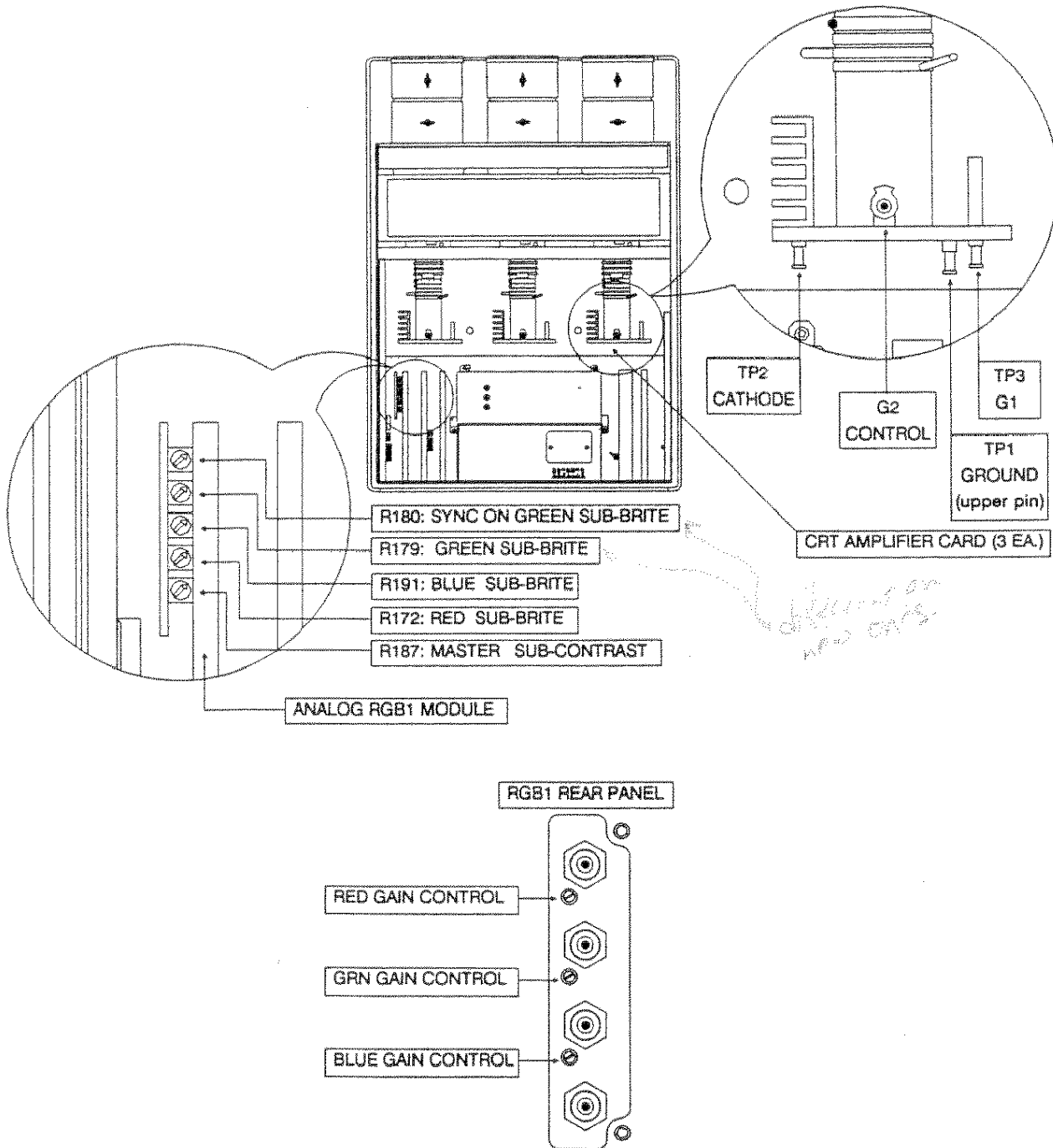

FIGURE 3-9. RGB, CRT CARD LAYOUT AND DESCRIPTION.

NOTES:

TTL/VGA MODULE (80715) REPLACEMENT PROCEDURE

TOOLS REQUIRED



SMALL
PHILLIPS
SCREWDRIVER



SMALL
SLOTTED
ALIGNMENT
TOOL

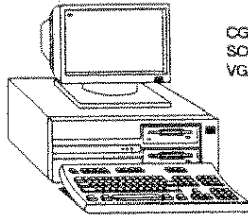

CGA OR EGA
SOURCE AND
VGA SOURCE

REPLACEMENT PROCEDURE

- STEP 1. De-energize the system, remove the A.C. power cord and top cover assembly.
- STEP 2. Unlock and tilt up the Registration board.
- STEP 3. Remove the two 4-40 phillips screws and lock washers securing the TTL module (fourth module from the left as view from the rear), to the rear panel. See Figure 3-10.
- STEP 4. Lift the TTL module straight up and out of the main chassis assembly.
- STEP 5. Install the replacement TTL module into the fourth slot and secure with the hardware previously removed.
- STEP 6. Lower and lock the Registration board into place.

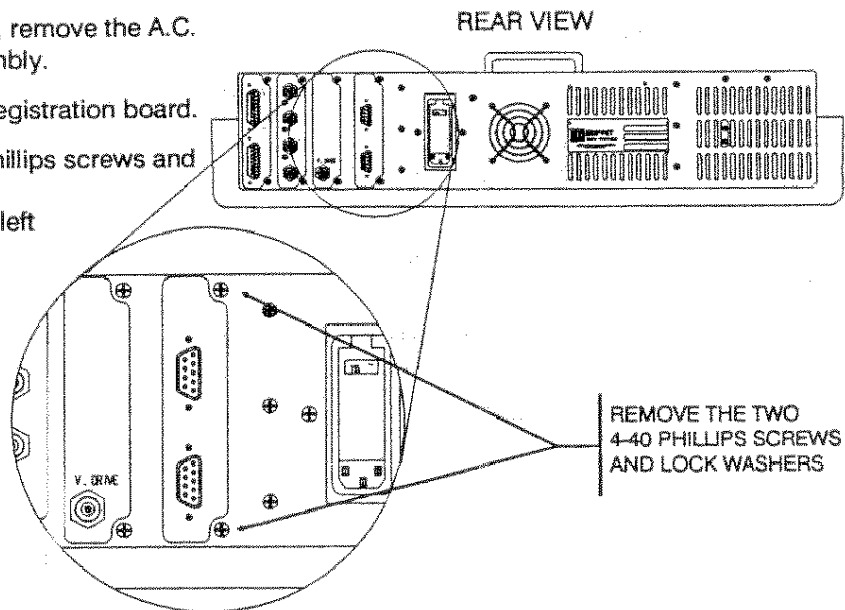

FIGURE 3-10. TTL MODULE REMOVAL

PRE-ADJUSTMENTS REQUIREMENTS

- Input: CGA or EGA gray scale pattern and a VGA gray scale pattern.
- Channel: any one channel setup for CGA/EGA mode of operation, and a channel setup for the VGA mode of operation.
- Remote settings: brightness 100% and contrast 85%.

ADJUSTMENT PROCEDURE

ENSURE THE ANALOG RGB1 MODULE HAS BEEN PROPERLY ADJUSTED BEFORE CONTINUING WITH THIS PROCEDURE.

CGA/EGA ADJUSTMENT

- STEP 1. Connect the A.C. power cord and energize the system.
- STEP 2. Select a channel that is setup for the CGA/EGA mode of operation.
- STEP 3. On the TTL module, adjust Red sub-contrast (R6), Green sub-contrast (R11) and/or Blue sub-contrast (R16) to obtain an optimum gray scale. Refer to Figure 3-11

VGA ADJUSTMENT

- STEP 1. Select a channel setup for the VGA mode of operation.
- STEP 2. On the TTL module, adjust Red sub-contrast (R35), Green sub-contrast (R48), and/or Blue sub-contrast (R41) to obtain the proper gray scale.
- NOTE: The CGA/EGA adjustments must be made first. These adjustments will affect the setting of the VGA controls. Refer to Figure 3-11
- NOTE: Upon completion of the above setup, perform Step 1 through 3 in reverse order.

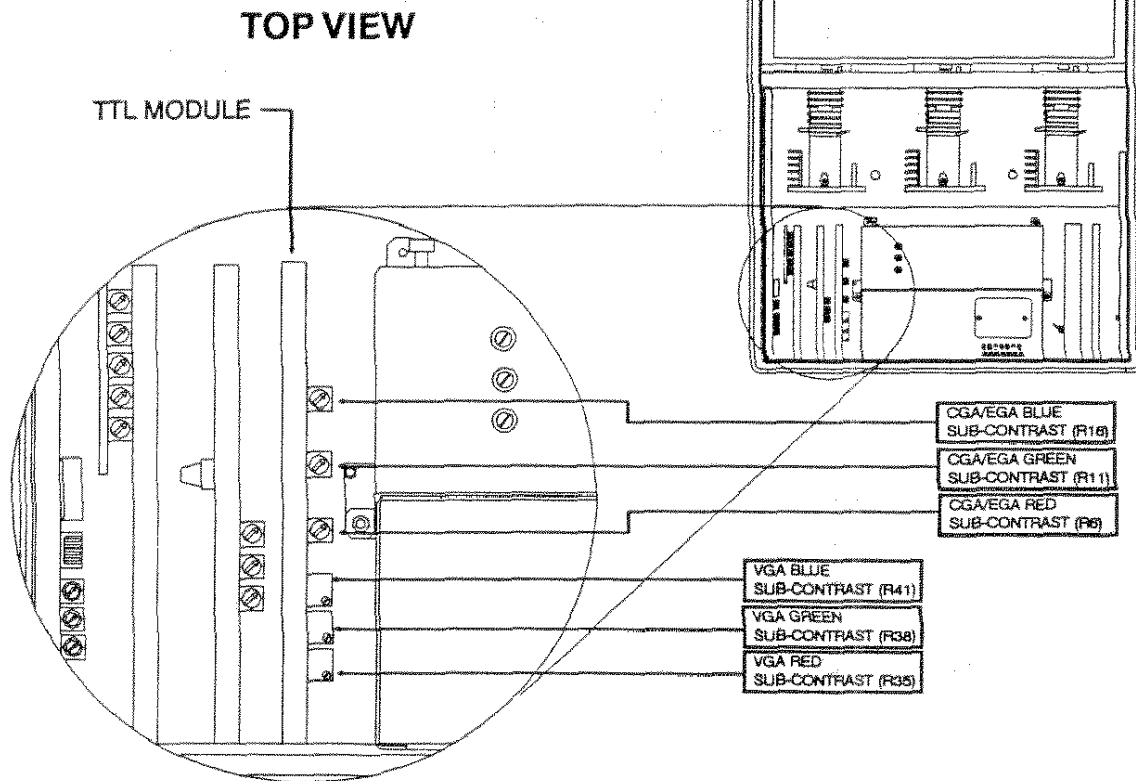

FIGURE 3-11. CGA/EGA AND VGA CONTRAST CONTROLS.

TTL/VGA MODULE INSTALLATION PROCEDURE SUPPLEMENT

This section provides the necessary information for installing, as a new addition the optional TTL/VGA module for the ESPRIT 2000 D/G Series Display Systems.

For the following installation procedure, the top cover must be removed and the registration board unlocked and tilted up.

INSTALLATION PROCEDURE

- STEP 1. De-energize the system and remove the main power cord.
- STEP 2. The TTL/VGA module is installed into the fourth slot from the left, as view from the rear.
- STEP 3. If the Analog RGB2 module has been previously installed or the TEST/TEXT module is located in the fourth slot, remove the two 4-40 phillips screws, lock washers, and lift-out the respective module.
- STEP 4. Install the TTL/VGA module and secure with the two 4-40 phillips screws and lock washers.
- STEP 5. Locate the DIP switch SW4 on the CPU module.
Change SW4-1 to the "ON" position, replace the power cord and energize the system. Refer to figure 3-12.
- STEP 6. Once the system has been energized, use the numeric keypad and enter 71, then press the CODE button. The LCD read-out will display:
[TTL INSTALLED].
- STEP 7. Return SW4-1 (CPU module) to the "OFF" position and enter 44 then press the CODE button :
[READ SWITCHES].
- STEP 8. To verify your installation enter 34, then press the CODE button:
[DISPLAYS BOARD STATUS ON LCD].

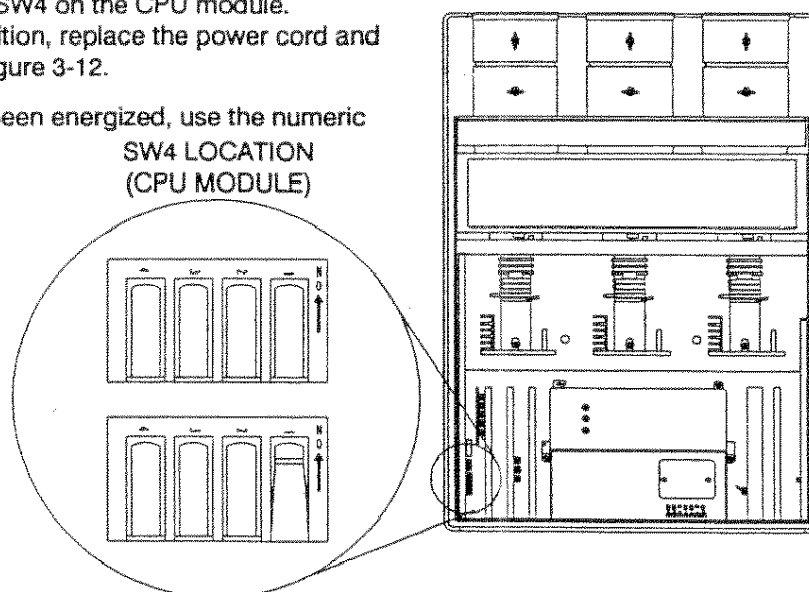

FIGURE 3-12. ADDING A TTL/VGA MODULE.

ADDITIONAL CODES

- 73 CODE: CLEAR ALL MODULES
- 74 CODE: CLEAR TTL MODULE
- NOTE: Refer to your operation manual for the operation and selection of the TTL/VGA mode of operation.

NOTES:

ANALOG RGB2 MODULE (80786) REPLACEMENT PROCEDURE

TOOLS/EQUIPMENT REQUIRED

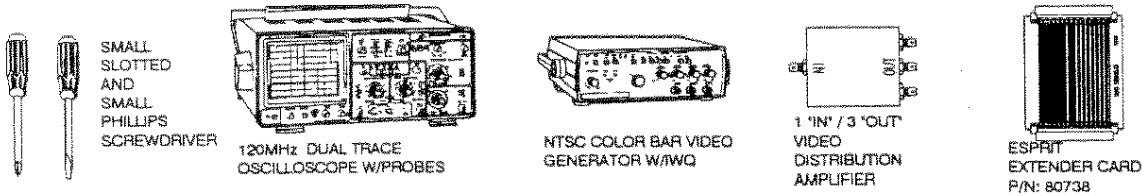

REPLACEMENT PROCEDURE

- STEP 1. De-energize the system and remove the main A.C. power cord.
- STEP 2. Remove the top cover assembly.
- STEP 3. Unlock and lift up the Registration board.
- STEP 4. Remove the two 4-40 phillips screws/lock washers securing the RGB2 module to the rear panel. Refer to Figure 3-13.
- STEP 5. Lift the RGB2 straight up and out of the main chassis.

- NOTE: Install the replacement RGB2 module onto an extender card, and then into the appropriate slot.

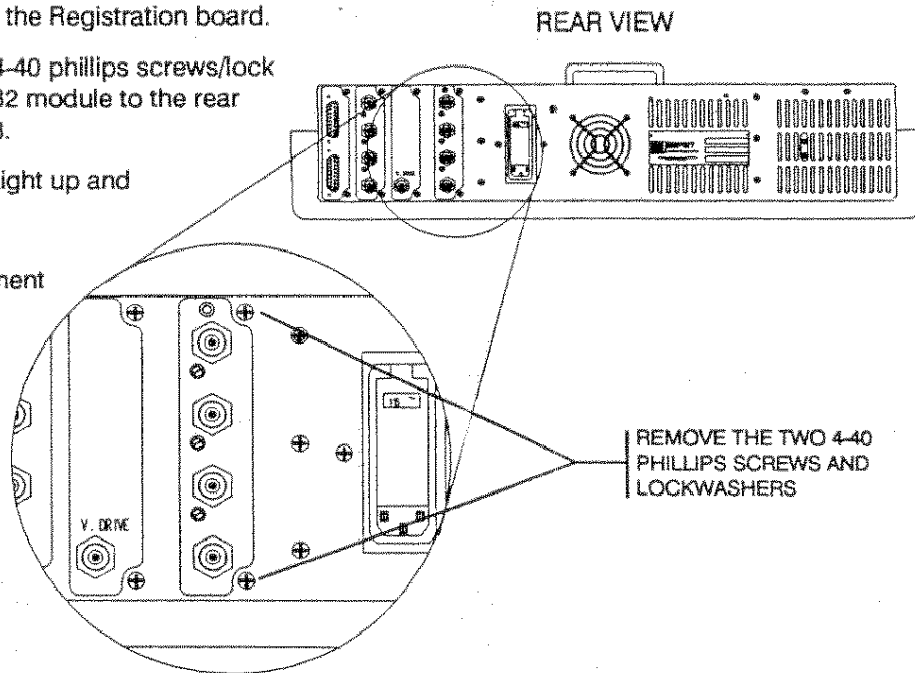

FIGURE 3-13. ANALOG RGB2 MODULE REPLACEMENT.

PRE-ADJUSTMENT REQUIREMENTS

- Input: 1vp-p color bars w/IWQ, burst and chroma off...into a 1 "IN" 3 "OUT" DA, and connected to the Red, Green and Blue inputs located on the RGB2 module.
- Clamping: select back porch clamping (48 CODE).
- Channel: any channel setup for 15kHz, RGB2 mode of operation (write protect "OFF"-20 CODE).
- Remote settings: Brightness 95%, Contrast 95%
- Board settings: set Red, Green and Blue Gain Controls on rear of RGB2 module to maximum (clockwise). See Figure 3-15.

ADJUSTMENT PROCEDURE

ENSURE THE ANALOG RGB1 MODULE HAS BEEN PROPERLY ADJUSTED BEFORE CONTINUING WITH THIS PROCEDURE.

- STEP 1. Setup grayscale for the RGB1 operation. Refer to Figure 3-14 and 3-15 as required.

A.) GREEN VIDEO: with the O'scope probe TP2 (backside of Green CRT Amp Board), set Green sub-contrast (R17) for peak white of +40v above ground.

B.) RED VIDEO: with the O'scope probe TP2 (backside of Red CRT Amp Card), set Red sub-contrast (R16) for peak white of +40v above ground.

C.) Repeat above step for BLUE VIDEO signal by setting Blue sub-contrast (R18) to obtain a peak white level of +40v above ground.

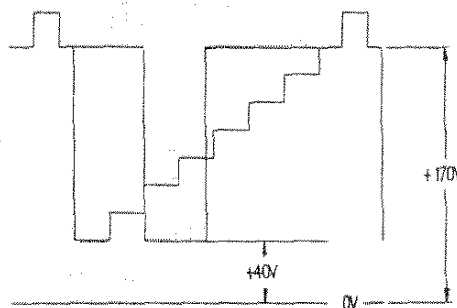
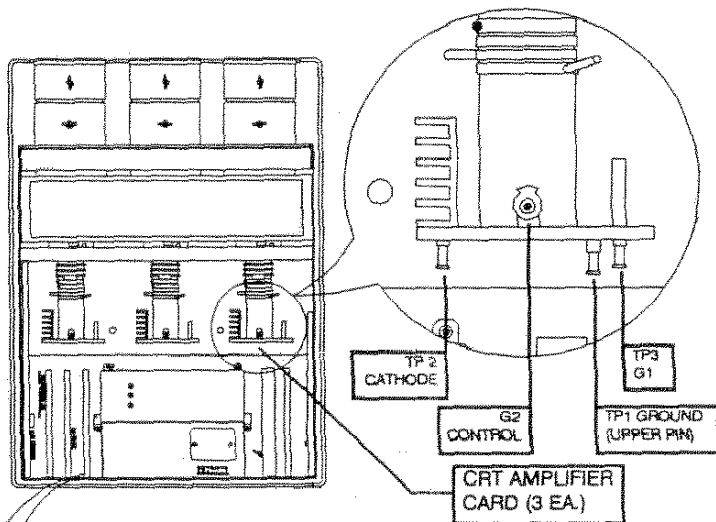

FIGURE 3-14. GRAY SCALE (STAIRSTEP) SETUP SIGNAL.

D.) Readjust the Red, Green and Blue sub-contrasts to obtain a visually acceptable grayscale.

E.) If necessary, readjust the Remote Control brightness and contrast for each RGB2 channel being used.

- STEP 2. De-energize the system and install the Analog RGB2 module in the appropriate slot and secure with the hardware previously removed.
- STEP 3. If required, readjust the rear panel gain controls to optimize your image.
- STEP 4. Lower and lock the Registration board into place and replace the top cover assembly.



RGB2 PANEL (REAR VIEW)

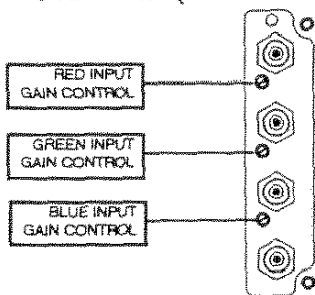

RGB2 MODULE (SIDE VIEW)

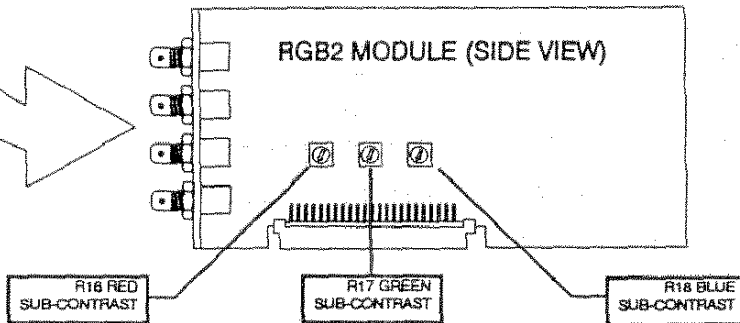

FIGURE 3-15.

ANALOG RGB2, CRT CARD LAYOUT AND DESCRIPTIONS

ANALOG RGB2 MODULE INSTALLATION SUPPLEMENT

This section provides the necessary information for installing, as a new addition, the optional Analog RGB2 module for the ESPRIT 2000 D/G Series Display Systems.

For the following installation procedure, the top cover must be removed and the registration board unlocked and tilted up.

INSTALLATION PROCEDURE

- STEP 1. De-energize the system and remove the main power cord.
- STEP 2. The Analog RGB2 module is installed into the fourth slot from the left as view from the rear.
- STEP 3. If the TTL/VGA module has been previously installed, or the TEST/TEXT module is located in the fourth slot, remove the two 4-40 phillips screws/ lock washers and lift the respective module out.
- STEP 4. Install the Analog RGB2 module into the fourth slot position and secure with the two 4-40 screws/washers previously removed.
- STEP 5. Locate DIP switch SW4 on the CPU module. Change SW4-1 to the "ON" position, replace the power cord and energize the system. Refer to figure 3-16.
- STEP 6. Once the system has been initialized, use the numeric keypad and enter 70, then press the CODE button. The LCD read-out will display: [RGB2 INSTALLED].
- STEP 7. Return SW4-1 (CPU module) to the "OFF" position and enter 44 then press the CODE button [READ SWITCHES].
- STEP 8. To verify your installation enter 34, then press the CODE button [DISPLAYS BOARD STATUS ON LCD].

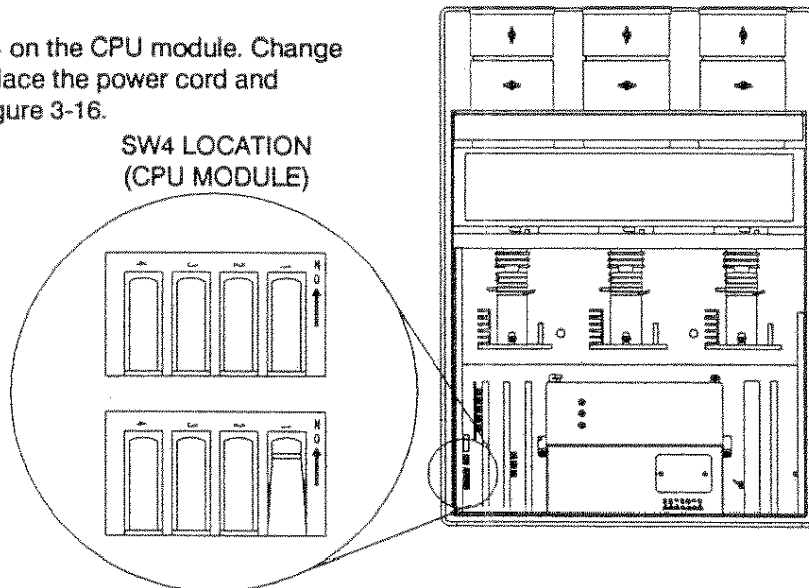

FIGURE 3-16. ADDING THE ANALOG RGB2 MODULE.
LOCATION OF DIP SWITCH SW4 (CPU MODULE)

ADDITIONAL CODES

73 CODE: CLEAR ALL MODULES

74 CODE: CLEAR TTL MODULE

NOTE: Refer to your operation manual for the operation and selection of the Analog RGB2 mode of operation.

NOTES:

TEST/TEXT INTERFACE (80785) REPLACEMENT PROCEDURE

TOOLS REQUIRED



REPLACEMENT PROCEDURE

- STEP 1. Disconnect the main A.C. power cord.
- STEP 2. Remove the top cover assembly. Unlock and tilt up the Registration board.
- STEP 3. Remove the the two 4-40 phillips screws and lock washers mounting the Test/Text module to the rear panel. See Figure 3-17.
- STEP 4. Remove the Test/Text module from the main chassis.
- STEP 5. Install the replacement module and secure with the hardware previously removed.
- STEP 6. Lower and lock the Registration board into place and replace the top cover assembly.
- STEP 7. Initialize the system and verify the operation of the Test/Text module.

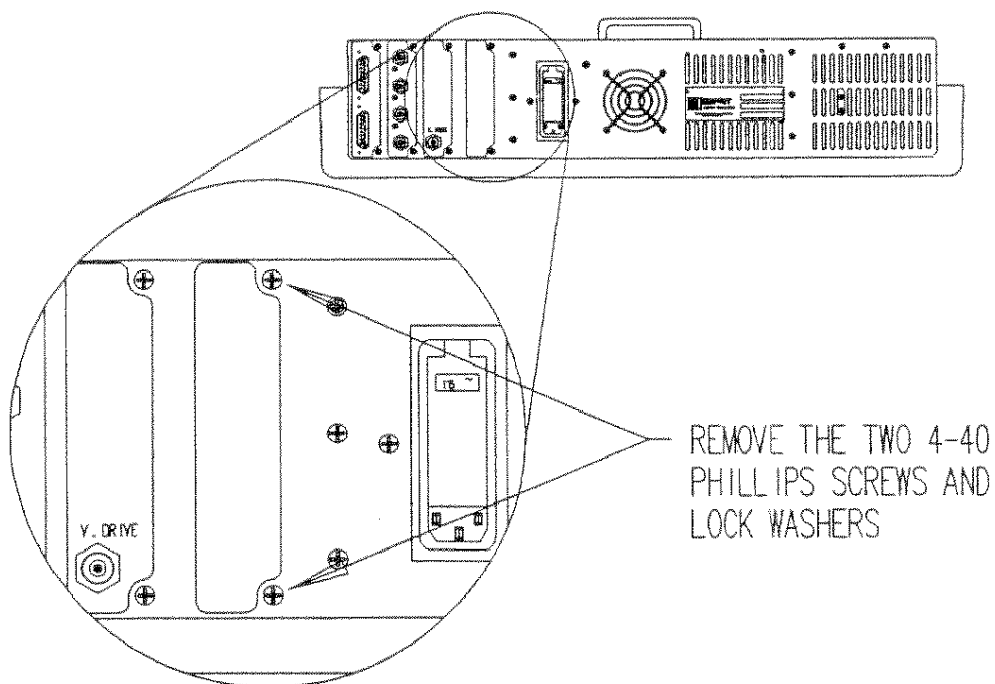
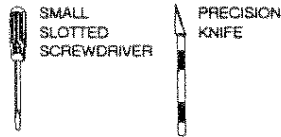

FIGURE 3-17. TEST/TEXT MODULE REPLACEMENT PROCEDURE.

NOTES:

CRT AMPLIFIER CARD (80880) REPLACEMENT PROCEDURE

TOOLS REQUIRED



REPLACEMENT PROCEDURE

- STEP 1. De-energize the system and remove the main A.C. power cord.
- STEP 2. Remove the top cover assembly. Unlock and tilt up the Registration board.
- STEP 3. Disconnect from the CRT Amplifier card: J1, J2 and the ground wire.
- STEP 4. Disconnect the focus lead from it's in-line connector.
- STEP 5. Disconnect the respective G2 connector from the mother board.
- STEP 6. If applicable, remove the black locking pin from the rear of the defective card. Additionally, cut away any RTV sealant that may be between the CRT and the CRT Amplifier card.
- STEP 7. Install the replacement CRT Amplifier card and reconnect all connections. (J1, J2, ground wire, G2, and Focus lead).

TOP VIEW

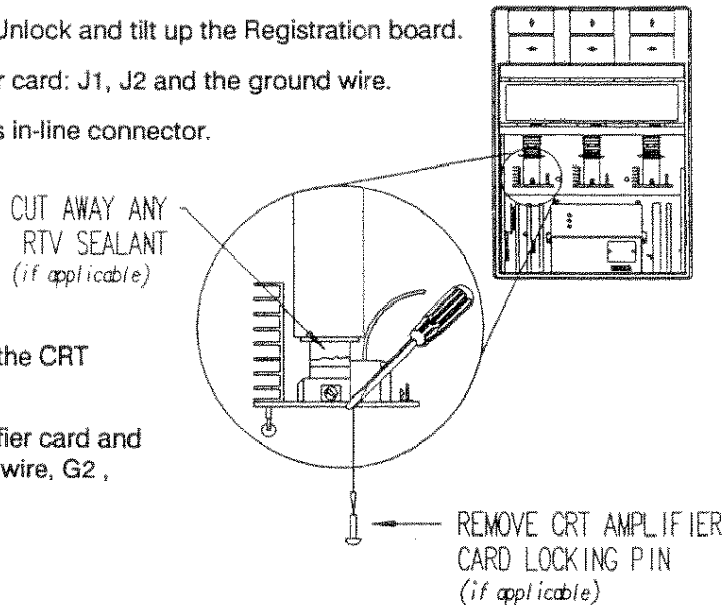

ADJUSTMENT PROCEDURE

- STEP 1. Apply main A.C. power and initialize the system.
- STEP 2. Cutoff all three colors via the Remote Control.
- STEP 3. Looking into each lens, adjust the respective G2 control until a raster is barely visible, then back off the G2 control until the raster just goes black.
- STEP 4. De-energize the system. Lower and lock the Registration board into place and replace the top cover assembly.

FIGURE 3-18. CRT AMPLIFIER CARD REPLACEMENT.

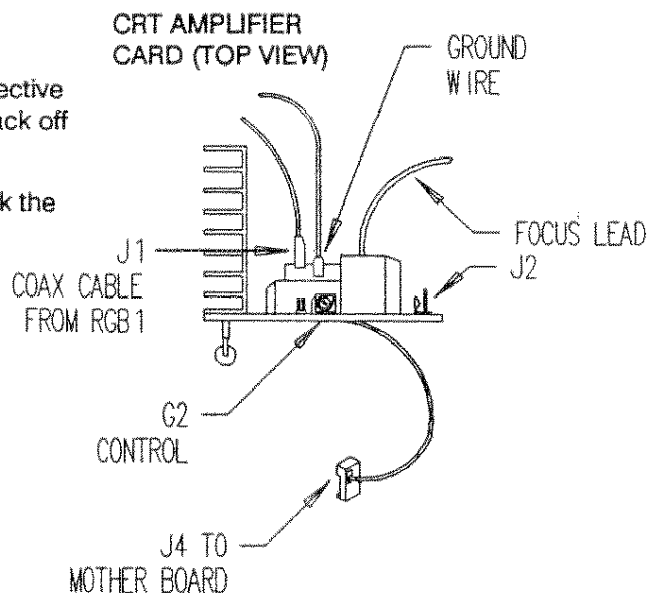

FIGURE 3-19. CRT AMPLIFIER CARD CONNECTIONS.

NOTES:

VERTICAL DEFLECTION MODULE (80833) REPLACEMENT PROCEDURE

TOOLS REQUIRED



REPLACEMENT PROCEDURE

- STEP 1. De-energize the system and remove the main A.C. power cord.
- STEP 2. Remove the top cover assembly. Unlock and tilt up the Registration board.
- STEP 3. Remove the single 4-40 phillips screw and lock washers from the Vertical Deflection module (third module from the right, as viewed from the rear) and lift this module out of the main chassis. Refer to Figure 3-20
- STEP 4. Install the replacement module and secure with the hardware previously removed.
- NOTE: Verify the position of the Vertical Configuration Switch. Ensure the switch is in it's proper position for your particular projection configuration. Refer to figure 3-20.
- STEP 5. Lower and lock into place the Registration board.
- STEP 6. Replace the top cover assembly.

ADJUSTMENT PROCEDURE

- STEP 1. Connect the main A.C. power cord and initialize the system.
- STEP 2. Select an internal 15.75kHz. crosshatch test pattern.
- STEP 3. Disable Registration (55 CODE).
- STEP 4. Turn off the Blue CRT.
- STEP 5. Using Green as your reference color, adjust the Red vertical height control (Figure 3-20) to overlay or equal (but opposite) the error from top to bottom, concentrating on the top and bottom horizontal lines.
- STEP 6. Using either Red or Green as your reference color, adjust the Blue vertical height control (Figure 3-20) in the same manner as described in Step 5.

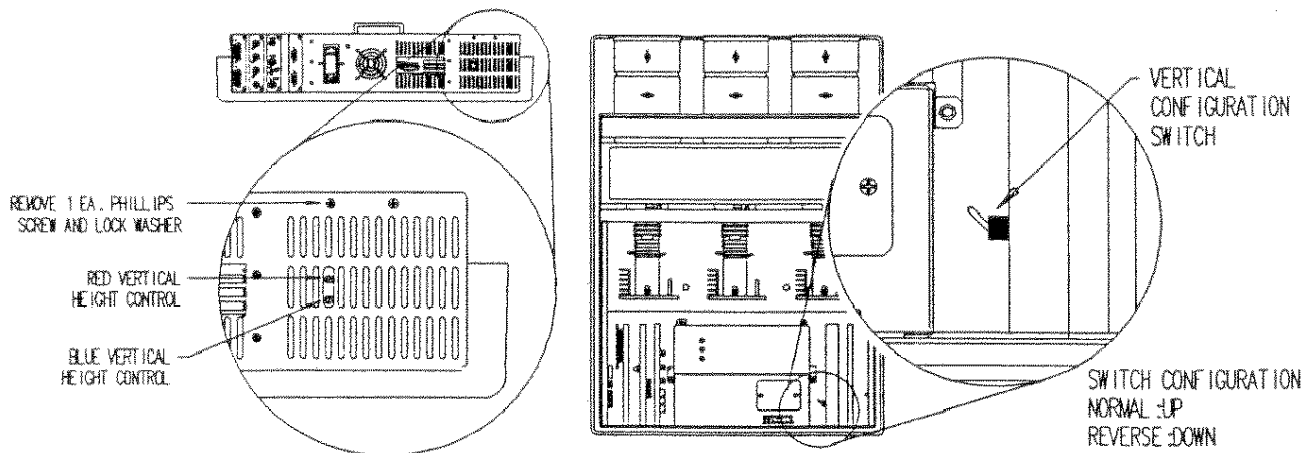

FIGURE 3-20. VERT. DEFLECTION MODULE REPLACEMENT.

NOTES:

HORIZONTAL DEFLECTION MODULE (D-80732/G-80762) REPLACEMENT PROCEDURE

TOOLS REQUIRED



REPLACEMENT PROCEDURE

- STEP 1. De-energize the system and remove the main A.C. power cord.
- STEP 2. Remove the top cover assembly. Unlock and tilt up the Registration board.
- STEP 3. Remove the 1 ea. 4-40 phillips screw and lock washers mounting the Horizontal Deflection module (second module from the right, as viewed from the rear), to the rear panel.
- STEP 4. Install the replacement module and secure with the hardware previously removed.
- STEP 5. Lower and lock the Registration board into place.
- STEP 6. Apply the main A.C. power and initialize the system.
- STEP 7. Verify the operation of the system by operating at the specified frequency of your particular system.
- STEP 8. Replace and secure the top cover assembly.

ADJUSTMENT PROCEDURE

- NONE

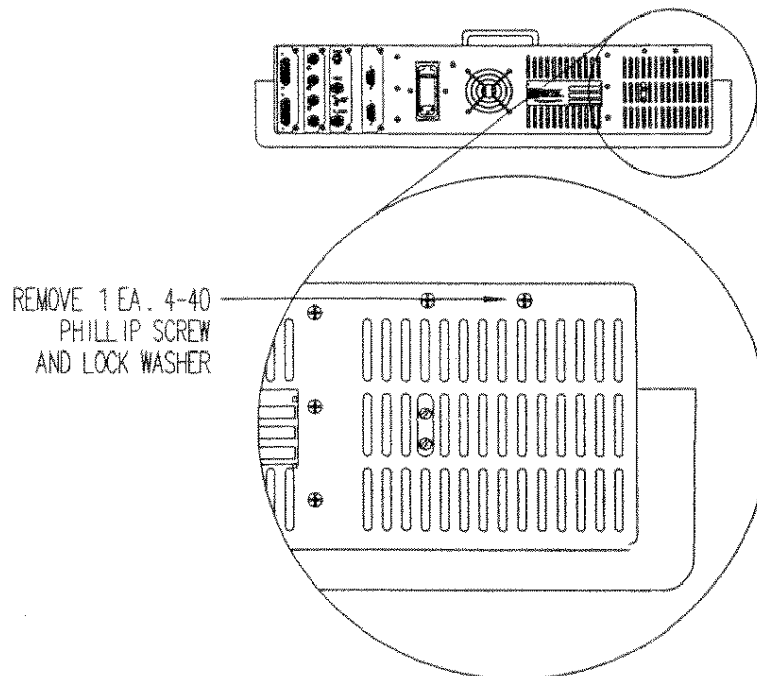
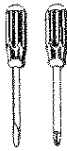

FIGURE 3-21. HORIZONTAL MODULE REPLACEMENT.

NOTES:

H.O.T. MODULE (80781) REPLACEMENT PROCEDURE

TOOLS REQUIRED



SMALL
SLOTTED AND
PHILLIPS
SCREWDRIVER

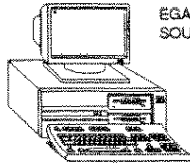

EGA
SOURCE

OR



MULTI-FREQUENCY
RGB VIDEO
GENERATOR

REPLACEMENT PROCEDURE

- STEP 1. With the system de-energized, disconnect the A.C. power cord.
- STEP 2. Remove the top cover assembly, unlock and tilt up the Registration board.
- STEP 3. Remove the 7 ea. phillips screws/lock washers which fasten the H.O.T. module to the right side of the system (as viewed from the rear).
NOTE: It may be necessary to remove the left rear top cover bracket. Refer to Figure 3-22.
- STEP 4. Disconnect the following plugs from the H.O.T.: P55, P56, P57, P58
- STEP 5. While installing the replacement H.O.T., connect the four molex connectors to their appropriate jacks (headers).
- STEP 6. Firmly seat the H.O.T module to the mother board connector and fasten with the hardware previously removed.

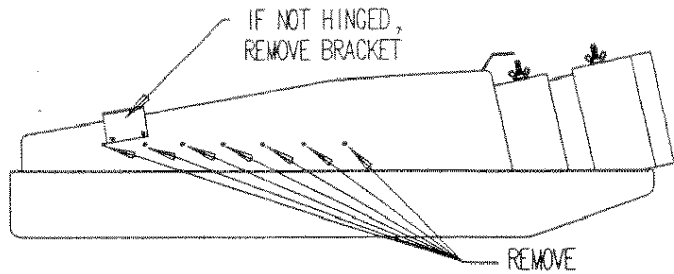
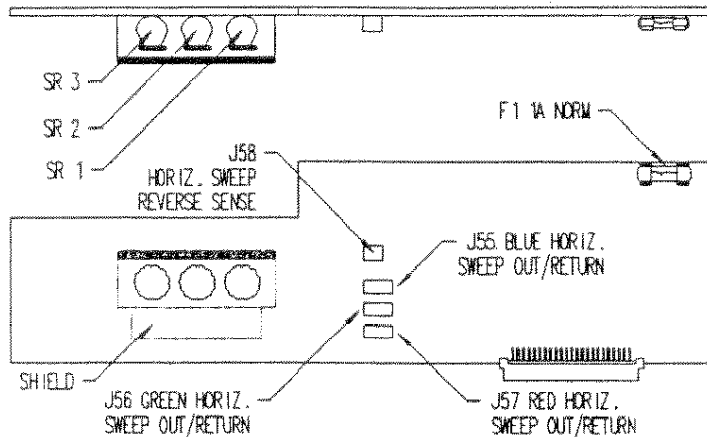

FIGURE 3-22. H.O.T. REPLACEMENT PROCEDURE.

ADJUSTMENT PROCEDURE

- STEP 1. Select an external or internal 31.5kHz. crosshatch test pattern and adjust SR-3 (Saturable Reactor 3) for optimum horizontal linearity.
- STEP 2. Select an external 21.85kHz crosshatch test pattern and adjust SR-2 (Saturable Reactor 2) for optimum horizontal linearity.
- STEP 3. Select an external or internal 15.75kHz. crosshatch test pattern and adjust SR-1 (Saturable Reactor 1) for optimum horizontal linearity.

H.O.T. (TOP VIEW)



H.O.T. (SIDE VIEW)

NOTES:

SWITCH MODE POWER SUPPLY (80725) REPLACEMENT PROCEDURE

TOOLS REQUIRED

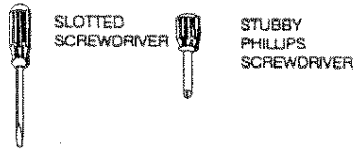

REPLACEMENT PROCEDURE

- STEP 1. Disconnect the A.C. power cord from the system.
- STEP 2. Remove the top cover assembly.
- STEP 3. Loosen the 4 ea. phillips screws located on both sides of the SMPS. Refer to Figure 3-23.
- STEP 4. Using the handle located on the top of the SMPS, gently pull the SMPS straight up and out of the SMPS cage.
- STEP 5. Remove the 4 ea. phillips screws and lock washers from the SMPS just removed and install into the replacement SMPS.
- STEP 6. Install the replacement SMPS back into the SMPS cage and tighten the 4 ea. retaining screws. Ensure the replacement SMPS is firmly seated.
- STEP 7. Apply the main A.C. power and energize the system using the remote control.
- NOTE 1: Ensure all low voltage power LEDs are illuminated.
- STEP 8. Replace the top cover assembly.
- NOTE 2: No field adjustments are required.

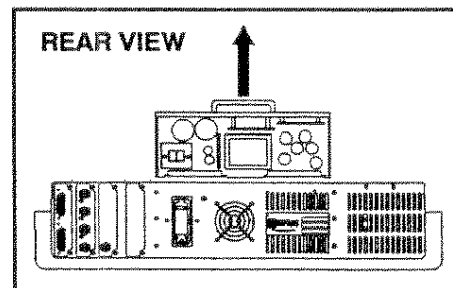
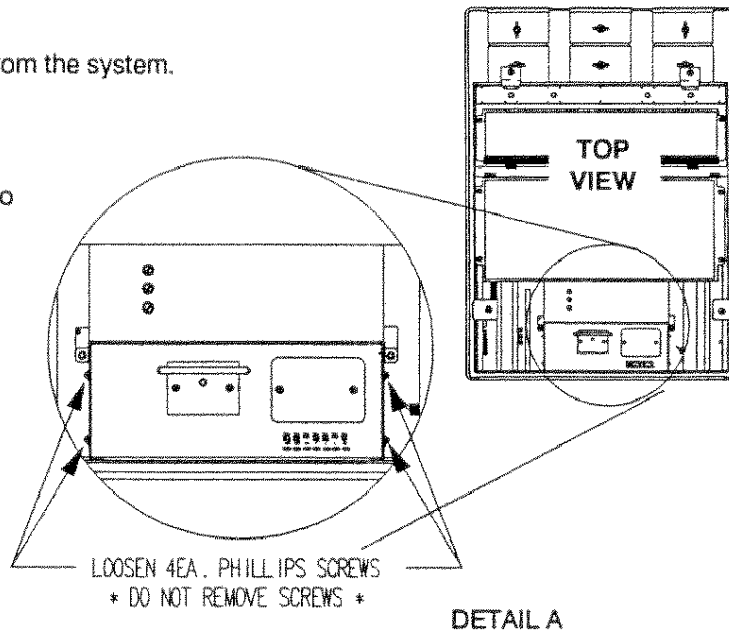
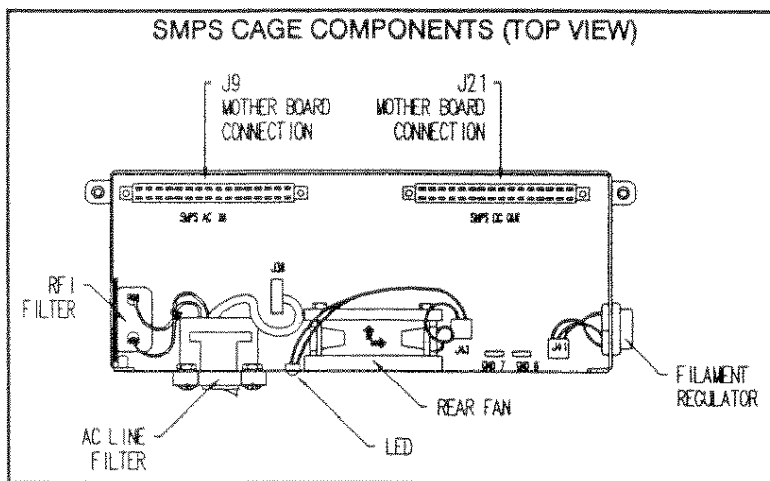

FIGURE 3-23. SMPS REMOVAL PROCEDURE.



NOTES:

REGISTRATION BOARD (80702) REPLACEMENT PROCEDURE

TOOLS REQUIRED



REPLACEMENT PROCEDURE

- STEP 1. Disconnect the main A.C. power cord.
- STEP 2. On the Registration board, disconnect J50 (from Registration to Registration Amplifier board).
- STEP 3. Unlock and tilt up the Registration board.
- STEP 4. On the underside of the Registration board, disconnect J51 (ribbon cable), J72 and the ground wires (2 ea.).
- STEP 5. Carefully, remove the Registration board from the crossbar.
- STEP 6. Install the replacement Registration board. Reconnect all connectors and lock into place.
- NOTE 1: Ensure that LK7 and LK8 (lower right corner of the Registration board), are in the proper positions for your particular projection configuration.
- NOTE 2: Some registration touch-up may be required.
- NOTE 3: Upon completion of your work, replace the top cover assembly.

REGISTRATION BOARD (TOP VIEW)

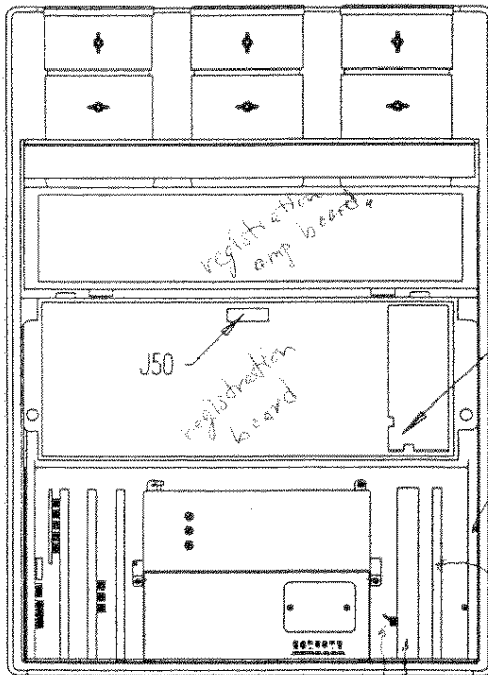

ENSURE LK7 AND LK8 ARE IN THE PROPER POSITIONS FOR YOUR PARTICULAR PROJECTION CONFIGURATION.

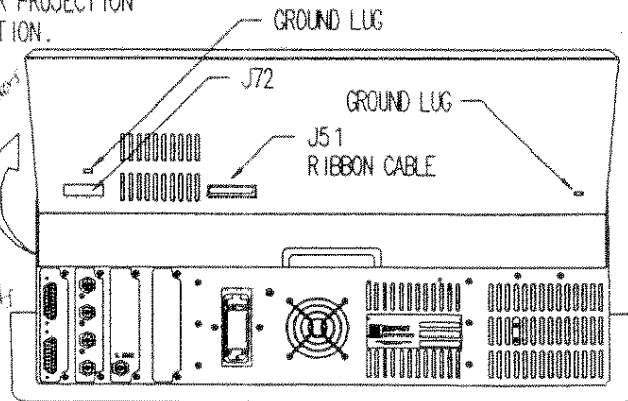

REGISTRATION BOARD (UNDERSIDE-REAR VIEW)

FIGURE 3-24. REGISTRATION BOARD REPLACEMENT.

NOTES:

REGISTRATION AMPLIFIER BOARD (80735) REPLACEMENT PROCEDURE

TOOLS REQUIRED



REPLACEMENT PROCEDURE

- STEP 1. Disconnect the main A.C. power cord.
- STEP 2. Remove the top cover assembly.
- STEP 3. On the top side of the Registration Amplifier board, remove J46.
- STEP 4. Unlock and tilt up the Registration Amplifier board.
- STEP 5. Disconnect J48, J49, J50, J147 and the ground wire located on the underside of this board and carefully pull the board from it's clips.
- STEP 6. Install the replacement Registration Amplifier and reconnect J46 (topside) and J48, J49, J50, J149 and the ground wire (underside).
- STEP 7. Lower the board and lock into place.
- STEP 8. Replace the top cover assembly.

ADJUSTMENT PROCEDURE

- NONE

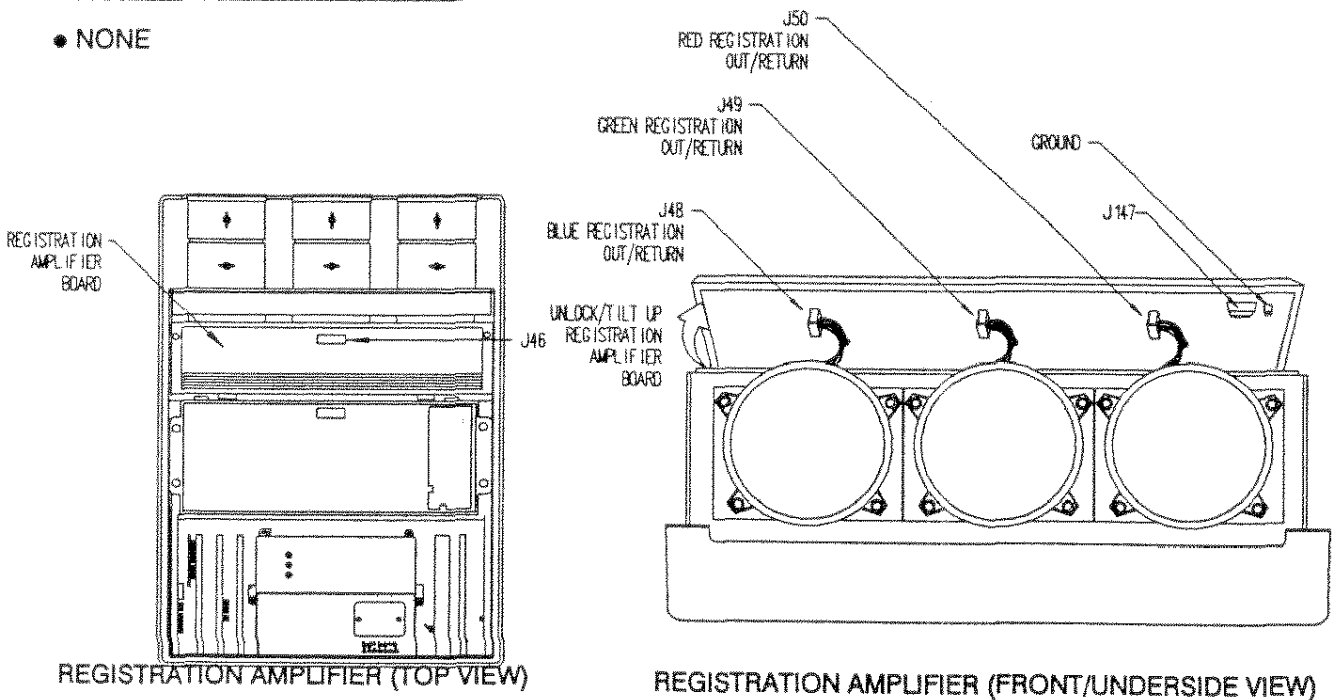
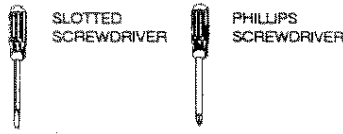

FIGURE 3-25. REGISTRATION AMPLIFIER REPLACEMENT.

NOTES:

HIGH VOLTAGE POWER SUPPLY (80816) REPLACEMENT PROCEDURE

TOOLS REQUIRED



REPLACEMENT PROCEDURE

- STEP 1. Ensure the system is powered down and disconnect the main A.C. power cord.
- STEP 2. Remove the top cover, unlock and tilt up the Registration board.
- STEP 3. Disconnect the following plugs from the HVPS.
 - J42 (HVPS TO MOTHER BOARD)
 - J44 (HVPS TO MOTHER BOARD)
 - ANODE CONNECTIONS (J3, J4, J5)
 - FOCUS LEADS (P3, P4, P5)
- STEP 4. Remove the 4 ea. phillips screws and lock washers located at the front and sides of the HVPS. Refer to Figure 3-26
- NOTE 1: It may become necessary to remove both the Test/Text interface module (or any module in that position) and the Vertical Deflection module.
- STEP 5. Lift-out the HVPS of the main chassis.
- STEP 6. Install the replacement HVPS, and secure with the hardware previously removed.
- STEP 7. Re-connector all plugs.
- NOTE 2: Reverse Step 2.

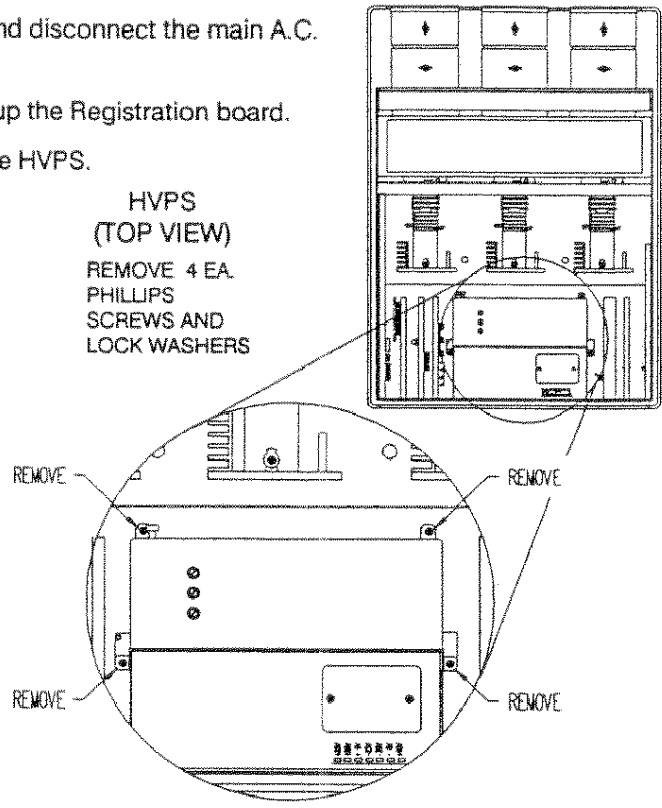
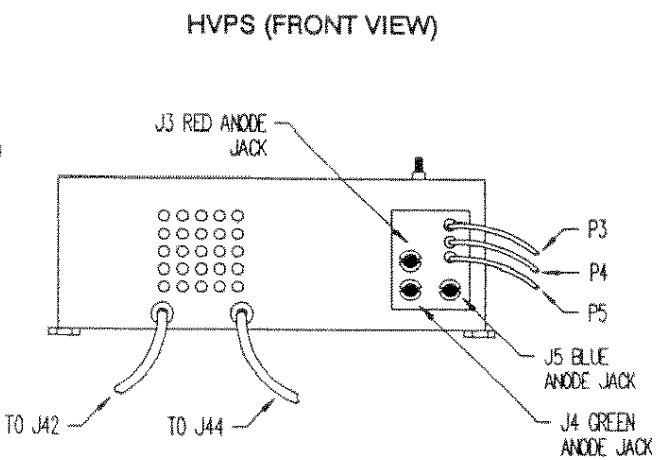
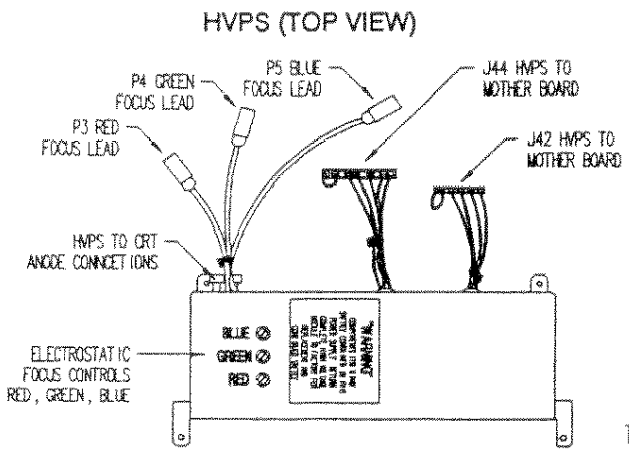

FIGURE 3-26. HVPS REMOVAL/REPLACEMENT.



NOTES:

7" CRT REPLACEMENT PROCEDURE

TOOLS REQUIRED

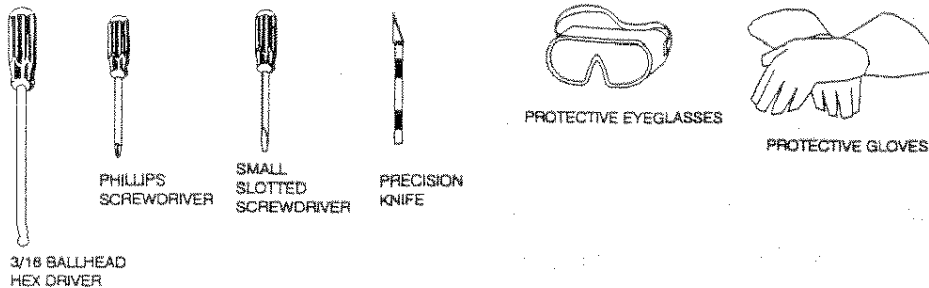

CRT REMOVAL PROCEDURE

- STEP 1. Disconnect the A.C. power supplied to the system.
- STEP 2. Remove the top cover assembly. Disconnect, unlock and remove the Registration and Registration Amplifier boards. Refer to pages 3-31 and 3-33 for additional information.
- STEP 3. Perform the following on the CRT to be removed:
 - A. Place an alignment mark from the Deflection Yoke assembly to the Registration Coil assembly. This alignment mark will be used to ensure proper alignment between these two assemblies during installation of the replacement CRT.

B. Remove the CRT Amplifier card located at the rear of the CRT. **NOTE:** It may be necessary to remove the small black locking pin located in the center near the bottom of the CRT Amp Card. Refer to Figure 3-27 (insert). Additionally, cut away any RTV sealant that may be between the CRT and CRT Amp card.

C. Loosen the three clamps securing the Astigmator/Beam centering rings, Registration Coil and Deflection Yoke assemblies.

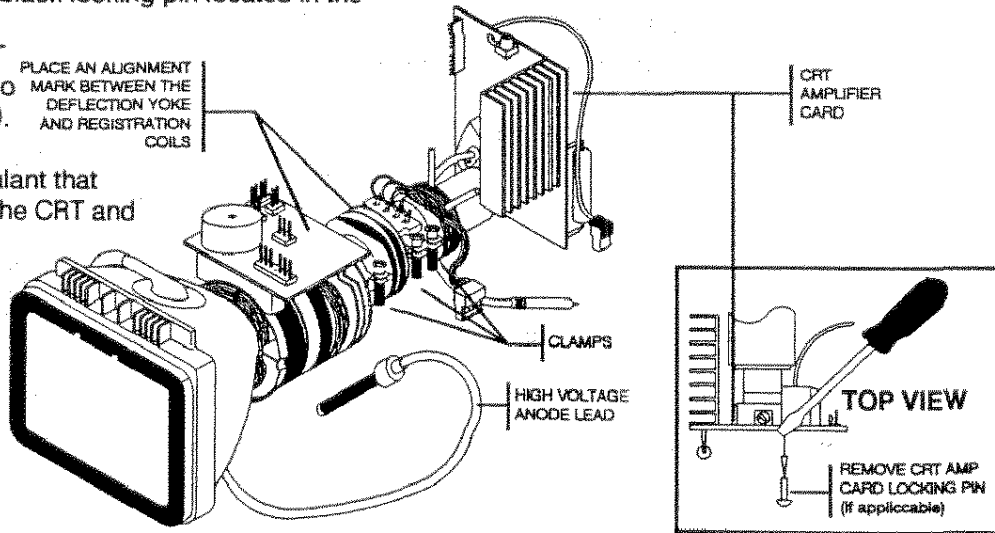

FIGURE 3-27. CRT REMOVAL PROCEDURE.

D. Disconnect the respective High Voltage Anode Lead from the High Voltage Power Supply (HVPS).

CRT REMOVAL PROCEDURE

- STEP 4. Remove Lens assembly:
 - A. Using your 3/16 lens adjustment tool, remove the three swivel screws and washers securing the lens assembly in place. Refer to Figure 3-28, Item A. **NOTE: DO NOT TOUCH** the coated rear element of the lens.
 - B. Place lens cover (originally supplied with the system) onto the front element of the lens. Place lens assembly (cover down) in a secure location.
 - C. Remove the three springs (Item E) from the CRT coupler assembly (item F).
- STEP 5. Remove the 6 ea. phillips 10-32 CRT black retaining screws. Refer to Figure 3-28, Item C.
- STEP 6. With the appropriate protective eyeglasses and gloves on, remove the CRT (item D) from the coupler assembly (item F), while sliding the Deflection Yoke, Registration coils and Astigmator/centering rings and associated clamps off the neck of the CRT. **NOTE:** Take notice of the CRT to Coupler grounding fingers. Refer to Figure 3-28, Item G.

IMPORTANT NOTES

- 1. Reverse the order of the removal procedure when installing the replacement CRT.
- 2. When installing replacement CRT, ensure grounding fingers are making proper contact to CRT.
- 3. Ensure the Deflection Yoke is pushed as far up on the bell of the CRT as possible.
- 4. Prior to installing the lens assembly, remove any smudges or fingers prints from the faceplate of the CRT by using Windex and a clean soft cloth.
- 5. **DO NOT TOUCH OR CLEAN** the coated rear element of the lens.
- 6. Refer to the CRT REPLACEMENT SETUP PROCEDURE to realign the replacement CRT.

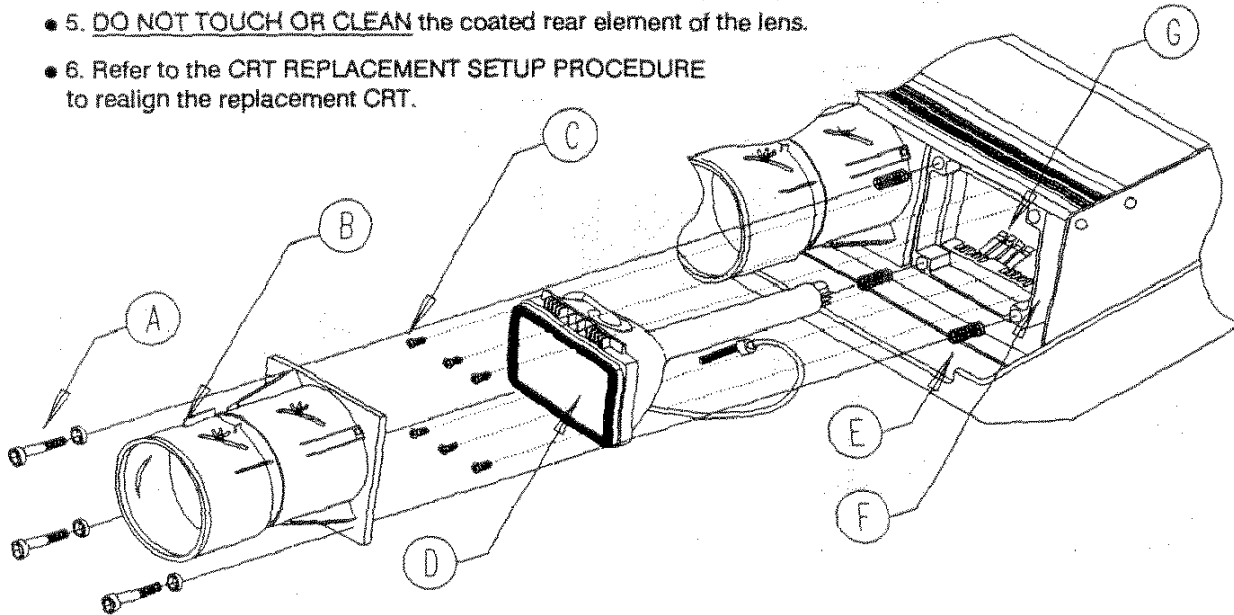

FIGURE 3-28. LENS, CRT REMOVAL

CRT REPLACEMENT SETUP PROCEDURE

YOKE ROTATION

- STEP 1. Apply the appropriate A.C. power to the system.
- STEP 2. Toggle the A.C. rocker switch located on the rear panel to the "ON" position and energize the system using the remote control.
- STEP 3. Via the remote control select the internal 15kHz test CROSSHAIR pattern.
- STEP 4. Toggle Registration "OFF" (55 CODE) .
- STEP 5. Cut off one of the colors not under test via the remote control. Leaving "ON" the replacement CRT and a reference color.
- STEP 6. Loosen the Deflection Yoke clamp of the replacement CRT.
- STEP 7. Using the reference color, rotate the replacement CRT Deflection Yoke until the center horizontal line is parallel to the center horizontal line of the reference color. Refer to Figure 3-39.
- STEP 8. Tighten the Deflection Yoke clamp.

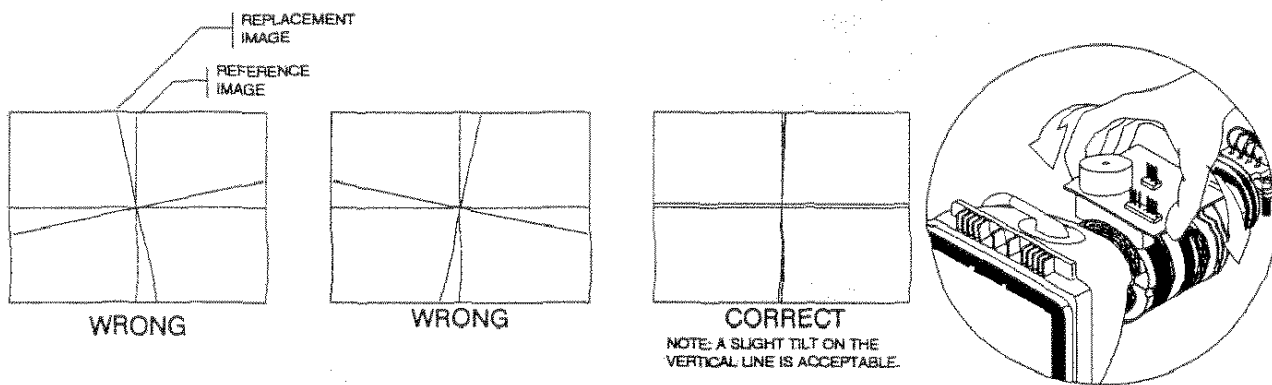

FIGURE 3-29. YOKE ROTATION PROCEDURE.

REGISTRATION COILS TO DEFLECTION YOKE ALIGNMENT

- STEP 1. Loosen the Registration Coil clamp.
- STEP 2. Rotate the Registration Coil assembly until the alignment marks between the Deflection Yoke and the Registration Coil match.
- STEP 3. Tighten the Registration Coil clamp.

IMPORTANT NOTES

- Refer to the Appendix A for further setup instructions.
- Perform the Focus and Registration (for all CHANNELS).

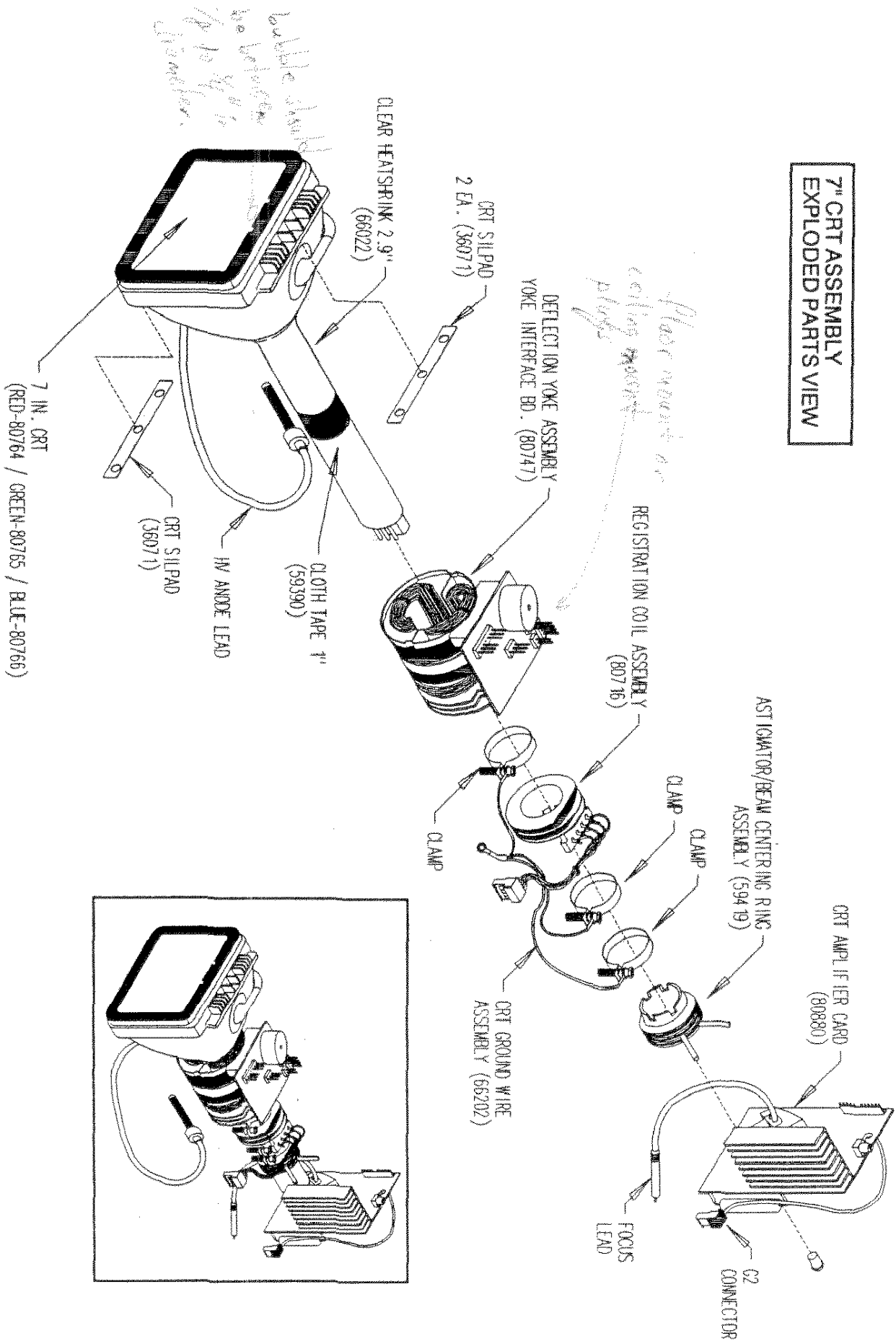

**LENS/BACKET ASSEMBLY
EXPLODED PARTS VIEW
(P/N: 80752)**

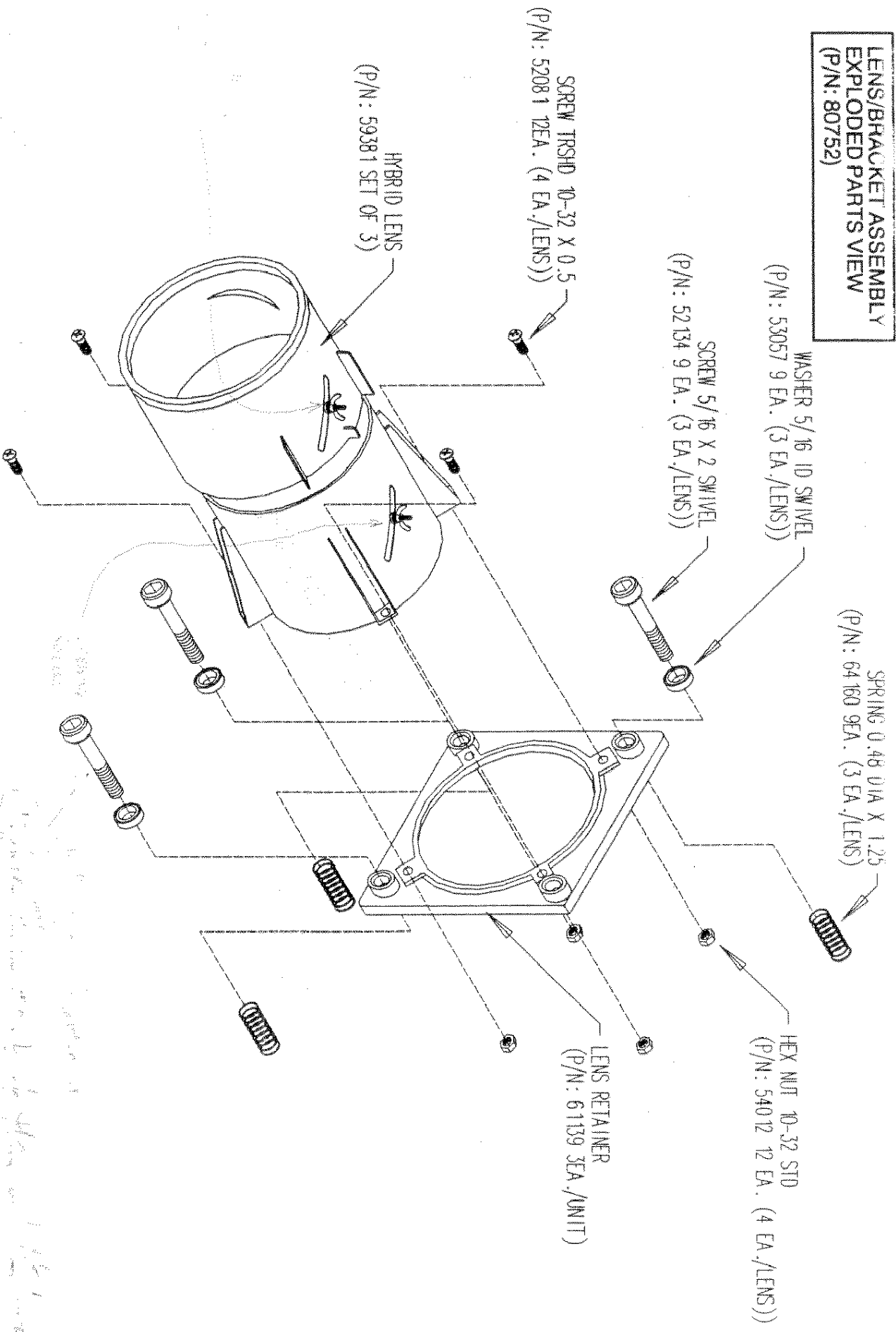

LENS/BACKET ASSEMBLY EXPLODED PARTS VIEW
FIGURE 3-31

7" CRT PIVOTING HEAD ASSEMBLY EXPLODED PARTS VIEW

FIGURE 3-32

7" PIVOTING HEAD ASSEMBLY EXPLODED PARTS VIEW (P/N: 80736)

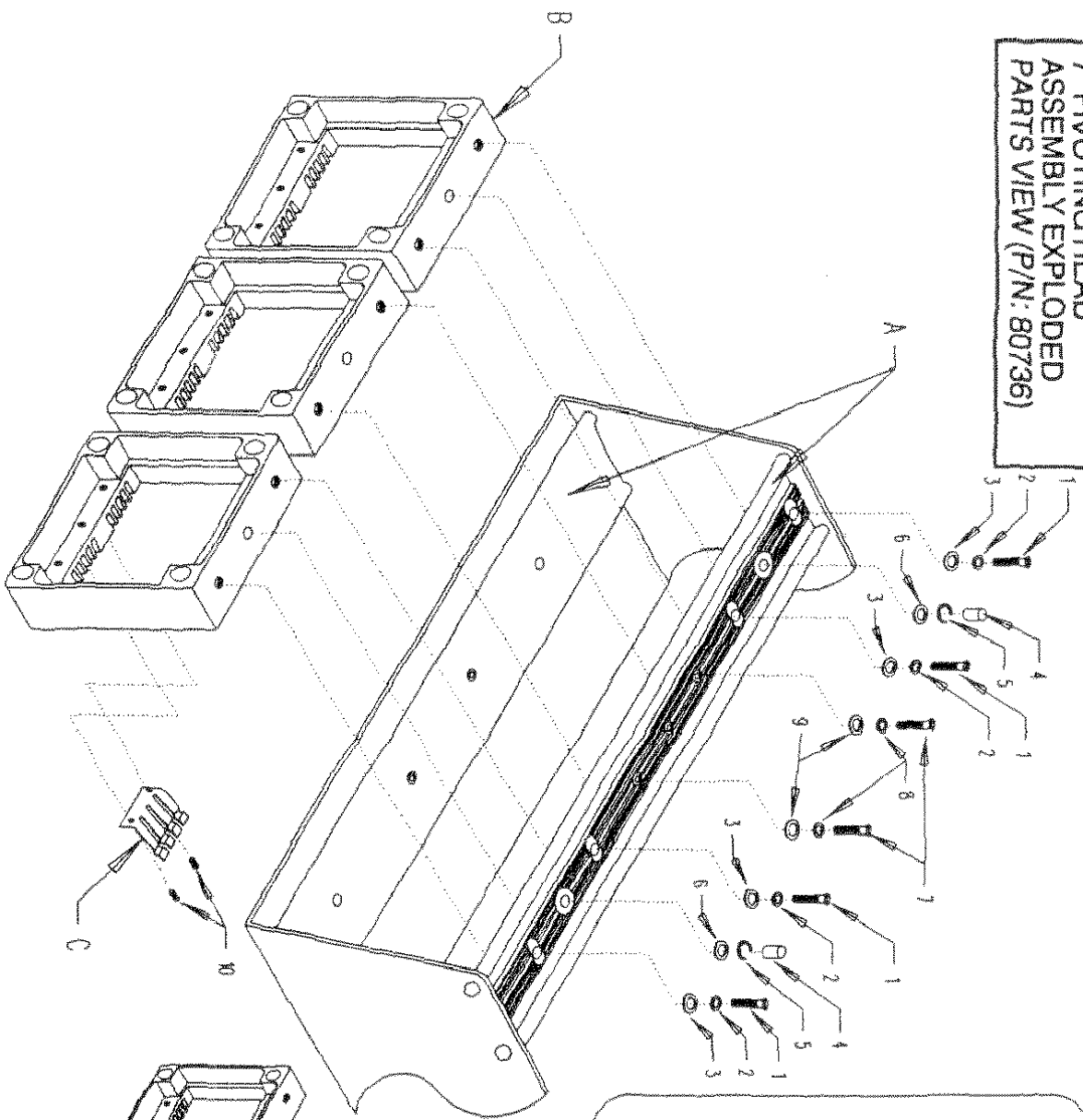

ITEM	DESCRIPTION	P/N	QTY
A	HEAD CROSS MEMBER	67219	2 EA.
B	TUBE RETAINER	67058	3 EA.
C	GROUNDING FINGERS	62185	3 EA.
1	SCREW 1/4-20 X 5/16 SKT CAP STL	52186	4 EA.
2	LOCKWASHER 1/4 BLNL	53064	4 EA.
3	WASHER 1/4 ID X 5/8 OD X .06	52063	8 EA.
4	PIVOT PIN 1/4"	59402	4 EA.
5	1/4 ARC RETAINER RING	53054	4 EA.
6	WASHER 1/4 X 3/4 X 0.01	53062	4 EA.
7	BOLT 1/4-20 X 3/4 HEX STL	52142	4 EA.
8	1/4 STL SPLIT LOCKWASHER	53046	4 EA.
9	SAME AS ITEM 3		
10	SCR PHD PHL 6-32 X .25 STL	52007	6 EA.

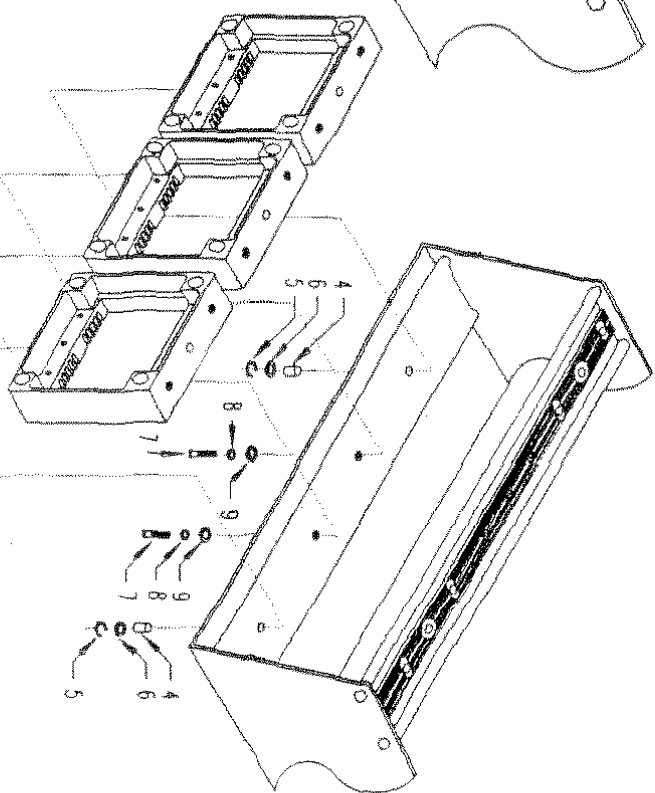

APPENDIX A

MODULE / CONTROL LOCATION AND ADJUSTMENT GUIDE



The adjustments outlined in this Appendix are to be performed only by qualified service technicians. Do not attempt to make any internal adjustments if you are not familiar with this system and the normal safety precautions pertaining to electrical and electronic equipment.

APPENDIX A INDEX

PROCEDURE	PAGE
ASTIGMATOR.....	A2
BEAM CENTERING.....	A2
ELECTROSTATIC FOCUS.....	A2
RED AND BLUE HEIGHT	A2
G2 CUTOFF ADJUSTMENTS.....	A2

NOTE: PRIOR TO MAKING ANY ADJUSTMENTS, REMOVE THE TOP COVER ASSEMBLY, UNLOCK AND TILT UP THE REGISTRATION BOARD.

ASTIGMATOR AND BEAM CENTERING ADJUSTMENTS:

BEAM CENTERING ADJUSTMENT:

- Pattern Required: Internal 15kHz Dot Pattern.
- Tools Required: Standard Slotted Screwdriver
- STEP 1: Unlock and lift up the registration board.
- STEP 2: Set brightness and contrast to maximum
- STEP 3: Cutoff two of the CRT's, and:
- STEP 4: Defocus the projected image using the electrostatic focus control (see controls 14, 15 and 16 - Detail B - Page A-3) in the counterclockwise direction so to cause a halo to form around the dots, producing a bright dot in the center of the halo. See Figure A-1.
- STEP 5: Adjust the beam centering ring (See Detail A-Page A-3), by twisting the knob and rotating the ring left and right to center the bright dot inside the halo, in both the horizontal and vertical direction. See Figure A-1.
- REPEAT FOR EACH COLOR



FIGURE A-1.

ASTIGMATOR ADJUSTMENT:

- Pattern Required: Internal 15kHz Dot Pattern.
- STEP 1: Cutoff two of the CRT's.
- STEP 2: Using the focus controls 14, 15, 16, electronically defocus (clockwise direction) the dot pattern until the dots increase in size.
- STEP 3: Adjust the astigmator ring (See Detail A - Page A-3), by twisting knob and rotating the ring left and right for optimum roundness of the center dots. See Figure A-2.
- STEP 4: Verify beam centering adjustment by defocusing in the counterclockwise direction. The bright spot should be centered in the round halo. Refer to Figure A-3.
- REPEAT FOR EACH COLOR



FIG. A-2. ASTIGMATOR EXAMPLES.

ELECTROSTATIC FOCUS ADJUSTMENTS:

- Pattern Required: Internal 15kHz Crosshatch Pattern 2 (Dense Hatch).
- STEP 1: Using the remote control set brightness and contrast to approximately 85% or to the desired operating settings.
- STEP 2: Displaying one color at a time, adjust the respective focus control, (controls 14, 15, and 16 - Detail B- Page 5), and adjust the projected image until optimum sharpness is achieved.
- REPEAT FOR EACH COLOR

WIDTH COIL ADJUSTMENT:

- Pattern Required: Internal Crosshatch At 15kHz Or Desired Frequency.
- Tool Required: .075" Plastic Hex Alignment Tool.
- STEP 1: Unlock and lift up the registration amplifier board. locate each CRT Yoke Interface Board and the individual width coil. See Detail A - Page A-3.
- STEP 2: Using Green as the reference color (for the smallest image) match the Red image using the respective width coil and adjusting the slug to the Green image (or reference color) as to have equal but opposite error from left to right.
- STEP 3: Again using Green as the reference color, repeat the above step for Green to Blue adjustment.

RED/BLUE HEIGHT ADJUSTMENTS:

- Pattern Required: Internal Crosshatch At 15kHz Or Desired Frequency.
- Tool Required: Small Slotted Screwdriver.
- STEP 1: Using Green as the reference color, adjust the Red Vertical Height control, (Refer to Page 3-23 for control location) to overlay or equal (but opposite) the error from top to bottom concentrating on the top and bottom horizontal lines.
- STEP 2: Using either Red or Green as the reference color, adjust the Blue Vertical Height control, (Refer to Page 3-23 for control location) to overlay or equal, but opposite the error from top to bottom, concentrate on the top and bottom horizontal line.

G2 CUTOFF ADJUSTMENTS:

- Pattern Required: None
- STEP 1: Cutoff all three colors using the Remote Control [CUTOFF] button.
- STEP 2: Unlock and lift up the registration board and locate each G2 control. See Detail A - Page A-3.
- STEP 3: Looking into each lens, adjust the respective G2 control until the raster on the face of the CRT is just extinguished.
- STEP 4: If no raster is visible, adjust the G2 control until the raster on the face of the CRT is visible and follow STEP 3.
- REPEAT FOR EACH COLOR.

High level then step to good dots.

CONTROL NUMBER	DESCRIPTION	MODULE
1	L.E.D. BAR INDICATOR	CPU
2	4 POSITION DIP SWITCH	CPU
3	HEX SWITCH (S3) BAUD RATE	CPU
4	HEX SWITCH (S2) ADDRESS	CPU
5	HEX SWITCH (S1) ADDRESS	CPU
6	SYNC ON GREEN SUB-BRITE	ANALOG RGB1
7	GREEN SUB-BRITE	ANALOG RGB1
8	BLUE SUB-BRITE	ANALOG RGB1
9	RED SUB-BRITE	ANALOG RGB1
10	MASTER SUB-BRITE	ANALOG RGB1
11	RED SUB-CONTRAST	QUAD VIDEO
12	BLUE SUB-CONTRAST	QUAD VIDEO
13	NOT ACTIVE	QUAD VIDEO
14	BLUE ELECTROSTATIC FOCUS	HVPS
15	GRN ELECTROSTATIC FOCUS	HVPS
16	RED ELECTROSTATIC FOCUS	HVPS
17	VERT. SWEEP REVERSE SWITCH	VERT. DEFL
18	MASTER WIDTH	H.O.T

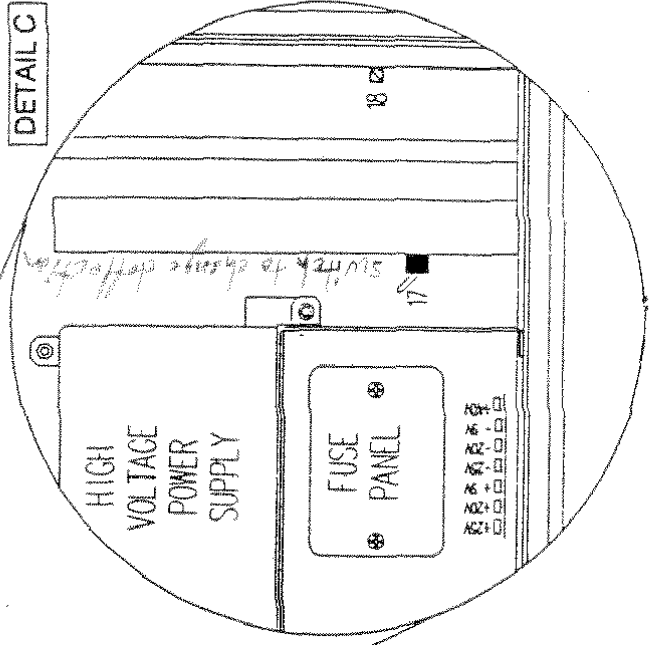
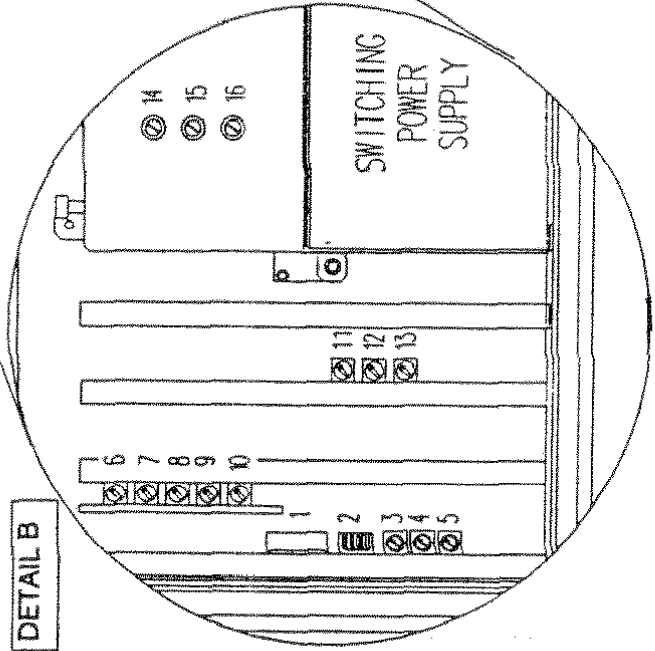
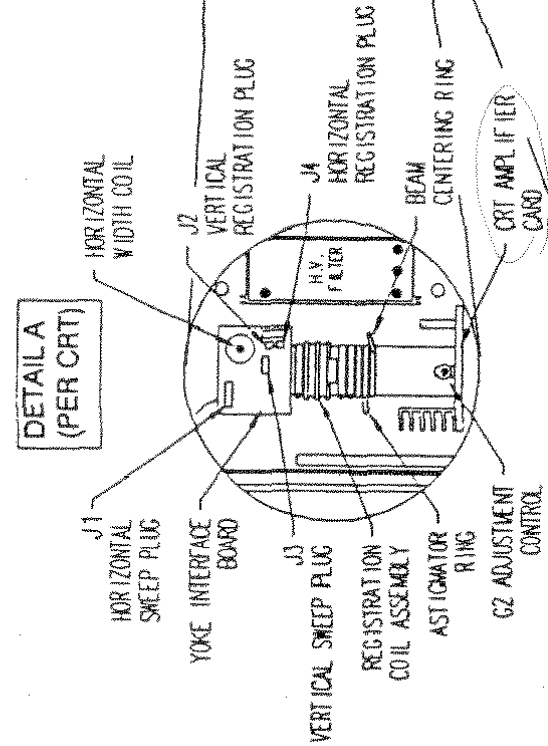
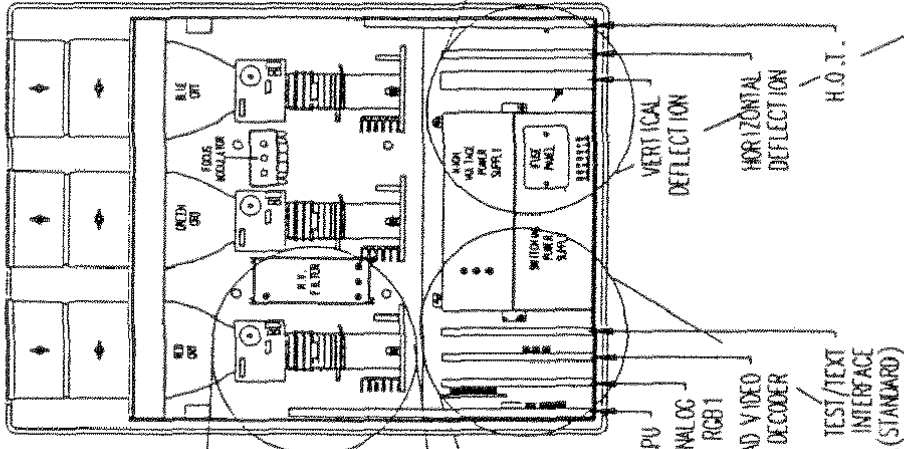

MODULE AND CONTROL LOCATIONS

FIGURE A-3

NOTES:

[Faint, illegible text, possibly bleed-through from the reverse side of the page]



Supplement 5

Optional Module(s) Installation

S5.1Installation Procedure:

- ⊠ NOTE: For the following installation procedure, de-energize the system and remove the main power cord and the top cover must be removed and the registration board unlocked and tilted up.
- STEP 1. Please refer to Figure S5-1 for the proper optional module slot position.

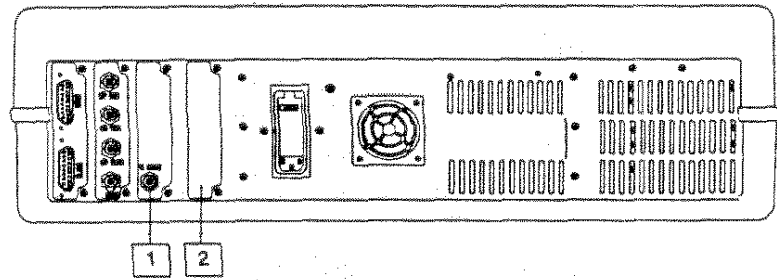

MODULE CONFIGURATION		
SLOT	STANDARD	OPTIONAL
1	VERTICAL DRIVE PANEL	ANALOG RGB2
2	BLANK PANEL	QUAD VIDEO DECODER (QVD)

FIGURE S5-1.

- STEP 2. Remove the existing module (panel) from the desired module position by removing the two 4- 40 phillips head screws and lift out that particular module (panel).
- STEP 3. With the appropriate slot empty, insert the desired optional module and secure with the two 4-40 screws.
- STEP 4. Locate DIP switch SW3 on the CPU module. Change SW3-6 to the "ON" position, replace the power cord and energize the system. Refer to Figure S5-2.
- STEP 5. Once the system has been energized, use the numeric keypad and enter 70, then press the [CODE] button.
- STEP 6. Upon entering the 70 [CODE] the LCD read-out will display the system's current module configuration . Using the UP and DOWN arrow keys, scroll through the listings until the LCD displays the new module configuration, then press [CODE] to select.
- ⊠ NOTE: All 50 channel locations will be automatically reset to operate in the Analog RGB1 mode of operation. Channel reassignment will be required.
- STEP 7. Return SW3-6 (CPU module) to the "OFF" position and enter 44 [CODE] (READ SWITCHES).
- STEP 8. To verify your installation enter 34 [CODE] and view the LCD read-out.
- ⊠ NOTE: Refer to Sections 6 and 7 for the operation and selection of the various modes of operation.

Optional Module(s) Installation

S5.1.1 . . . SW3 - (position) 6 Location:

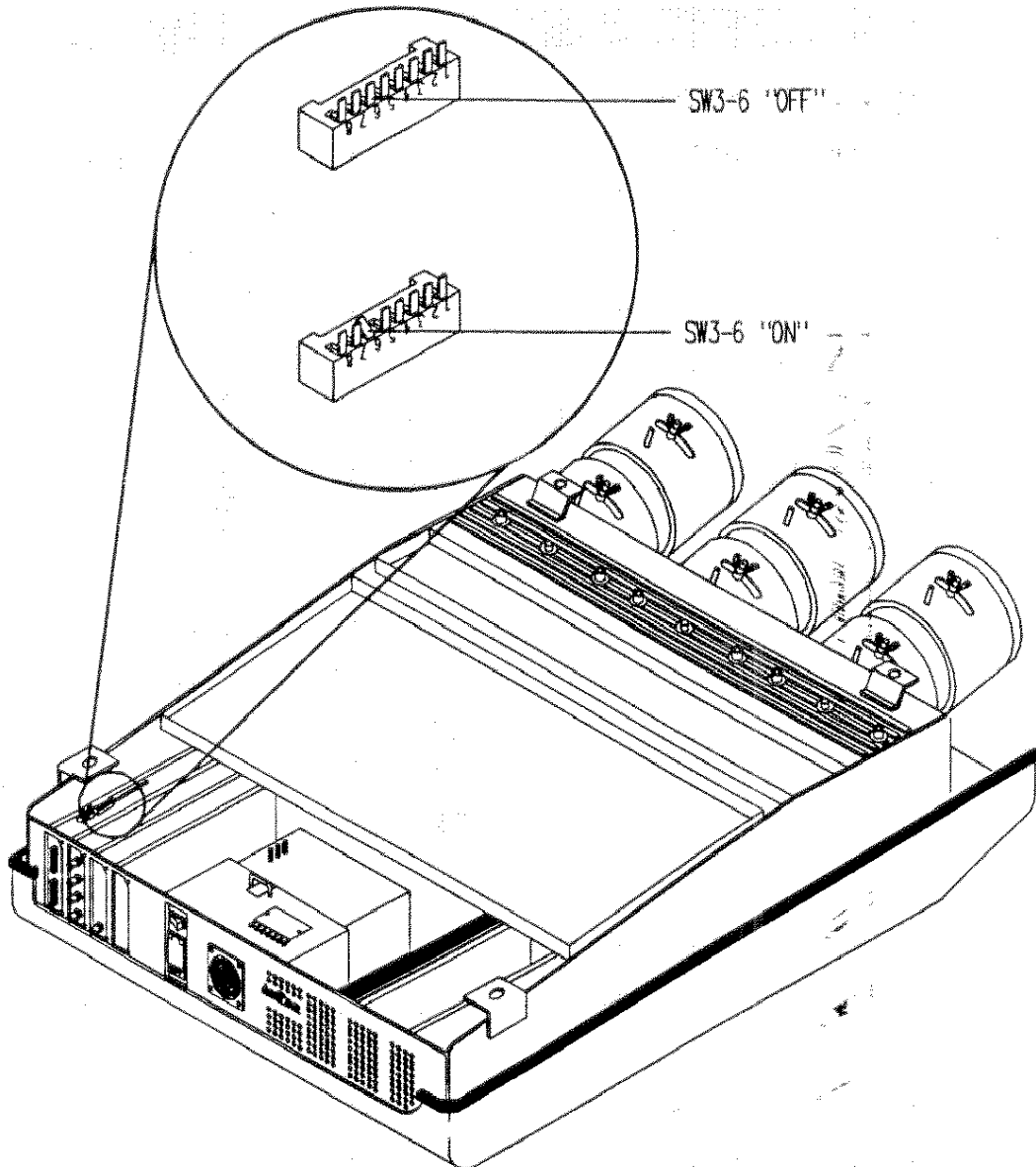

S5

FIGURE 5-2. SW3-6 Location / configuration.

APPENDIX D

OPTIONAL MODULE(S) INSTALLATION

1.0INSTALLATION PROCEDURE:

- NOTE: For the following installation procedure, the top cover must be removed and the registration board unlocked and tilted up.

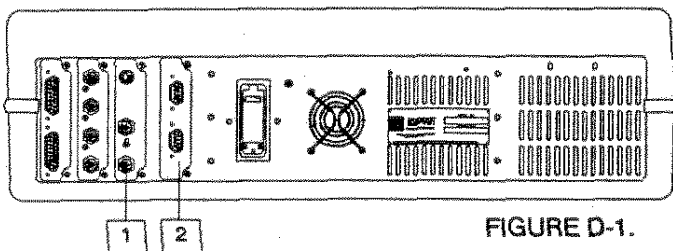

FIGURE D-1.

MODULE CONFIGURATION		
SLOT	STANDARD	OPTIONAL
1	VERTICAL DRIVE PANEL	QUAD VIDEO DECODER
2	TEST/TEXT INTERFACE	ANALOG RGB1 OR TTL/VGA

- STEP 1. De-energize the system and remove the main power cord.
- STEP 2. Please refer to Figure D-1 for the proper optional module slot position.
- STEP 3. Remove the existing module (panel) from the desired module position by remove the two 4- 40 phillips head screws and lift out that particular module (panel).
- STEP 4. With the appropriate slot empty, insert the desired optional module and secure with the two 4-40 screws.
- STEP 5. Locate DIP switch SW4 on the CPU module. Change SW4-1 to the "ON" position, replace the power cord and energize the system. Refer to Figure D-2.

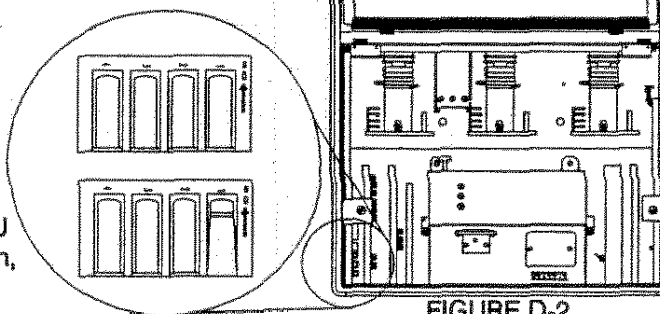

FIGURE D-2.

- STEP 6. Once the system has been energized, use the numeric keypad and enter 70, then press the CODE button.
- STEP 7. Using the reference table below, enter the appropriate configuration number that applies to your system. NOTE: All channels will be reset to the Analog RGB1 mode of operation.

MODULE STATUS REFERENCE TABLE					
ENTER	MODULE(S) INSTALLED	ENTER	MODULE(S) INSTALLED	ENTER	MODULE(S) INSTALLED
0	RGB1	3	RGB1 + QUAD VIDEO + RGB2	6 & 7	NOT USED
1	RGB1 + QUAD VIDEO	4	RGB1 + TTL	8	RGB1 + HDTV
2	RGB1 + RGB2	5	RGB1 + TTL + QUAD VIDEO	9	RGB1 + HDTV + QUAD VIDEO

- STEP 8. Return SW4-1 (CPU module) to the "OFF" position and enter 44 then press the CODE button [READ SWITCHES].
- STEP 9. To verify your installation enter 34, then press the CODE button and view the LCD read-out.
- NOTE: Refer to your particular operation manual for the operation and selection of the Various Modes of operation.

1. The first part of the document discusses the importance of maintaining accurate records of all transactions and activities. It emphasizes that this is crucial for ensuring transparency and accountability in the organization's operations.

2. The second part of the document outlines the various methods and tools used to collect and analyze data. It highlights the need for consistent data collection procedures and the use of advanced analytical techniques to derive meaningful insights from the data.

3. The third part of the document focuses on the implementation of data-driven decision-making processes. It provides a detailed overview of the steps involved in identifying key performance indicators (KPIs) and how they are used to monitor and improve organizational performance.

4. The fourth part of the document discusses the challenges and risks associated with data management and analysis. It addresses issues such as data quality, security, and privacy, and offers strategies to mitigate these risks and ensure the integrity of the data.

5. The fifth part of the document provides a comprehensive overview of the current state of data science and its applications in various industries. It highlights the growing importance of data in driving innovation and competitive advantage in the modern business landscape.

6. The sixth part of the document discusses the future trends and opportunities in data science. It explores emerging technologies such as artificial intelligence and machine learning, and their potential to revolutionize data analysis and decision-making.

7. The seventh part of the document provides a detailed overview of the ethical considerations surrounding data science. It discusses the importance of responsible data use and the need to address concerns related to bias, discrimination, and privacy.

8. The eighth part of the document discusses the role of data science in public policy and social issues. It highlights the potential of data to inform policy-making and address societal challenges, while also emphasizing the need for careful oversight and regulation.

9. The ninth part of the document provides a detailed overview of the career opportunities in data science. It discusses the various roles and responsibilities in the field, as well as the skills and qualifications required for success in these positions.

10. The tenth part of the document concludes with a summary of the key findings and recommendations. It emphasizes the importance of a data-driven approach to organizational management and the need for continuous learning and adaptation in the rapidly evolving field of data science.

ACTIVE LINE TIME - The "visible" time of one horizontal scan line which produces the picture information. Refer to Figure 1.

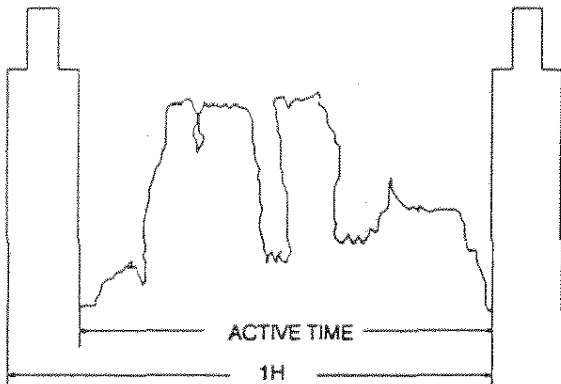

FIG. 1 ACTIVE LINE TIME.

AMBIENT LIGHT - Normal (surrounding) room light.

ANALOG VIDEO - A electrical signal that varies in frequency and amplitude. This term is typically associated with certain computer/video outputs.

ASPECT RATIO - The ratio of picture width to picture height. In the U.S. the standard picture ratio is 4:3.

AUTOLOCK - The ability of a display device to lock (*synchronize*) with multi-frequencies, (*within the given specifications*) without external adjustments from the user.

AXIS- A line that is fixed, along which distances are measured or to which positions are referenced.

BACK PORCH TIME - In a composite video signal it is the time between the trailing edge of a horizontal sync pulse and the trailing edge of the blanking pulse. Color burst is not considered part of the back porch. Refer to Figure 2.

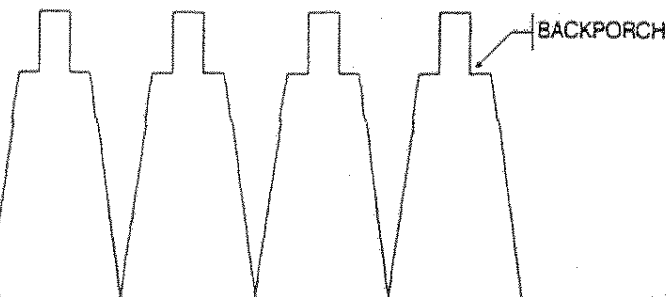

FIG. 2 BACKPORCH TIME.

BANDWIDTH - In a given system, the difference in hertz between the highest and lowest frequency component required for the accurate reproduction of the original signal.

BLACK LEVEL - The level of a picture signal corresponding to the maximum limit of black peaks. Refer to Figure 3.

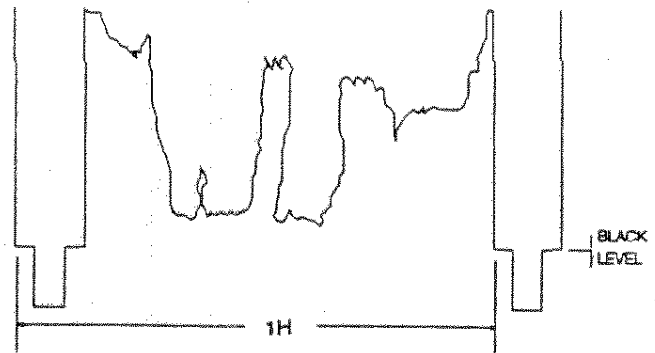

FIG. 3 BLACK LEVEL

BLANKING TIME - The length of time the electron beam of the CRT is turned off, i.e., the time from the leading edge of front porch to the trailing edge of back porch. Refer to Figure 4.

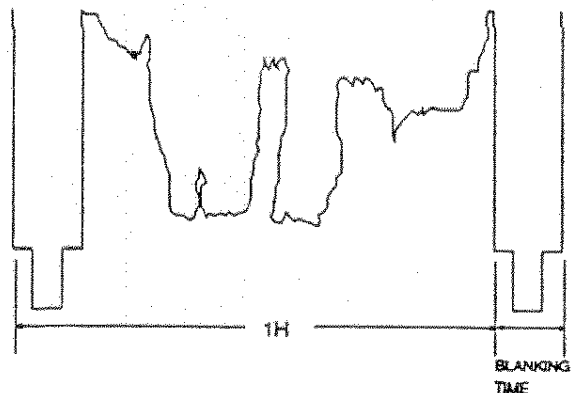

FIG. 4 HORIZONTAL BLANKING TIME.

BLOOMING - An increase in the size of the scanning spot on the CRT. Maybe caused by brightness set to high or high voltage problems.

BRIGHTNESS - The average or overall illumination of the picture area.

CHROMA - The color information within a video signal that consists of hue and saturation (amplitude). White, black and gray are monochrome (no color).

COLOR BURST (reference burst) - Used as a phase reference for the 3.579545MHz. oscillator. Refer to Figure 5.

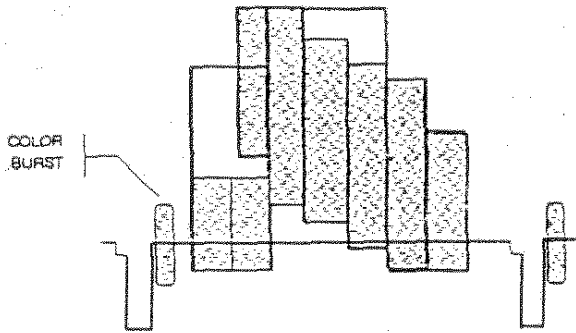

FIG. 5 COLOR BURST.

COMB FILTER - Provides outputs corresponding to each of its passbands and separates the chrominance and luminance.

COMPOSITE VIDEO - The complete video signal which includes, picture signal, blanking, sync signals, color sync signals and color information. Some computers and video cassette players have a composite video output and/or input. Refer to Figure 6.

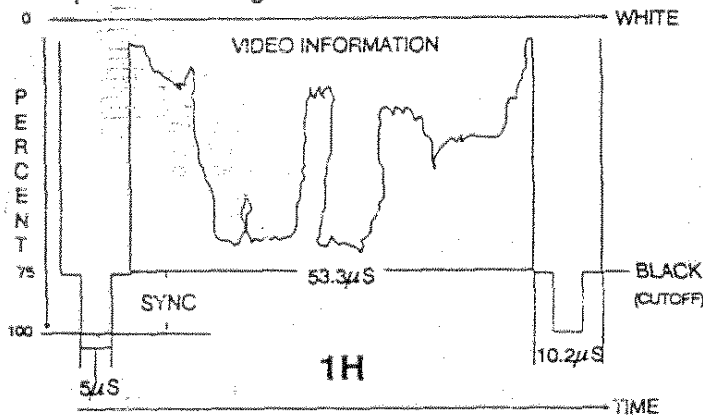

FIG. 6 COMPOSITE VIDEO (HORIZONTAL ONLY).

CONTRAST - This indicates the difference in density between the picture whites and the picture blacks.

CONTRAST RATIO - The maximum and minimum luminance values in a picture.

CONVERGENCE (REGISTRATION)- Proper alignment of the of the Red, Green, Blue, vertical and horizontal lines, as in video projection.

CRT-(Cathode Ray Tube)- A vacuum tube with an electron "gun" at one end and a fluorescent screen at the other.

DIGITAL VIDEO - Describes the output of some computers. TTL is a type of digital video output.

FIELD - $\frac{1}{2}$ of a television picture. One complete vertical scan of a picture. Present U.S. standard pictures are transmitted in two fields containing $262\frac{1}{2}$ lines each which are interlaced to produce 30 complete images (frames) per/second.

FRAME - This is the total area occupied by the picture. In the U.S. each frame contains two field a total of 525 horizontal scan lines and 30 complete frames per second.

FRAME RATE (vertical frequency) - The frequency at which frames are generated. Frame rates can vary from 45Hz to 120hz.

FOCAL LENGTH- Symbolized by f . The distance from the principal focus to the surface of a mirror or optical center of a lens. A shorter focal length provides a larger image size on the screen for a given projection distance.

FOOT LAMBERTS (f) - A unit of luminance equal to $1/\pi$ candle per square foot.

FRONT PORCH TIME - The time from the end of the horizontal scan line to the leading edge of the horizontal sync. pulse. Refer to Figure 7.

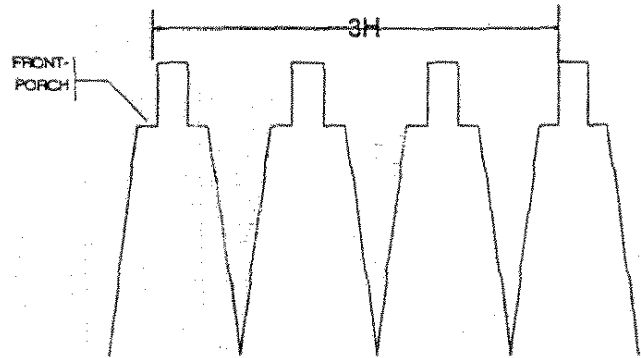

FIG. 7 FRONT PORCH TIME.

GAIN- The ability of a device to amplify a given signal. In the case of projection screens, the ability to amplify incident light.

GEOMETRY - The ability to reproduce the original scene without distortion. Refer to Figure 8.

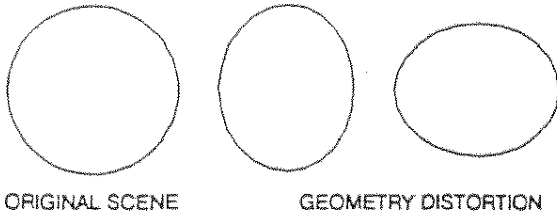

FIG. 8 GEOMETRY DISTORTION

HORIZONTAL SCAN RATE (*horizontal frequency*) - The number of horizontal scan lines per second. The US NTSC standard is **15,750 hertz**.

HORIZONTAL SWEEP - Movement of the scanning beam across the CRT.

HUE (*tint*) - That which distinguishes a color as red, yellow, blue etc..., difference between, white, black and gray are not considered hues.

INTERFACE - A device that translates (*converts*) an incoming video type into an RGB(S) video output.

INTERLACED SCANNING - A method of scanning whereby the *odd* and *even* numbered lines of a picture are sent out consecutively as two separate fields. A vertical offset between Field 1 and field 2 that causes lines of Field 1 to fall between the lines of Field 2.

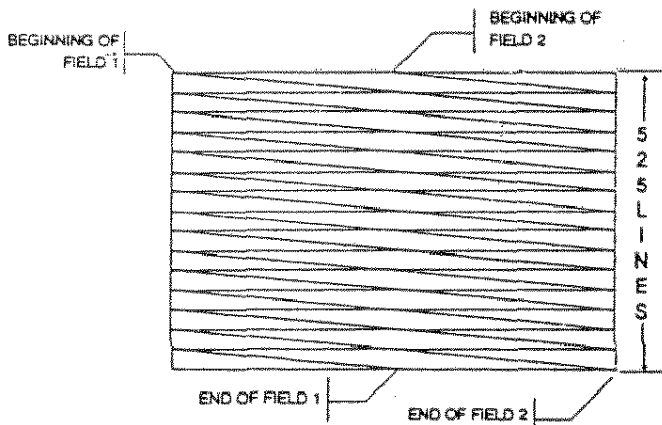

FIG. 9 INTERLACED SCANNING.

KEystone DISTORTION - A distortion in the horizontal or vertical direction in which the top is wider than at the bottom or vice versa, and the left side of the image is not equal in length to the right side of the image or vice versa.

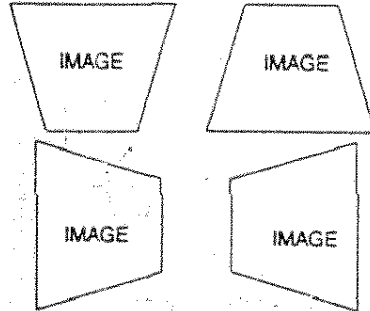

FIG. 10 KEystone DISTORTION.

LINEARITY- The ability to reproduce equal size squares through -out the entire projected image. Refer to Figure 11.

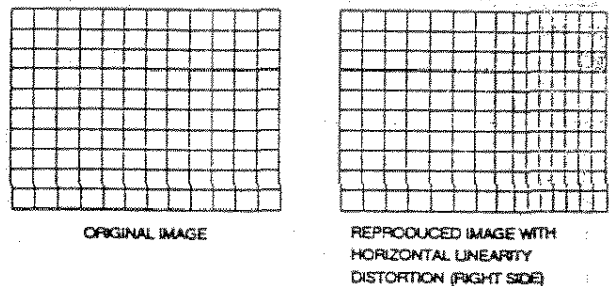

FIG. 11 LINEARITY DISTORTION (HORIZONTAL).

LINE TIME - The amount of time to produce a single trace (*scan line*) from left to right across the CRT.

LUMINANCE - The amount of light emitted by a light source, usually measured in foot-lamberts. In video luminance is considered the amplitude of the composite video signal. Refer to Figure 12.

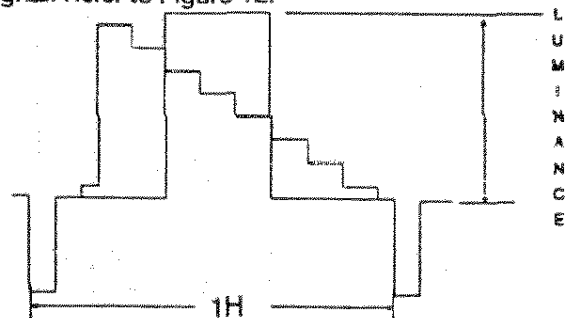

FIG. 12 LUMINANCE COMPONENT OF A STAIRSTEP PATTERN.

NTSC VIDEO (NTSC: National Television System Committee) - This is the standard video format used mainly in North America.

PAL VIDEO (Phase Alternation by Line) - A video format mainly used in Europe.

PINCUSHION - this distortion is noted when the four sides of the raster are curved inward (*concave*), leaving the corners extending outward (*convex*), or vice versa. Refer to Figure 13.

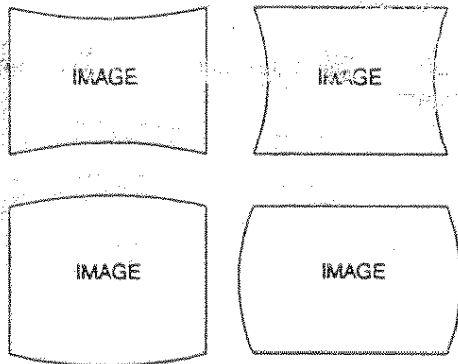

FIG. 13 PINCUSHION DISTORTION.

PIXEL (*picture element*) - A pixel is the smallest element of a picture. The greater the number of pixels the finer the image (*line*) on the screen, i.e., picture quality and resolution.

QUAD STANDARD DECODER - The ability of a device to accept and convert the NTSC, PAL, SECAM, and NTSC 4.43 video formats to RGB.

RASTER - The pattern generated by the horizontal and vertical deflection. Refer to Figure 14.

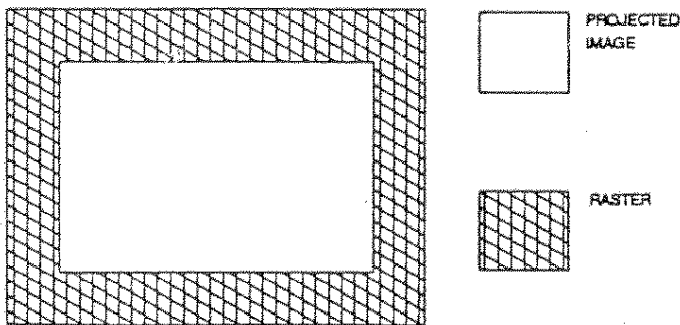

FIG. 14 RASTER VS. PICTURE AREA.

RESOLUTION - The maximum number of lines discernible on the screen within a distance equal to the picture height (width).

RETRACE TIME (*flyback time*) - This is the amount of time required for the electron beam to return from the end of a scanning line to the begin the next scan line. This retrace time is typically not seen due to blanking times. The blanking must be greater than or equal to the retrace time. Refer to Figure 15.

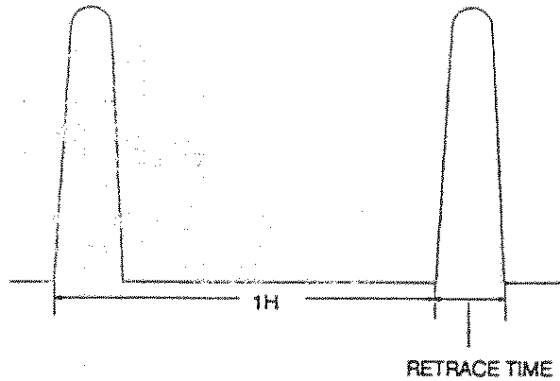

FIG. 15 RETRACE (FLYBACK) TIME.

RGB VIDEO - This refers to the output of computers and can be either *analog* or *digital*. Analog RGB can use 3,4 or 5 wire(s) and carry the signals such as red, green(sync) and blue (3 wire systems) or red, green, blue and composite sync (4 wire) or red, green, blue, horizontal drive (*sync.*) and vertical drive (*sync.*) (5 wire).

SCAN LINE - An active scan line equals (1/s) one horizontal line.

SECAM (Système Electronique Couleur Avec Memoire) - A video format mainly used in France.

SPOT SIZE - The diameter of the smallest dot that can be generated on the face of the CRT.

SYNC. - The signal employed to stabilize the image. Its composed of pulses at rates related to line and field frequencies. 1. In television it is part of the composite video signal. 2. In a computer it can be one of the following formats. (a) sync. on green (3 wire systems). (b) external composite sync, where the horizontal and vertical signals are combined (4 wire systems), or (c) separate horizontal and vertical drive signals (5 wire systems). Refer to Figure 16.

SYNC. WIDTH - The duration of each sync. pulse generated by the video source. This time is part of the blanking time. Refer to figure 16.

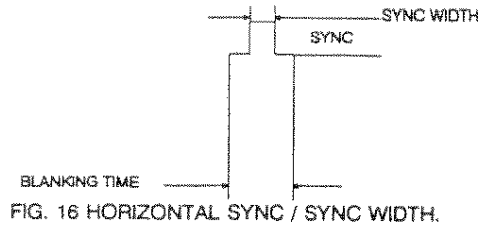

TERMINATED LINE - A transmission line that is terminated in a resistance (i.e.: 75 Ω) equal to the characteristics impedance of the line to avoid reflections.

TTL VIDEO - A video output of some computers which can give you a specific numbers of colors ie; 8,16 or 64. The TTL signal cannot utilize long cable. It is a form of RGB video.

VARIABLE SCAN - The ability to synchronize (lock) to inputs with different frequencies manually or automatically within a specified range.

VERTICAL BLANKING INTERVAL - That time at the beginning of each field of the video signal which blanks the picture while the CRT retrace returns to the top of the screen.

VERTICAL RETRACE - the return of the electron beam after each vertical sweep.

VERTICAL SWEEP - the downward or upward movement of the scanning beam.

